



EN

Air gouger

GT 600 SKK95

099-016099-EW501

Observe additional system documents!

12.08.2019

**Register now
and benefit!
Jetzt Registrieren
und Profitieren!**

www.ewm-group.com



General instructions

WARNING



Read the operating instructions!

The operating instructions provide an introduction to the safe use of the products.

- Read and observe the operating instructions for all system components, especially the safety instructions and warning notices!
- Observe the accident prevention regulations and any regional regulations!
- The operating instructions must be kept at the location where the machine is operated.
- Safety and warning labels on the machine indicate any possible risks. Keep these labels clean and legible at all times.
- The machine has been constructed to state-of-the-art standards in line with any applicable regulations and industrial standards. Only trained personnel may operate, service and repair the machine.
- Technical changes due to further development in machine technology may lead to a differing welding behaviour.

In the event of queries on installation, commissioning, operation or special conditions at the installation site, or on usage, please contact your sales partner or our customer service department on +49 2680 181-0.

A list of authorised sales partners can be found at www.ewm-group.com/en/specialist-dealers.

Liability relating to the operation of this equipment is restricted solely to the function of the equipment. No other form of liability, regardless of type, shall be accepted. This exclusion of liability shall be deemed accepted by the user on commissioning the equipment.

The manufacturer is unable to monitor whether or not these instructions or the conditions and methods are observed during installation, operation, usage and maintenance of the equipment.

An incorrectly performed installation can result in material damage and injure persons as a result. For this reason, we do not accept any responsibility or liability for losses, damages or costs arising from incorrect installation, improper operation or incorrect usage and maintenance or any actions connected to this in any way.

© EWM AG

Dr. Günter-Henle-Strasse 8
56271 Mündersbach Germany
Tel.: +49 2680 181-0, Fax: -244
Email: info@ewm-group.com
www.ewm-group.com

The copyright to this document remains the property of the manufacturer.

Copying, including extracts, only permitted with written approval.

The content of this document has been prepared and reviewed with all reasonable care. The information provided is subject to change; errors excepted.

1 Contents

1	Contents	3
2	For your safety	4
2.1	Notes on the use of these operating instructions	4
2.2	Explanation of icons	5
2.3	Part of the complete documentation	6
3	Intended use	7
3.1	General	7
3.2	Applications.....	7
3.2.1	MMA welding	7
3.2.2	Air arc gouging	7
3.3	Documents which also apply	8
3.3.1	Warranty	8
3.3.2	Declaration of Conformity.....	8
3.3.3	Service documents (spare parts)	8
4	Machine description – quick overview	9
4.1	GT 600 SKK95.....	9
5	Design and function	10
5.1	General	10
5.2	Transport and installation	11
5.2.1	Ambient conditions	11
5.2.1.1	In operation	11
5.2.1.2	Transport and storage.....	11
5.3	Connection.....	12
5.4	Operation	13
5.4.1	Insert carbon electrode.....	14
5.4.2	Air arc gouging	15
5.4.3	MMA welding	15
5.4.4	Replace slide valve O-ring	16
6	Maintenance, care and disposal	17
6.1	General	17
6.1.1	Cleaning	17
6.2	Maintenance work, intervals	17
6.2.1	Daily maintenance tasks.....	17
6.3	Disposing of equipment	18
7	Rectifying faults	19
7.1	Checklist for rectifying faults	19
8	Technical data	20
8.1	GT 600 SKK95.....	20
9	Spare and replacement parts	21
9.1	GT 600 SKK95.....	21
10	Appendix	23
10.1	Searching for a dealer.....	23

2 For your safety

2.1 Notes on the use of these operating instructions

DANGER

Working or operating procedures which must be closely observed to prevent imminent serious and even fatal injuries.

- Safety notes include the "DANGER" keyword in the heading with a general warning symbol.
- The hazard is also highlighted using a symbol on the edge of the page.

WARNING

Working or operating procedures which must be closely observed to prevent serious and even fatal injuries.

- Safety notes include the "WARNING" keyword in the heading with a general warning symbol.
- The hazard is also highlighted using a symbol in the page margin.

CAUTION

Working or operating procedures which must be closely observed to prevent possible minor personal injury.

- The safety information includes the "CAUTION" keyword in its heading with a general warning symbol.
- The risk is explained using a symbol on the edge of the page.



Technical aspects which the user must observe to avoid material or equipment damage.

Instructions and lists detailing step-by-step actions for given situations can be recognised via bullet points, e.g.:

- Insert the welding current lead socket into the relevant socket and lock.

2.2 Explanation of icons

Symbol	Description	Symbol	Description
	Indicates technical aspects which the user must observe.		Activate and release / Tap / Tip
	Switch off machine		Release
	Switch on machine		Press and hold
			Switch
	Incorrect / Invalid		Turn
	Correct / Valid		Numerical value – adjustable
	Input		Signal light lights up in green
	Navigation		Signal light flashes green
	Output		Signal light lights up in red
	Time representation (e.g.: wait 4 s / actuate)		Signal light flashes red
	Interruption in the menu display (other setting options possible)		
	Tool not required/do not use		
	Tool required/use		

2.3 Part of the complete documentation

These operating instructions are part of the complete documentation and valid only in combination with all other parts of these instructions! Read and observe the operating instructions for all system components, especially the safety instructions!

The illustration shows a general example of a welding system.

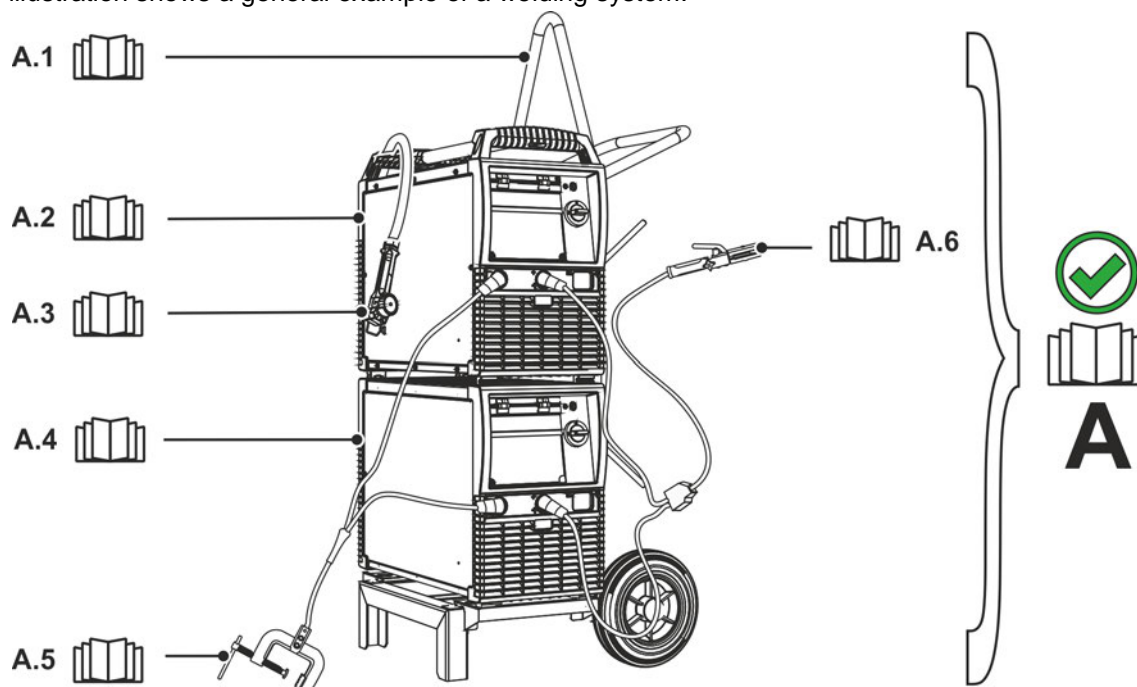

Figure 2-1

Item	Documentation
A.1	Transport cart
A.2	Power source
A.3	Remote control
A.4	Power source
A.5	Work clamp
A.6	Gouging torch
A	Complete documentation

3 Intended use

WARNING



Hazards due to improper usage!

The machine has been constructed to the state of the art and any regulations and standards applicable for use in industry and trade. It may only be used for the welding procedures indicated at the rating plate. Hazards may arise for persons, animals and material objects if the equipment is not used correctly. No liability is accepted for any damages arising from improper usage!

- The equipment must only be used in line with its designated purpose and by trained or expert personnel!
- Do not improperly modify or convert the equipment!

3.1 General

The ready-to-use air gouger consists of: hose package, handle, electrode holder and compressed air nozzle, including all necessary accessories and wearing parts.

Together the elements form a functioning unit that, if supplied with the necessary operating material, creates an arc and a compressed air jet for air arc gouging.

With air arc gouging, a carbon electrode creates a molten pool which is then blown off by the compressed air jet.

The slide valve at the air gouger is generally used to switch the compressed air jet on and off.

3.2 Applications

3.2.1 MMA welding

Manual arc welding or, for short, MMA welding. It is characterised by the fact that the arc burns between a melting electrode and the molten pool. There is no external protection; any protection against the atmosphere comes from the electrode.

3.2.2 Air arc gouging

During gouging, an arc burns between a carbon electrode and the workpiece, heating the workpiece until it is molten. At the same time, the molten metal is blown out with compressed air. Special electrode holders with a compressed-air connection and carbon electrodes are required for gouging.

3.3 Documents which also apply

3.3.1 Warranty

For more information refer to the "Warranty registration" brochure supplied and our information regarding warranty, maintenance and testing at www.ewm-group.com!

3.3.2 Declaration of Conformity

The labelled product complies with the following EC directives in terms of its design and construction:

-  • Low Voltage Directive (LVD)
• Electromagnetic Compatibility Directive (EMC)
• Restriction of Hazardous Substance (RoHS)

In case of unauthorised changes, improper repairs, non-compliance with specified deadlines for "Arc Welding Equipment – Inspection and Testing during Operation," and/or prohibited modifications which have not been explicitly authorised by the manufacturer, this declaration shall be voided. An original document of the specific declaration of conformity is included with every product.

3.3.3 Service documents (spare parts)

WARNING



Do not carry out any unauthorised repairs or modifications!

To avoid injury and equipment damage, the unit must only be repaired or modified by specialist, skilled persons!

The warranty becomes null and void in the event of unauthorised interference.

- Appoint only skilled persons for repair work (trained service personnel)!

Spare parts can be obtained from the relevant authorised dealer.

4 Machine description – quick overview

4.1 GT 600 SKK95

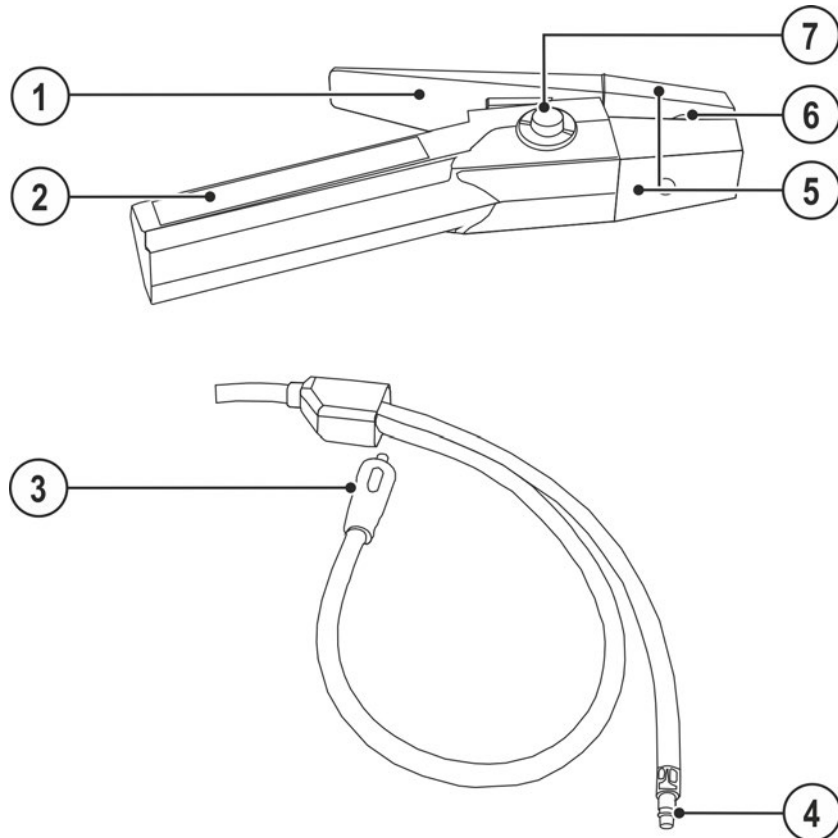

Figure 4-1

Item	Symbol	Description
1		Tension arm
2		Torch body
3		Welding current cable plug
4		Compressed air connection G 3/8"
5		Insulating jaws
6		Compressed air nozzle
7		Compressed air valve

5 Design and function

5.1 General

WARNING



Risk of injury from electrical voltage!

Contact with live parts, e.g. power connections, can be fatal!

- Observe the safety information on the first pages of the operating instructions!
- Commissioning must be carried out by persons who are specifically trained in handling power sources!
- Connect connection or power cables while the machine is switched off!

CAUTION



Risk of burning due to incorrect welding current connection!

If the welding current plugs (machine connections) are not locked or if the workpiece connection is contaminated (paint, corrosion), these connections and leads can heat up and cause burns when touched!

- Check welding current connections on a daily basis and lock by turning to the right when necessary.
- Clean workpiece connection thoroughly and secure properly. Do not use structural parts of the workpiece as welding current return lead!



Risk from electrical current!

If welding is carried out alternately using different methods and if a welding torch and an electrode holder remain connected to the machine, the open-circuit/welding voltage is applied simultaneously on all cables.

- The torch and the electrode holder should therefore always be placed on an insulated surface before starting work and during breaks.



Accessory components and the power source itself can be damaged by incorrect connection!

- **Only insert and lock accessory components into the relevant connection socket when the machine is switched off.**
- **Comprehensive descriptions can be found in the operating instructions for the relevant accessory components.**
- **Accessory components are detected automatically after the power source is switched on.**



Protective dust caps protect the connection sockets and therefore the machine against dirt and damage.

- **The protective dust cap must be fitted if there is no accessory component being operated on that connection.**
- **The cap must be replaced if faulty or if lost!**

Read and observe the documentation to all system and accessory components!

5.2 Transport and installation

CAUTION



Risk of accidents due to supply lines!

During transport, attached supply lines (mains leads, control cables, etc.) can cause risks, e.g. by causing connected machines to tip over and injure persons!

- Disconnect all supply lines before transport!

5.2.1 Ambient conditions



Equipment damage due to contamination!

Unusually high amounts of dust, acids, corrosive gases or substances can damage the machine (observe maintenance intervals > see 6.2 chapter).

- **Avoid large amounts of smoke, steam, oily fumes, grinding dust and corrosive ambient air!**

5.2.1.1 In operation

Temperature range of the ambient air:

- -10 °C to +40 °C (-13 F to 104 F)^[1]

Relative humidity:

- up to 50 % at 40 °C (104 F)
- up to 90 % at 20 °C (68 F)

5.2.1.2 Transport and storage

Storage in a closed area, temperature range of the ambient air:

- -25 °C to +55 °C (-13 F to 131 F)^[1]

Relative humidity

- up to 90 % at 20 °C (68 F)

^[1] Ambient temperature dependent on coolant! Observe the coolant temperature range of the torch cooling

5.3 Connection

⚠ WARNING



Hazard when interconnecting multiple power sources!

If a number of power sources are to be connected in parallel or in series, only a technical specialist may interconnect the sources as per standard IEC 60974-9:2010: Installation and use and German Accident Prevention Regulation BVG D1 (formerly VBG 15) or country-specific regulations.

Before commencing arc welding, a test must verify that the equipment cannot exceed the maximum permitted open circuit voltage.

- Only qualified personnel may connect the machine.
- When taking individual power sources out of operation, all mains and welding current leads must be safely disconnected from the welding system as a whole. (Hazard due to reverse polarity voltage!)
- Do not interconnect welding machines with pole reversing switch (PWS series) or machines for AC welding since a minor error in operation can cause the welding voltages to be combined, which is not permitted.

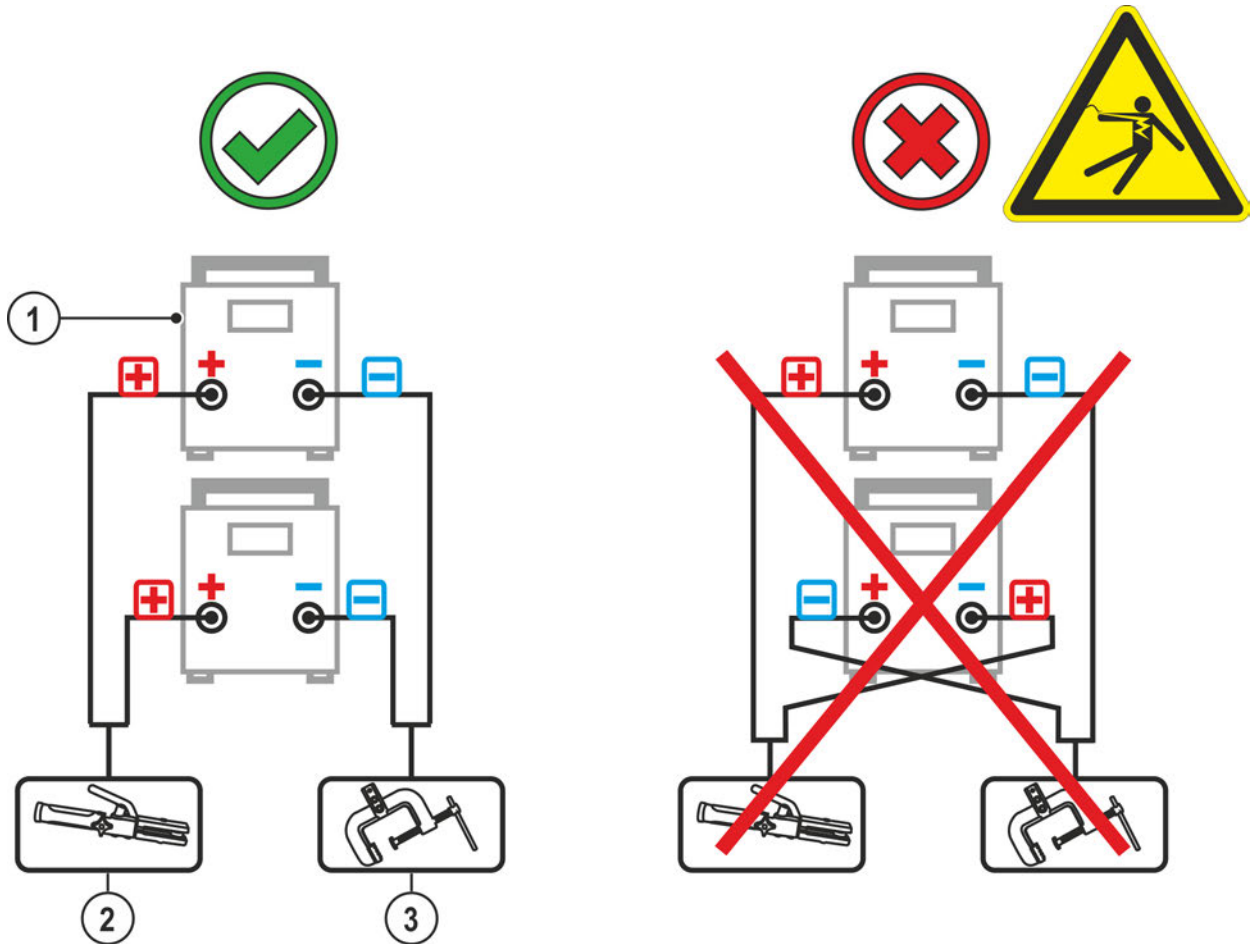

Figure 5-1

Item	Symbol	Description
1		Power source
2		Gouging torch
3		Workpiece lead

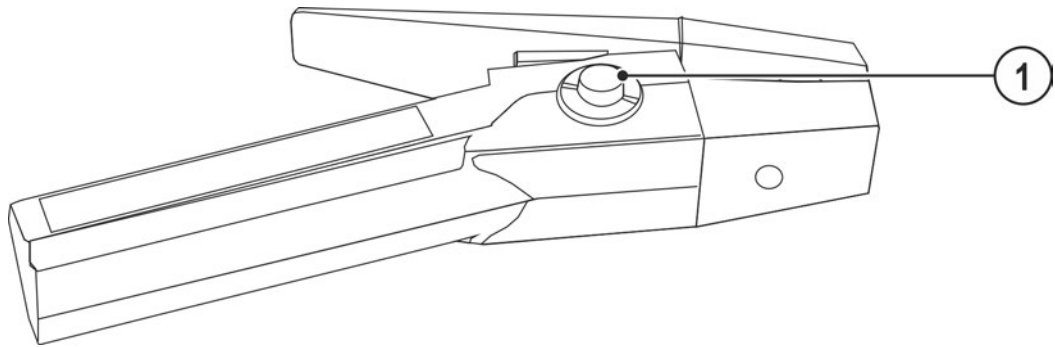

Figure 5-2

Item	Symbol	Description
1		Compressed air valve

- Keep the slide valve at the handle locked before connecting.

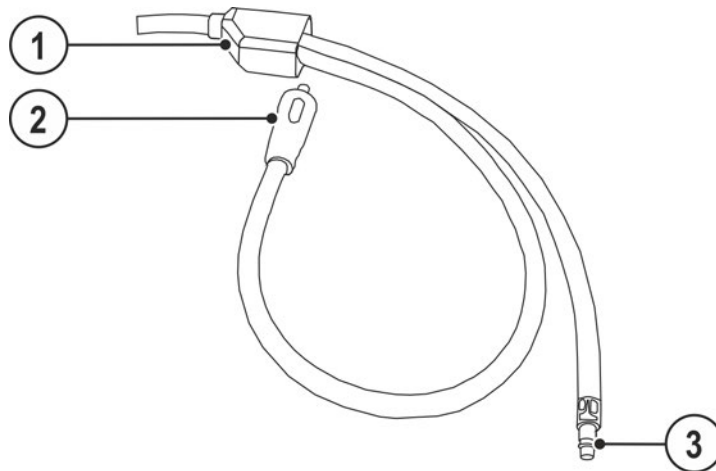

Figure 5-3

Item	Symbol	Description
1		Protective dust cap
2		Welding current cable plug
3		Compressed air connection G 3/8"

- Plug the welding current cable plug into the welding current connection of the welding machine and lock.
- Attach compressed air hose to compressed air connection 3/8" with clamping clip.
- Pull protective dust cap through connections.

Polarity depends on the instructions from the electrode manufacturer given on the electrode packaging.

Observe the maximum pressure > see 8 chapter!

5.4 Operation

WARNING



Risk of injury due to hot metal or slag sparks!

Contact with hot metal or slag sparks results in burns! Flying sparks can reach a distance of up to 10 m! Flammable and explosive substances can catch fire!

- When carrying out air arc gouging tasks, wear a leather apron and a flame retardant welder coverall!
- Install suitable screening to reduce the area affected by flying sparks!
- Remove flammable and explosive substances from the danger zone!

5.4.1 Insert carbon electrode

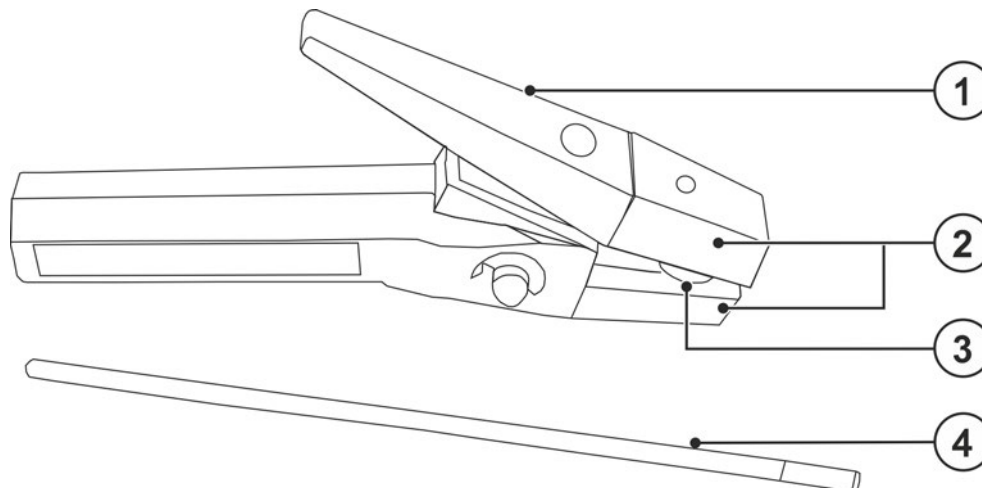

Figure 5-4

Item	Symbol	Description
1		Tension arm
2		Insulating jaws
3		Compressed air nozzle
4		Carbon electrode

- Hold down the electrode holder.
- Insert carbon electrode and clamp tight with the insulating jaws.
- For air arc gouging, insert only half the length of the electrode into the holder to ensure an even compressed air jet.

5.4.2 Air arc gouging

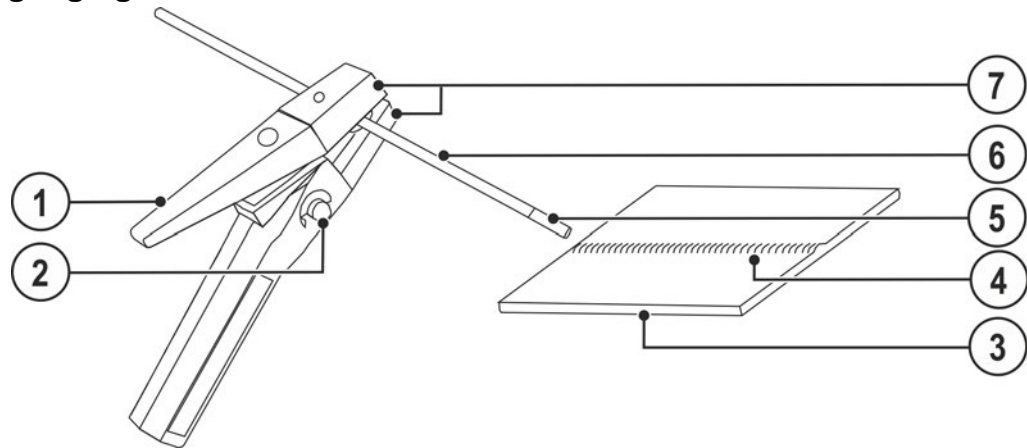

Figure 5-5

Item	Symbol	Description
1		Tension arm
2		Compressed air valve
3		Work piece
4		Weld seam
5		Carbon tip
6		Carbon electrode
7		Insulating jaws

- Open the compressed air valve.
- Ignite arc by shortly touching the carbon electrode against the workpiece and then withdraw the carbon electrode a bit.
- Keep the arc very short and guide the carbon electrode evenly over the workpiece.
- The subsequent compressed air jet blows off the fused material.

5.4.3 MMA welding

- For MMA welding, disconnect the compressed air supply from the air gouger and keep the compressed air valve locked.

5.4.4 Replace slide valve O-ring

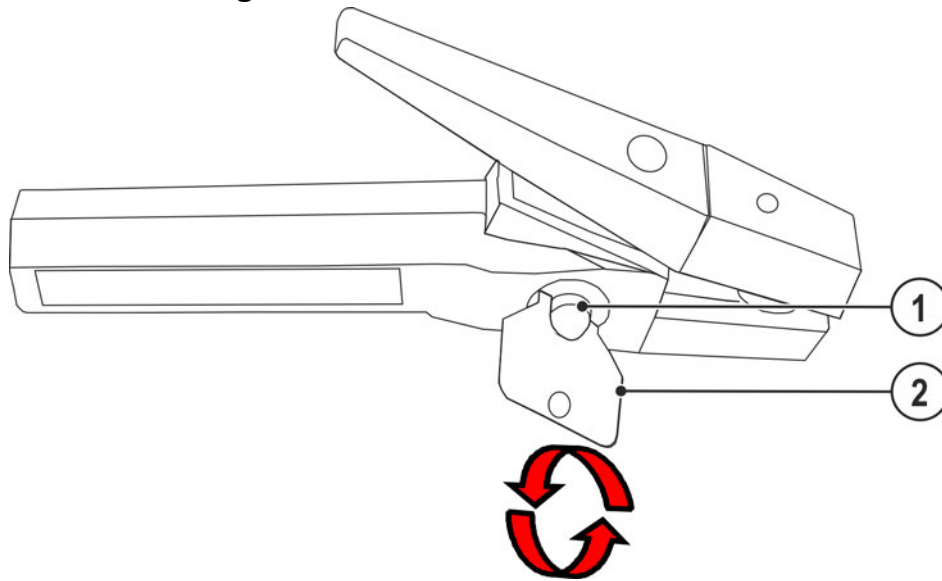

Figure 5-6

Item	Symbol	Description
1		Cut-off valve Control of compressed air supply
2		Key to open the slide valve

- Open the slide valve with the provided key.

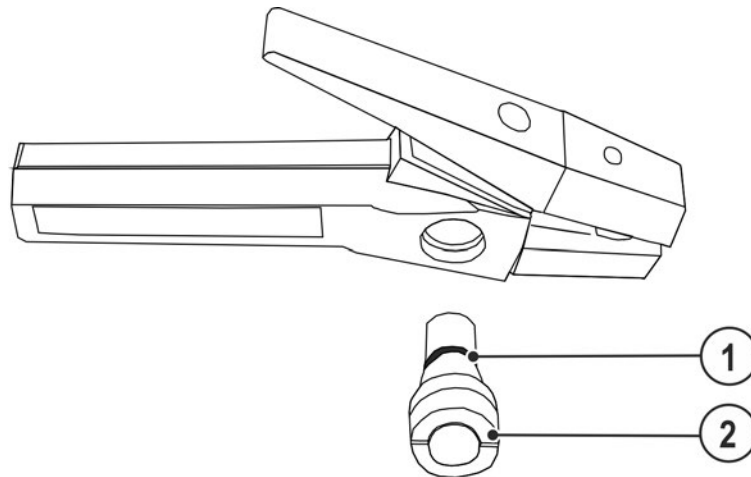

Figure 5-7

Item	Symbol	Description
1		O-ring
2		Cut-off valve Control of compressed air supply

- Replace O-ring, reinsert slide valve and tighten with the key.

6 Maintenance, care and disposal

6.1 General

DANGER



Risk of injury due to electrical voltage after switching off!
Working on an open machine can lead to fatal injuries!
Capacitors are loaded with electrical voltage during operation. Voltage remains present for up to four minutes after the mains plug is removed.

1. Switch off machine.
2. Remove the mains plug.
3. Wait for at least 4 minutes until the capacitors have discharged!

WARNING



Incorrect maintenance, testing and repair!
Maintenance, testing and repair of the machine may only be carried out by skilled and qualified personnel. A qualified person is one who, because of his or her training, knowledge and experience, is able to recognise the dangers that can occur while testing welding power sources as well as possible subsequent damage, and who is able to implement the required safety procedures.

Observe the maintenance instructions > see 6.2 chapter.

- In the event that the provisions of one of the below-stated tests are not met, the machine must not be operated again until it has been repaired and a new test has been carried out!

Repair and maintenance work may only be performed by qualified authorised personnel; otherwise the right to claim under warranty is void. In all service matters, always consult the dealer who supplied the machine. Return deliveries of defective equipment subject to warranty may only be made through your dealer. When replacing parts, use only original spare parts. When ordering spare parts, please quote the machine type, serial number and item number of the machine, as well as the type designation and item number of the spare part.

Under the specified ambient conditions and normal working conditions this machine is essentially maintenance-free and requires just a minimum of care.

Contamination of the machine may impair service life and duty cycle. The cleaning intervals depend on the ambient conditions and the resulting contamination of the machine. The minimum interval is every six months.

6.1.1 Cleaning

- Clean the outer surfaces with a moist cloth (no aggressive cleaning agents).
- Purge the machine venting channel and cooling fins (if present) with oil- and water-free compressed air. Compressed air may overspeed and destroy the machine fans. Never direct the compressed air directly at the machine fans. Mechanically block the fans, if required.
- Check the coolant for contaminants and replace, if necessary.

6.2 Maintenance work, intervals

6.2.1 Daily maintenance tasks

- Check that all connections and wearing parts are hand-tight and tighten if necessary.
- Check hose package and power connections for exterior damage and replace or have repaired by specialist staff as necessary!
- Check that all screw and plug connections and replaceable parts are secured correctly, tighten if necessary.
- Remove any spatter.

6.3 Disposing of equipment



Proper disposal!

The machine contains valuable raw materials, which should be recycled, and electronic components, which must be disposed of.

- **Do not dispose of in household waste!**
- **Observe the local regulations regarding disposal!**
- According to European provisions (Directive 2012/19/EU on Waste of Electrical and Electronic Equipment), used electric and electronic equipment may no longer be placed in unsorted municipal waste. It must be collected separately. The symbol depicting a waste container on wheels indicates that the equipment must be collected separately.
This machine has to be disposed of, or recycled, in accordance with the waste separation systems in use.
- According to German law (law governing the distribution, taking back and environmentally correct disposal of electric and electronic equipment (ElektroG)), used machines are to be placed in a collection system separate from unsorted municipal waste. The public waste management utilities (communities) have created collection points at which used equipment from private households can be disposed of free of charge.
- Information about returning used equipment or about collections can be obtained from the respective municipal administration office.
- In addition to this, returns are also possible throughout Europe via EWM sales partners.

7 Rectifying faults

All products are subject to rigorous production checks and final checks. If, despite this, something fails to work at any time, please check the product using the following flowchart. If none of the fault rectification procedures described leads to the correct functioning of the product, please inform your authorised dealer.

7.1 Checklist for rectifying faults

The correct machine equipment for the material and process gas in use is a fundamental requirement for perfect operation!

Legend	Symbol	Description
	↘	Fault/Cause
	✘	Remedy

Air gouger overheating

- ↘ Loose welding current connections
 - ✘ Tighten power connections on the torch and/or on the workpiece
- ↘ Overload
 - ✘ Check and correct welding current setting
- ↘ Low air pressure volume
 - ✘ Fully open valve
 - ✘ Check compressed air supply
- ↘ Carbon electrode too short
 - ✘ Correct clamping length
 - ✘ Replace carbon electrode

Unstable arc

- ↘ Unsuitable or worn equipment
 - ✘ Check and replace if necessary
- ↘ Incompatible parameter settings
 - ✘ Check settings and correct if necessary

8 Technical data

Performance specifications and guarantee only in connection with original spare and replacement parts!

8.1 GT 600 SKK95

Electrode	Carbon electrode, round or flat
Round carbon electrode diameter	3 - 10 mm
Flat carbon electrode width	10 / 16 mm
Flat carbon electrode thickness	5 mm
Voltage type	AC or DC
Electrode polarity	DC positive for cast steel and steel alloys DC negative for nonferrous metal, manganese high carbon steel and grey cast iron AC for grey cast iron, aluminium and nickel alloys
Cooling type	compressed air
Guide type	Manually operated
Open-circuit/ignition voltage	approx. 60 V
Duty cycle	≥ 60 %
Maximum welding current	600 A
Ambient temperature	-10 °C to +40 °C
Protection classification for the machine connections (EN 60529)	IP3X
Hose package length	3.0 m
Nom. compressed air	7 bar
Compressed air connection	3/8"-18 NPT
Nom. flow rate	approx. 0.60 m ³ /min
Safety marking	CE
Applied harmonised standards	See declaration of conformity (appliance documents)

9 Spare and replacement parts

9.1 GT 600 SKK95

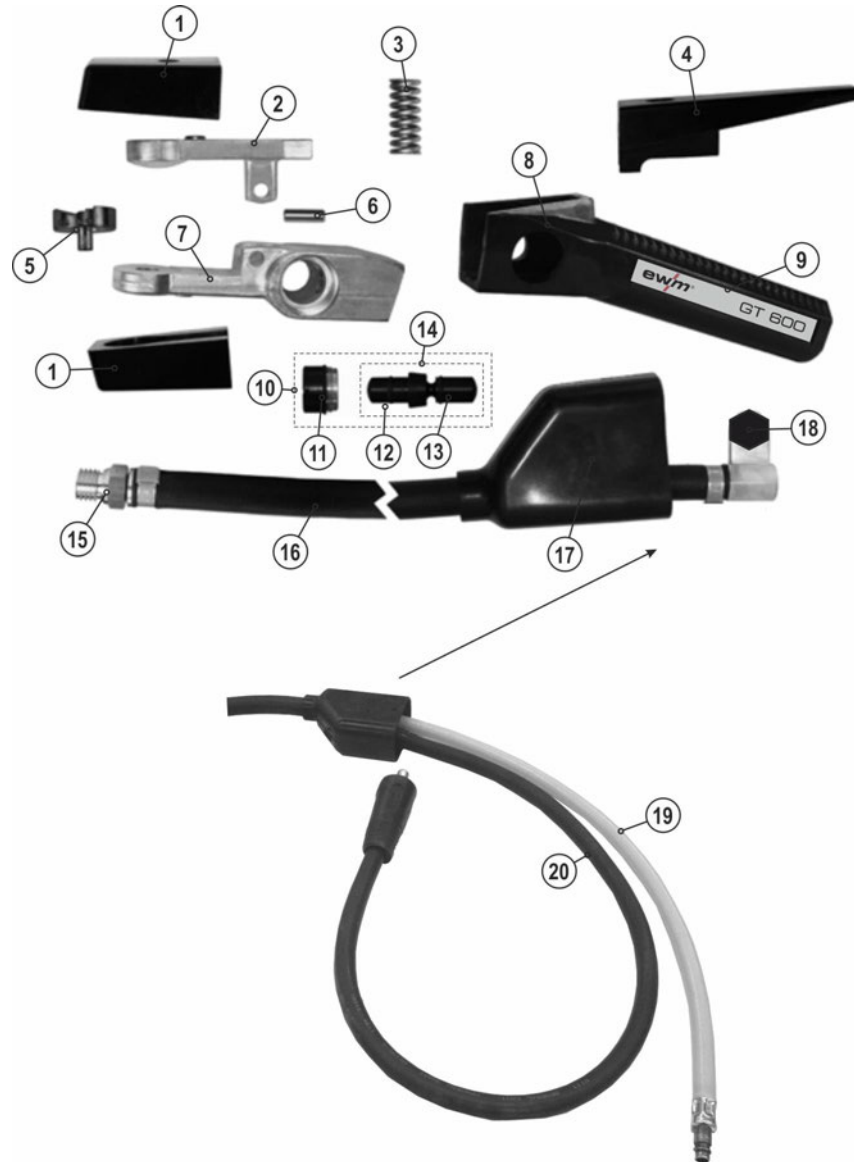

Figure 9-1

Item	Quantity	Description	Item number
1	1	Insulating set (IS GT600)	094-016201-00000
2	1	Lever top (HO GT600)	094-016202-00000
3	1	Pressure spring (DF GT600)	094-016206-00000
4	1	Lever (H GT600)	094-016203-00000
5	1	Flat socket (GT 600)	094-016215-00000
6	1	Lever bolt (HB GT600)	094-016205-00000
7	1	Torch body (BK GT600)	094-016204-00000
8	1	Handle mould	094-016214-00000
9	1	Adhesive film (KLF-EWM GT600)	094-016163-00000
10	1	Valve, complete	094-016211-00000
11	1	Mounting nut	094-016210-00000
12	1	O-ring	094-016209-00000
13	1	Slider (S GT600)	094-016207-00000
14	1	Slider with O-ring	094-016208-00000
15	1	Connecting piece	094-016213-00000
16	1	Hose package (SP GT600)	094-016818-00000
17	1	Insulating joint	094-016212-00000
18	1	Hexagonal screw (M10x20/DIN933/8.8/galvanised)	064-000603-00000
18	1	Plain washer	064-000681-00000
18	1	Hexagonal nut	064-000574-00000
19	1	Compressed air hose (compressed air / 650mm for gouging torch)	092-003619-00000
20	1	Power cable (95QMM/H01-N2-D/1000mm)	092-003618-00000

10 Appendix

10.1 Searching for a dealer

Sales & service partners
www.ewm-group.com/en/specialist-dealers



"More than 400 EWM sales partners worldwide"