



EN

Power source

Titan XQ 350 puls D
Titan XQ 400 puls D
Titan XQ 500 puls D
Titan XQ 600 puls D

099-005560-EW501

Observe additional system documents!

20.11.2020

**Register now
and benefit!
Jetzt Registrieren
und Profitieren!**

www.ewm-group.com



General instructions

WARNING



Read the operating instructions!

The operating instructions provide an introduction to the safe use of the products.

- Read and observe the operating instructions for all system components, especially the safety instructions and warning notices!
- Observe the accident prevention regulations and any regional regulations!
- The operating instructions must be kept at the location where the machine is operated.
- Safety and warning labels on the machine indicate any possible risks. Keep these labels clean and legible at all times.
- The machine has been constructed to state-of-the-art standards in line with any applicable regulations and industrial standards. Only trained personnel may operate, service and repair the machine.
- Technical changes due to further development in machine technology may lead to a differing welding behaviour.

In the event of queries on installation, commissioning, operation or special conditions at the installation site, or on usage, please contact your sales partner or our customer service department on +49 2680 181-0.

A list of authorised sales partners can be found at www.ewm-group.com/en/specialist-dealers.

Liability relating to the operation of this equipment is restricted solely to the function of the equipment. No other form of liability, regardless of type, shall be accepted. This exclusion of liability shall be deemed accepted by the user on commissioning the equipment.

The manufacturer is unable to monitor whether or not these instructions or the conditions and methods are observed during installation, operation, usage and maintenance of the equipment.

An incorrectly performed installation can result in material damage and injure persons as a result. For this reason, we do not accept any responsibility or liability for losses, damages or costs arising from incorrect installation, improper operation or incorrect usage and maintenance or any actions connected to this in any way.

© EWM AG

Dr. Günter-Henle-Strasse 8
56271 Mündersbach Germany
Tel.: +49 2680 181-0, Fax: -244
Email: info@ewm-group.com
www.ewm-group.com

The copyright to this document remains the property of the manufacturer.

Copying, including extracts, only permitted with written approval.

The content of this document has been prepared and reviewed with all reasonable care. The information provided is subject to change; errors excepted.

1 Contents

1	Contents	3
2	For your safety	5
2.1	Notes on using these operating instructions.....	5
2.2	Explanation of icons.....	6
2.3	Safety instructions.....	7
2.4	Transport and installation	10
3	Intended use	12
3.1	Use and operation solely with the following machines	12
3.2	Applications.....	12
3.3	Documents which also apply	12
3.3.1	Warranty	12
3.3.2	Declaration of Conformity.....	13
3.3.3	Welding in environments with increased electrical hazards.....	13
3.3.4	Service documents (spare parts and circuit diagrams).....	13
3.3.5	Calibration/Validation	13
3.3.6	Part of the complete documentation.....	14
4	Machine description – quick overview	15
4.1	Machine configuration.....	15
4.2	Front view / side view from the right	16
4.3	Rear view / side view from left	18
5	Design and function	20
5.1	Transport and installation	20
5.1.1	Lifting by crane	20
5.1.1.1	Craning principle	20
5.1.2	Ambient conditions	21
5.1.2.1	In operation	21
5.1.2.2	Transport and storage.....	21
5.1.3	Machine cooling.....	21
5.1.4	Workpiece lead, general.....	21
5.1.5	Welding torch cooling system.....	22
5.1.5.1	Functional characteristics	22
5.1.5.2	Permitted torch coolant	22
5.1.5.3	Maximal hose package length	22
5.1.5.4	Adding coolant	23
5.1.6	Notes on the installation of welding current leads.....	24
5.1.7	Stray welding currents.....	25
5.1.8	Connecting the intermediate hose package to the power source	26
5.1.8.1	Intermediate hose package strain relief.....	27
5.1.8.2	Possible attachment points	27
5.1.8.3	Locking the strain relief	28
5.1.9	Shielding gas supply (shielding gas cylinder for welding machine)	28
5.1.9.1	Pressure regulator connection	28
5.1.10	Mains connection.....	29
5.1.10.1	Visual inspection of the set mains voltage.....	29
5.1.10.2	Adjusting the power source to the mains voltage	30
5.1.10.3	Re-commissioning.....	30
5.1.10.4	Mains configuration.....	31
5.1.11	Switching on and system diagnosis	31
5.1.11.1	LED status bar - display of operating status	31
5.1.12	Protective flap, welding machine control.....	32
5.2	MIG/MAG welding.....	33
5.2.1	Connection for workpiece lead	33
5.2.2	Welding task selection.....	33
5.2.3	Setting the shielding gas volume (gas test)/rinse hose package	34
5.3	TIG welding.....	34
5.3.1	Connection for workpiece lead	34
5.3.2	Welding task selection.....	35
5.4	MMA welding	35

5.4.1	Connecting the electrode holder and workpiece lead	35
5.4.2	Welding task selection	35
5.5	Remote control	35
5.6	Interfaces for automation	36
5.6.1	Automation interface	36
5.6.2	RINT X12 robot interface	37
5.6.3	BUSINT X11 industrial bus interface	37
5.7	PC interface	37
5.7.1	Connection	37
5.8	Component identification	37
5.9	Network connection	38
6	Maintenance, care and disposal	39
6.1	General	39
6.2	Explanation of icons	40
6.3	Maintenance schedule	41
6.3.1	Dirt filter	42
6.3.2	Coolant error	43
6.3.3	Heat exchanger (torch cooling)	45
6.3.4	Power source (inverter)	46
6.3.5	Annual test (inspection and testing during operation)	47
6.4	Disposing of equipment	47
7	Rectifying faults	48
7.1	Error messages (power source)	48
7.2	Warnings	51
7.3	Checklist for rectifying faults	52
7.4	Vent coolant circuit	53
7.5	Fixing the pump shaft (coolant circuit)	54
8	Technical data	55
8.1	Dimensions and weights	55
8.2	Welding torch cooling system	56
8.3	Performance data	57
8.3.1	Titan XQ 350 puls D	57
8.3.2	Titan XQ 400 puls D	58
8.3.3	Titan XQ 500 puls D	59
8.3.4	Titan XQ 600 puls D	60
9	Accessories	61
9.1	General accessories	61
9.2	7-pole remote control	61
9.2.1	Extension cable	61
9.3	19-pole remote control	61
9.3.1	Connection cables	61
9.3.2	Extension cable	61
9.4	Options	62
9.5	Computer communication	62
9.6	Welding torch cooling system	62
9.6.1	Coolant - type blueCool	62
9.6.2	Coolant - type KF	62
10	Appendix	63
10.1	Searching for a dealer	63

2 For your safety

2.1 Notes on using these operating instructions

DANGER

Working or operating procedures which must be closely observed to prevent imminent serious and even fatal injuries.

- Safety notes include the "DANGER" keyword in the heading with a general warning symbol.
- The hazard is also highlighted using a symbol on the edge of the page.

WARNING

Working or operating procedures which must be closely observed to prevent serious and even fatal injuries.

- Safety notes include the "WARNING" keyword in the heading with a general warning symbol.
- The hazard is also highlighted using a symbol in the page margin.

CAUTION

Working or operating procedures which must be closely observed to prevent possible minor personal injury.

- The safety information includes the "CAUTION" keyword in its heading with a general warning symbol.
- The risk is explained using a symbol on the edge of the page.



Technical aspects which the user must observe to avoid material or equipment damage.

Instructions and lists detailing step-by-step actions for given situations can be recognised via bullet points, e.g.:

- Insert the welding current lead socket into the relevant socket and lock.

2.2 Explanation of icons

Symbol	Description	Symbol	Description
	Indicates technical aspects which the user must observe.		Activate and release / Tap / Tip
	Switch off machine		Release
	Switch on machine		Press and hold
			Switch
	Incorrect / Invalid		Turn
	Correct / Valid		Numerical value – adjustable
	Input		Signal light lights up in green
	Navigation		Signal light flashes green
	Output		Signal light lights up in red
	Time representation (e.g.: wait 4 s / actuate)		Signal light flashes red
	Interruption in the menu display (other setting options possible)		
	Tool not required/do not use		
	Tool required/use		

2.3 Safety instructions

WARNING



**Risk of accidents due to non-compliance with the safety instructions!
Non-compliance with the safety instructions can be fatal!**

- Carefully read the safety instructions in this manual!
- Observe the accident prevention regulations and any regional regulations!
- Inform persons in the working area that they must comply with the regulations!



Risk of injury from electrical voltage!

Voltages can cause potentially fatal electric shocks and burns on contact. Even low voltages can cause a shock and lead to accidents.

- Never touch live components such as welding current sockets or stick, tungsten or wire electrodes!
- Always place torches and electrode holders on an insulated surface!
- Wear the full personal protective equipment (depending on the application)!
- The machine may only be opened by qualified personnel!
- The device must not be used to defrost pipes!



Hazard when interconnecting multiple power sources!

If a number of power sources are to be connected in parallel or in series, only a technical specialist may interconnect the sources as per standard IEC 60974-9:2010: Installation and use and German Accident Prevention Regulation BVG D1 (formerly VBG 15) or country-specific regulations.

Before commencing arc welding, a test must verify that the equipment cannot exceed the maximum permitted open circuit voltage.

- Only qualified personnel may connect the machine.
- When taking individual power sources out of operation, all mains and welding current leads must be safely disconnected from the welding system as a whole. (Hazard due to reverse polarity voltage!)
- Do not interconnect welding machines with pole reversing switch (PWS series) or machines for AC welding since a minor error in operation can cause the welding voltages to be combined, which is not permitted.



Risk of injury due to improper clothing!

During arc welding, radiation, heat and voltage are sources of risk that cannot be avoided. The user has to be equipped with the complete personal protective equipment at all times. The protective equipment has to include:

- Respiratory protection against hazardous substances and mixtures (fumes and vapours); otherwise implement suitable measures such as extraction facilities.
- Welding helmet with proper protection against ionizing radiation (IR and UV radiation) and heat.
- Dry welding clothing (shoes, gloves and body protection) to protect against warm environments with conditions comparable to ambient temperatures of 100 °C or higher and arcing and work on live components.
- Hearing protection against harming noise.

WARNING



Risk of injury due to radiation or heat!

Arc radiation can lead to skin and eye injuries.

Contact with hot workpieces and sparks can lead to burns.

- Use hand shield or welding helmet with the appropriate safety level (depends on the application).
- Wear dry protective clothing (e.g. hand shield, gloves, etc.) in accordance with the applicable regulations of your country.
- Persons who are not directly involved should be protected with a welding curtain or suitable safety screen against radiation and the risk of blinding!



Explosion risk!

Apparently harmless substances in closed containers may generate excessive pressure when heated.

- Move containers with inflammable or explosive liquids away from the working area!
- Never heat explosive liquids, dusts or gases by welding or cutting!



Fire hazard!

Due to the high temperatures, sparks, glowing parts and hot slag that occur during welding, there is a risk of flames.

- Be watchful of potential sources of fire in the working area!
- Do not carry any easily inflammable objects, e.g. matches or lighters.
- Ensure suitable fire extinguishers are available in the working area!
- Thoroughly remove any residue of flammable materials from the workpiece prior to starting to weld.
- Only further process workpieces after they have cooled down. Do not allow them to contact any flammable materials!

⚠ CAUTION**Smoke and gases!**

Smoke and gases can lead to breathing difficulties and poisoning. In addition, solvent vapour (chlorinated hydrocarbon) may be converted into poisonous phosgene due to the ultraviolet radiation of the arc!

- Ensure that there is sufficient fresh air!
- Keep solvent vapour away from the arc beam field!
- Wear suitable breathing apparatus if appropriate!

**Noise exposure!**

Noise exceeding 70 dBA can cause permanent hearing damage!

- Wear suitable ear protection!
- Persons located within the working area must wear suitable ear protection!



According to IEC 60974-10, welding machines are divided into two classes of electromagnetic compatibility (the EMC class can be found in the Technical data) > see 8 chapter:



Class A machines are not intended for use in residential areas where the power supply comes from the low-voltage public mains network. When ensuring the electromagnetic compatibility of class A machines, difficulties can arise in these areas due to interference not only in the supply lines but also in the form of radiated interference.



Class B machines fulfil the EMC requirements in industrial as well as residential areas, including residential areas connected to the low-voltage public mains network.

Setting up and operating

When operating arc welding systems, in some cases, electro-magnetic interference can occur although all of the welding machines comply with the emission limits specified in the standard. The user is responsible for any interference caused by welding.

In order to **evaluate** any possible problems with electromagnetic compatibility in the surrounding area, the user must consider the following: (see also EN 60974-10 Appendix A)

- Mains, control, signal and telecommunication lines
- Radios and televisions
- Computers and other control systems
- Safety equipment
- The health of neighbouring persons, especially if they have a pacemaker or wear a hearing aid
- Calibration and measuring equipment
- The immunity to interference of other equipment in the surrounding area
- The time of day at which the welding work must be carried out

Recommendations for reducing interference emission

- Mains connection, e.g. additional mains filter or shielding with a metal tube
- Maintenance of the arc welding system
- Welding leads should be as short as possible and run closely together along the ground
- Potential equalization
- Earthing of the workpiece. In cases where it is not possible to earth the workpiece directly, it should be connected by means of suitable capacitors.
- Shielding from other equipment in the surrounding area or the entire welding system

**Electromagnetic fields!**

The power source may cause electrical or electromagnetic fields to be produced which could affect the correct functioning of electronic equipment such as IT or CNC devices, telecommunication lines, power cables, signal lines and pacemakers.



- Observe the maintenance instructions > see 6.3 chapter!
- Unwind welding leads completely!
- Shield devices or equipment sensitive to radiation accordingly!
- The correct functioning of pacemakers may be affected (obtain advice from a doctor if necessary).

CAUTION



Obligations of the operator!

The respective national directives and laws must be complied with when operating the machine!

- Implementation of national legislation relating to framework directive 89/391/EEC on the introduction of measures to encourage improvements in the safety and health of workers at work and associated individual guidelines.
- In particular, directive 89/655/EEC concerning the minimum safety and health requirements for the use of work equipment by workers at work.
- The regulations applicable to occupational safety and accident prevention in the country concerned.
- Setting up and operating the machine as per IEC 60974.-9.
- Brief the user on safety-conscious work practices on a regular basis.
- Regularly inspect the machine as per IEC 60974.-4.



The manufacturer's warranty becomes void if non-genuine parts are used!

- ***Only use system components and options (power sources, welding torches, electrode holders, remote controls, spare parts and replacement parts, etc.) from our range of products!***
- ***Only insert and lock accessory components into the relevant connection socket when the machine is switched off.***

Requirements for connection to the public mains network

High-performance machines can influence the mains quality by taking current from the mains network. For some types of machines, connection restrictions or requirements relating to the maximum possible line impedance or the necessary minimum supply capacity at the interface with the public network (Point of Common Coupling, PCC) can therefore apply. In this respect, attention is also drawn to the machines' technical data. In this case, it is the responsibility of the operator, where necessary in consultation with the mains network operator, to ensure that the machine can be connected.

2.4 Transport and installation

WARNING



Risk of injury due to improper handling of shielding gas cylinders!

Improper handling and insufficient securing of shielding gas cylinders can cause serious injuries!

- Observe the instructions from the gas manufacturer and any relevant regulations concerning the use of compressed air!
- Do not attach any element to the shielding gas cylinder valve!
- Prevent the shielding gas cylinder from heating up.

⚠ CAUTION**Risk of accidents due to supply lines!**

During transport, attached supply lines (mains leads, control cables, etc.) can cause risks, e.g. by causing connected machines to tip over and injure persons!

- Disconnect all supply lines before transport!

**Risk of tipping!**

There is a risk of the machine tipping over and injuring persons or being damaged itself during movement and set up. Tilt resistance is guaranteed up to an angle of 10° (according to IEC 60974-1).

- Set up and transport the machine on level, solid ground.
- Secure add-on parts using suitable equipment.

**Risk of accidents due to incorrectly installed leads!**

Incorrectly installed leads (mains, control and welding leads or intermediate hose packages) can present a tripping hazard.

- Lay the supply lines flat on the floor (avoid loops).
- Avoid laying the leads on passage ways.

**Risk of injury from heated coolant and its connections!**

The coolant used and its connection or connection points can heat up significantly during operation (water-cooled version). When opening the coolant circuit, escaping coolant may cause scalding.

- Open the coolant circuit only when the power source or cooling unit is switched off!
- Wear proper protective equipment (protective gloves)!
- Seal open connections of the hose leads with suitable plugs.



The units are designed for operation in an upright position!

Operation in non-permissible positions can cause equipment damage.

- ***Only transport and operate in an upright position!***



Accessory components and the power source itself can be damaged by incorrect connection!

- ***Only insert and lock accessory components into the relevant connection socket when the machine is switched off.***
- ***Comprehensive descriptions can be found in the operating instructions for the relevant accessory components.***
- ***Accessory components are detected automatically after the power source is switched on.***



Protective dust caps protect the connection sockets and therefore the machine against dirt and damage.

- ***The protective dust cap must be fitted if there is no accessory component being operated on that connection.***
- ***The cap must be replaced if faulty or if lost!***

3 Intended use

⚠ WARNING

§

Hazards due to improper usage!

The machine has been constructed to the state of the art and any regulations and standards applicable for use in industry and trade. It may only be used for the welding procedures indicated at the rating plate. Hazards may arise for persons, animals and material objects if the equipment is not used correctly. No liability is accepted for any damages arising from improper usage!

- The equipment must only be used in line with its designated purpose and by trained or expert personnel!
- Do not improperly modify or convert the equipment!

3.1 Use and operation solely with the following machines

A suitable wire feed unit (system component) is required in order to operate the welding machine!

The following system components can be combined:

	Titan XQ 350-600 puls D	Phoenix XQ 350-600 puls D	Taurus XQ 350-600 Synergic D
Drive XQ	✔	✔	✔

3.2 Applications

Device control of multi-process welding machines for arc welding covering the following welding procedures:

Machine series	Main procedure for MIG/MAG welding										Secondary process			
	Standard arc					Pulsed arc					TIG welding (Liftarc)	MMA welding	Gouging	Positionweld
	MIG/MAG XQ	forceArc XQ	rootArc XQ	coldArc XQ	wiredArc XQ	MIG/MAG pulse XQ	forceArc puls XQ	rootArc puls XQ	coldArc puls XQ	acArc puls XQ				
Titan XQ AC	✔	✔	✔	✔	✔	✔	✔	✔	✔	✔	✔	✔	✔	✔
Titan XQ / XQ C	✔	✔	✔	✔	✔	✔	✔	✔	✔	✘	✔	✔	✔	✔
Phoenix XQ / XQ C	✔	✔	✔	✘	✘	✔	✔	✔	✘	✘	✔	✔	✔	✔ ^[1]
Taurus XQ / XQ C	✔	✔	✔	✘	✘	✘	✘	✘	✘	✘	✔	✔	✔	✘

[1] Aluminium welding

3.3 Documents which also apply

3.3.1 Warranty

For more information refer to the "Warranty registration" brochure supplied and our information regarding warranty, maintenance and testing at www.ewm-group.com!

3.3.2 Declaration of Conformity



This product corresponds in its design and construction to the EU directives listed in the declaration. The product comes with a relevant declaration of conformity in the original.

The manufacturer recommends carrying out the safety inspection according to national and international standards and guidelines every 12 months.

3.3.3 Welding in environments with increased electrical hazards



Power sources with this marking can be used for welding in an environment with increased electrical hazard (e.g. boilers). For this purpose, appropriate national or international regulations must be followed. The power source must not be placed in the danger zone!

3.3.4 Service documents (spare parts and circuit diagrams)

WARNING



Do not carry out any unauthorised repairs or modifications!

To avoid injury and equipment damage, the unit must only be repaired or modified by specialist, skilled persons!

The warranty becomes null and void in the event of unauthorised interference.

- Appoint only skilled persons for repair work (trained service personnel)!

Original copies of the circuit diagrams are enclosed with the unit.

Spare parts can be obtained from the relevant authorised dealer.

3.3.5 Calibration/Validation

An original certificate is enclosed with the product. The manufacturer recommends calibration / validation at intervals of 12 months.

3.3.6 Part of the complete documentation

This document is part of the complete documentation and valid only in combination with all other parts of these instructions! Read and observe the operating instructions for all system components, especially the safety instructions!

The illustration shows a general example of a welding system.

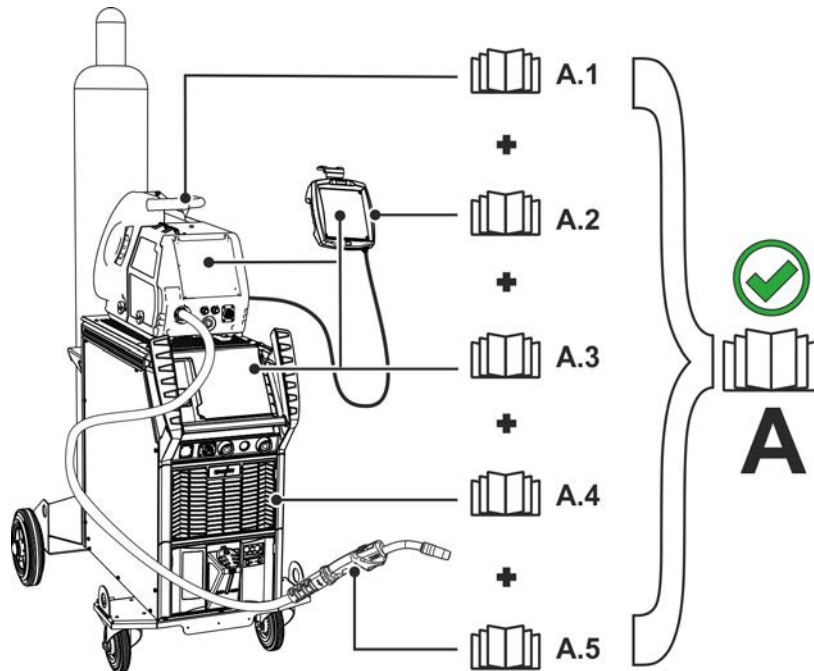

Figure 3-1

The illustration shows a general example of a welding system.

Item	Documentation
A.1	Wire feeder
A.2	Remote adjuster
A.3	Controller
A.4	Power source
A.5	Welding torch
A	Complete documentation

4 Machine description – quick overview

4.1 Machine configuration

The following table shows the different design variants (expansion stages) of the device series XQ:

Type			Figure	Transport properties				Torch cooling		
				Wheel kit, narrow track, without cylinder bracket	Pallet bottom, without cylinder bracket	Wheel kit, single cylinder bracket	Wheel kit, double cylinder bracket	Gas	Water (coolant)	Water (coolant), reinforced pump
F06	R1	G		✗	✗	✓	✗	✓	✗	✗
F06	R1	W		✗	✗	✓	✗	✗	✓	✗
F06	R1	WRF		✗	✗	✓	✗	✗	✗	✓
F06	R2	G		✗	✗	✗	✓	✓	✗	✗
F06	R2	W		✗	✗	✗	✓	✗	✓	✗
F06	R2	WRF		✗	✗	✗	✓	✗	✗	✓
F06	RS	G		✓	✗	✗	✗	✓	✗	✗
F06	RS	W		✓	✗	✗	✗	✗	✓	✗
F06	RS	WRF		✓	✗	✗	✗	✗	✗	✓
F06	P	G		✗	✓	✗	✗	✓	✗	✗
F06	P	W		✗	✓	✗	✗	✗	✓	✗
F06	P	WRF		✗	✓	✗	✗	✗	✗	✓

Figure 4-1

4.2 Front view / side view from the right

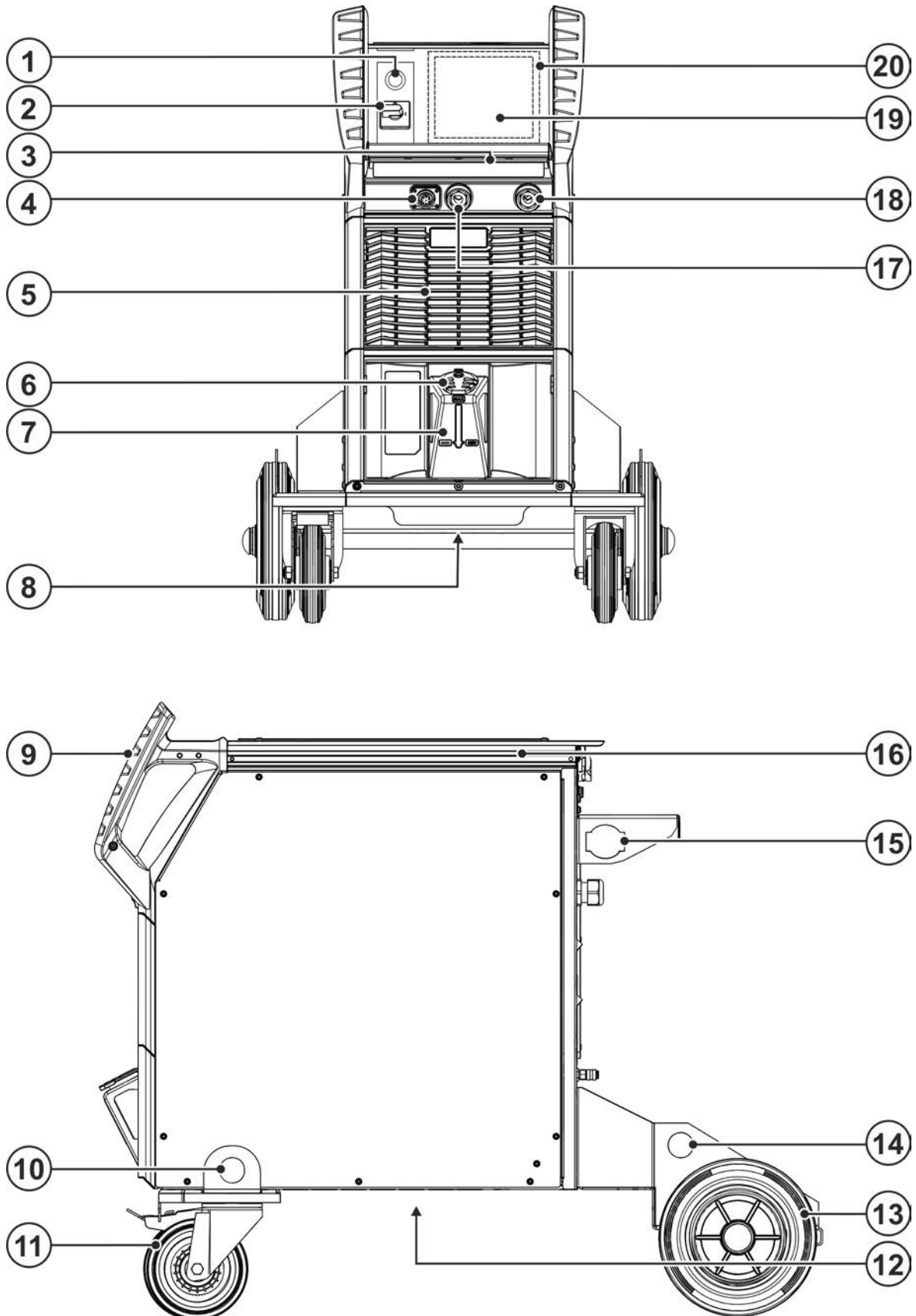





Figure 4-2

Item	Symbol	Description
1		WiFi antenna Factory-fit option, (version OW Expert XQ 2.0 WLG)

Item	Symbol	Description
2		Main Switch Switching the machine on or off.
3		LED status bar - display of operating status The operating status is indicated by a light guide > see 5.1.11.1 chapter.
4		7-pole connection socket (digital) For connecting digital accessory components
5		Cooling air outlet
6		Coolant tank cap
7		Coolant tank > see 5.1.5 chapter
8		Coolant drain plug > see 6.3.2 chapter
9		Carrying handle
10		Lifting lug > see 5.1.1 chapter
11		Wheel The machine can be secured against rolling away on a wheel with a foot lock.
12		Inlet opening for cooling air (torch cooling) Dirt filter can be retrofitted
13		Wheels, fixed castors
14		Lifting lug > see 5.1.1 chapter
15		Intermediate hose package strain relief > see 5.1.8 chapter
16		Aluminium extrusion profile flexFit Individual mounting option for accessories and options
17		Connection socket, “+” welding current How to connect the accessories depends on the welding procedure. Please observe the connection description for the corresponding welding procedure > see 5 chapter.
18		Connection socket, “-” welding current How to connect the accessories depends on the welding procedure. Please observe the connection description for the corresponding welding procedure > see 5 chapter.
19		Machine control (see the relevant control operating instructions)
20		Protective cap > see 5.1.12 chapter

4.3 Rear view / side view from left

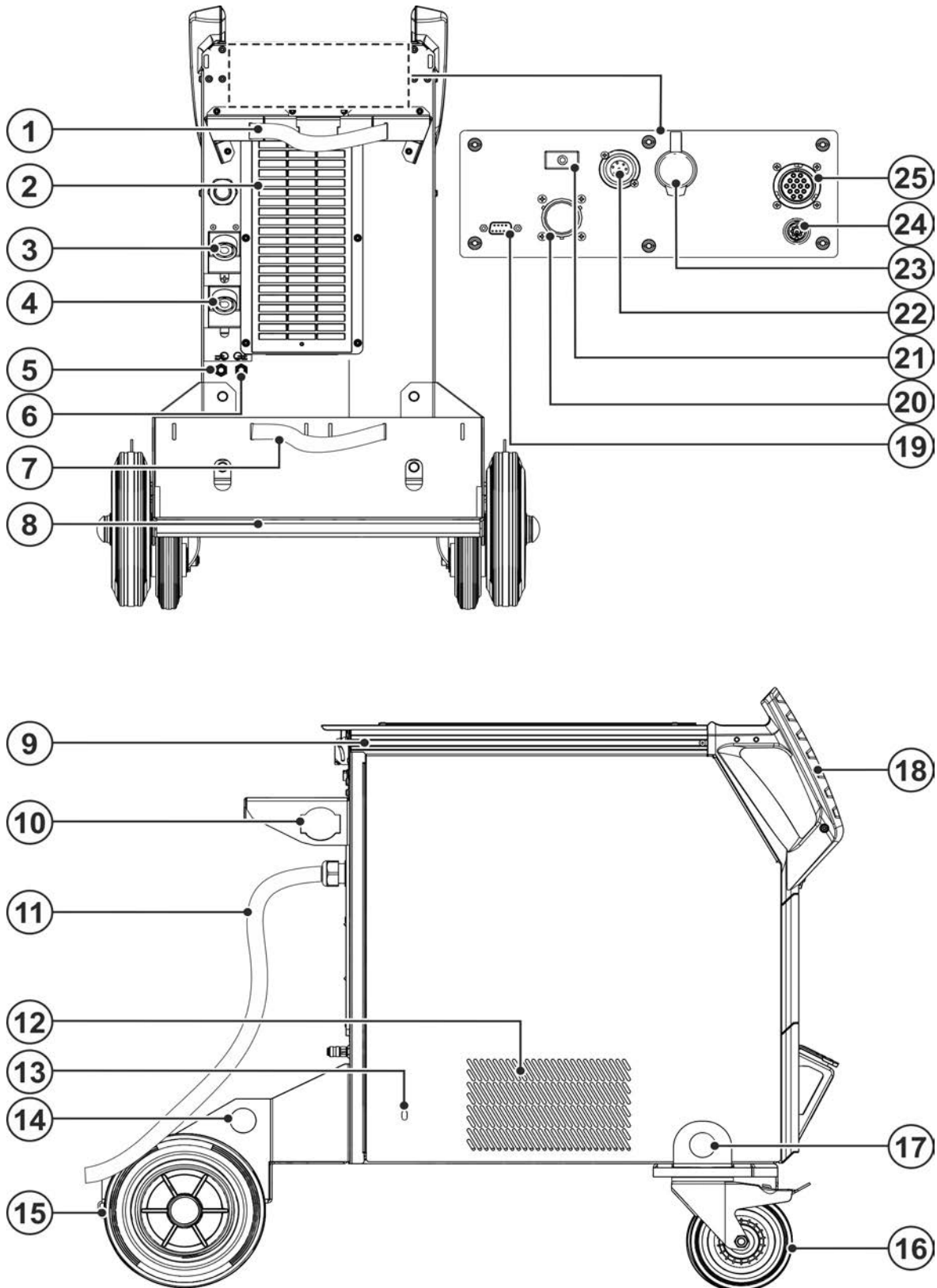













Figure 4-3

Item	Symbol	Description
1		Securing elements for shielding gas cylinder (strap/chain)
2		Cooling air inlet Dirt filter optional > see 6.3.1 chapter

Item	Symbol	Description
3		Connection socket, “+” welding current How to connect the accessories depends on the welding procedure. Please observe the connection description for the corresponding welding procedure > see 5 chapter.
4		Connection socket, “-” welding current How to connect the accessories depends on the welding procedure. Please observe the connection description for the corresponding welding procedure > see 5 chapter.
5		Quick connect coupling (red) coolant return
6		Quick connect coupling (blue) coolant supply
7		Securing elements for shielding gas cylinder (strap/chain)
8		Bracket for shielding gas cylinder
9		Aluminium extrusion profile flexFit Individual mounting option for accessories and options
10		Intermediate hose package strain relief > see 5.1.8 chapter
11		Mains connection cable > see 5.1.10 chapter
12		Outlet opening cooling air (torch cooling)
13		Service opening for coolant pump > see 7.5 chapter
14		Lifting lug > see 5.1.1 chapter
15		Wheels, fixed castors
16		Wheels, guide castors
17		Lifting lug > see 5.1.1 chapter
18		Carrying handle
19		Connection socket (9-pole) - D-Sub PC interface > see 5.7 chapter
20		Interface for automated welding 19-pin (analogue) Optional > see 5.6.1 chapter
21		Key button, Automatic cutout Wire feed motor supply voltage fuse (press to reset a triggered fuse)
22		7-pole connection socket (digital) For connecting digital accessory components
23		Connection socket - RJ45 - Option Network connection > see 5.9 chapter
24		Connection socket, hand scanner Component identification Xnet - optional - > see 5.8 chapter
25		14-pole connection socket Wire feeder control cable connection

5 Design and function

⚠ WARNING



Risk of injury from electrical voltage!

Contact with live parts, e.g. power connections, can be fatal!

- Observe the safety information on the first pages of the operating instructions!
- Commissioning must be carried out by persons who are specifically trained in handling power sources!
- Connect connection or power cables while the machine is switched off!

Read and observe the documentation to all system and accessory components!

5.1 Transport and installation

5.1.1 Lifting by crane

⚠ WARNING



Risk of injury during lifting by crane!

When lifting the machine by crane, persons may be severely injured by falling machines or mount-on components.

- Simultaneous lifting of system components such as power source, wire feeder or cooling unit without suitable crane components is not allowed. Each system component has to be lifted separately!
- Remove any supply leads and accessories before lifting by crane (e.g. hose package, wire spool, shielding gas cylinder, toolbox, wire feeder, remote control, etc.)!
- Properly close and lock all casing covers and protective caps before lifting by crane!
- Use the correct number of hoisting equipment of the right size in the correct position! Observe craning principle > see 5.1.1.1 chapter!
- Devices with lifting eyes: Always lift all lifting eyes simultaneously!
- Devices with pallet bottom (feet): Pull the straps through the openings of the feet (hooking hoisting equipment in the openings is not sufficient).
- When using retrofitted craning frames etc.: always use at least two lifting points positioned as far apart as possible – observe option description.
- Avoid any jerky movements!
- Ensure that the load is distributed evenly! • Use chain hoists and chain slings of the same length only!
- Stay outside the danger zone underneath the machine!
- Observe the regulations regarding occupational safety and accident prevention for the respective country.

5.1.1.1 Craning principle

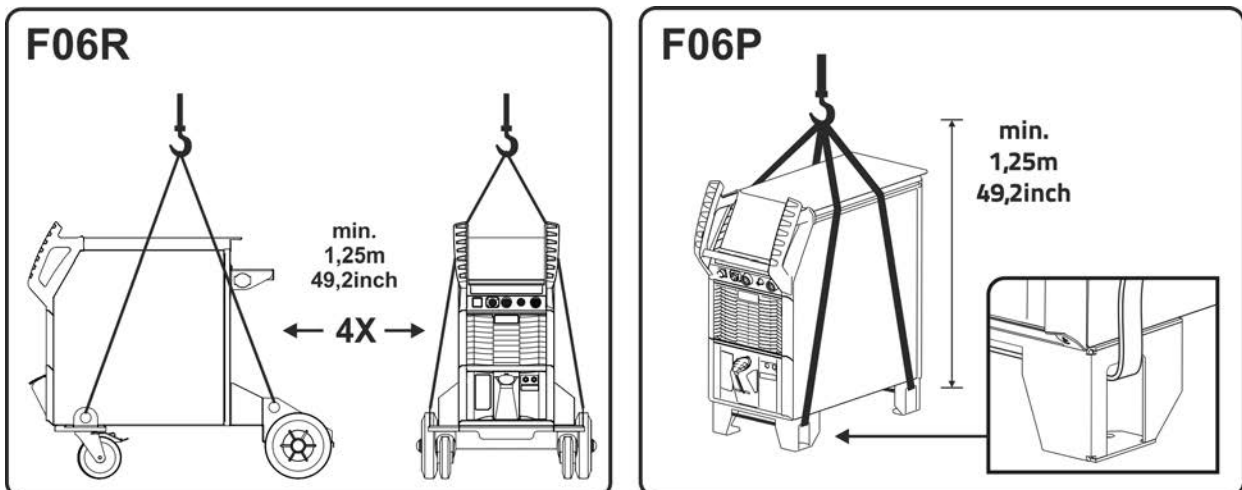

Figure 5-1

5.1.2 Ambient conditions



The machine must not be operated in the open air and must only be set up and operated on a suitable, stable and level base!

- **The operator must ensure that the ground is non-slip and level, and provide sufficient lighting for the place of work.**
- **Safe operation of the machine must be guaranteed at all times.**



Equipment damage due to contamination!

Unusually high amounts of dust, acids, corrosive gases or substances can damage the machine (observe maintenance intervals > see 6.3 chapter).

- **Avoid large amounts of smoke, steam, oily fumes, grinding dust and corrosive ambient air!**

5.1.2.1 In operation

Temperature range of the ambient air:

- -25 °C to +40 °C (-13 °F to 104 °F) ^[1]

Relative humidity:

- up to 50 % at 40 °C (104 °F)
- up to 90 % at 20 °C (68 °F)

5.1.2.2 Transport and storage

Storage in a closed room, temperature range of the ambient air:

- -30 °C to +70 °C (-22 °F to 158 °F) ^[1]

Relative humidity

- up to 90 % at 20 °C (68 °F)

^[1] Ambient temperature dependent on coolant! Observe the coolant temperature range of the torch cooling

5.1.3 Machine cooling



Insufficient ventilation results in a reduction in performance and equipment damage.

- **Observe the ambient conditions!**
- **Keep the cooling air inlet and outlet clear!**
- **Observe the minimum distance of 0.5 m from obstacles!**

5.1.4 Workpiece lead, general

CAUTION



Risk of burning due to incorrect welding current connection!

If the welding current plugs (machine connections) are not locked or if the workpiece connection is contaminated (paint, corrosion), these connections and leads can heat up and cause burns when touched!

- Check welding current connections on a daily basis and lock by turning to the right when necessary.
- Clean workpiece connection thoroughly and secure properly. Do not use structural parts of the workpiece as welding current return lead!

5.1.5 Welding torch cooling system



Material damage due to unsuitable coolants!

Unsuitable coolant, coolants mixed with other types / liquids or use in an unsuitable temperature range will result in material damage and loss of the manufacturer's warranty!

- **Operation without coolant is not permitted (dry running will destroy the coolant pump)!**
- **Only use the coolants described in these instructions for the specified ambient conditions (temperature range) > see 5.1.5.2 chapter.**
- **Do not mix coolants of different types (including those described in these instructions).**
- **When changing the coolant, all liquid must be replaced and the cooling system flushed.**

Dispose of the coolant in accordance with local regulations and the material safety data sheets.

5.1.5.1 Functional characteristics

The cooling system of this machine series is designed to optimise the operating conditions and is temperature- and flow-monitored to protect against damage. Limit values > see 8.2 chapter for warnings and errors in the machine (adjustable depending on control system) are stored for monitoring and control of the cooling system. If the cooling system is faulty or overloaded, an error message appears and the welding process is switched off in a controlled manner.

















5.1.5.2 Permitted torch coolant

Coolant	Temperature range
blueCool -10	-10 °C to +40 °C (14 °F to +104 °F)
KF 23E (Standard)	-10 °C to +40 °C (14 °F to +104 °F)
KF 37E	-20 °C to +30 °C (-4 °F to +86 °F)
blueCool -30	-30 °C to +40 °C (-22 °F to +104 °F)

















5.1.5.3 Maximal hose package length

All information relates to the total hose package length of the complete welding system and presents exemplary configurations (of components of the EWM product portfolio with standard lengths). A straight kink-free installation is to be ensured, taking into account the max. delivery height.

Pump: Pmax = 3,5 bar (0.35 MPa)

Power source	Hose package	Wire feeder	miniDrive	Welding torch	Max.
Compact			 (25 m / 82 ft.)	 (5 m / 16 ft.)	30 m 98 ft.
	 (20 m / 65 ft.)			  (5 m / 16 ft.)	
Decompact	 (25 m / 82 ft.)			 (5 m / 16 ft.)	
	 (15 m / 49 ft.)		 (10 m / 32 ft.)	 (5 m / 16 ft.)	

Pump: Pmax = 4.5 bar (0.45 MPa)

Power source	Hose package	Wire feeder	miniDrive	Welding torch	Max.
Compact			 (25 m / 82 ft.)	 (5 m / 16 ft.)	30 m 98 ft.
	 (30 m / 98 ft.)			  (5 m / 16 ft.)	40 m 131 ft.
Decompact	 (40 m / 131 ft.)			 (5 m / 16 ft.)	45 m 147 ft.
	 (40 m / 131 ft.)		 (25 m / 82 ft.)	 (5 m / 16 ft.)	70 m 229 ft.

5.1.5.4 Adding coolant

After switching on the machine, the coolant pump runs for a maximum of 2 min. (Filling hose package). If the machine does not detect a sufficient coolant flow during this time, the coolant pump is switched off (protection against damage in dry run). At the same time, the welding data display signals the coolant error. If there is a sufficient coolant flow, the coolant pump is switched off already 2 min. before the end (ready for operation).

If there is less coolant in the coolant tank than the minimum required you may need to vent the coolant circuit. In this case the welding machine will automatically shut down the coolant pump and signal an error, > see 7.4 chapter.

The unit is supplied ex works with a minimum level of coolant.

The level of coolant must never fall below the "MIN" mark.

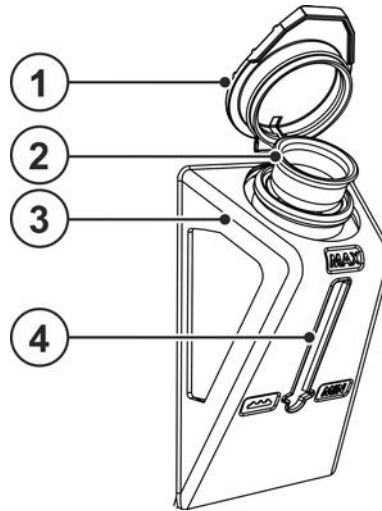

Figure 5-2

Item	Symbol	Description
1		Coolant tank cap
2		Coolant filter sieve
3		Coolant tank > see 5.1.5 chapter
4		Filling level display MIN -----minimum coolant level MAX -----maximum coolant level

- Pull off the coolant tank sealing cover.
- Check filter sieve for cleanliness, clean if necessary and reinsert.
- Top up coolant up to the upper filling level gauge "MAX" and push sealing cover back on.
- Switch on the power source at the main switch.

5.1.6 Notes on the installation of welding current leads

- Incorrectly installed welding current leads can cause faults in the arc (flickering).
- Lay the workpiece lead and hose package of power sources without HF igniter (MIG/MAG) for as long and as close as possible in parallel.
- Lay the workpiece lead and hose package of power sources with HF igniter (TIG) for as long as possible in parallel with a distance of 20 cm to avoid HF sparkover.
- Always keep a distance of at least 20 cm to leads of other power sources to avoid interferences
- Always keep leads as short as possible! For optimum welding results max. 30 m (welding lead + intermediate hose package + torch lead).

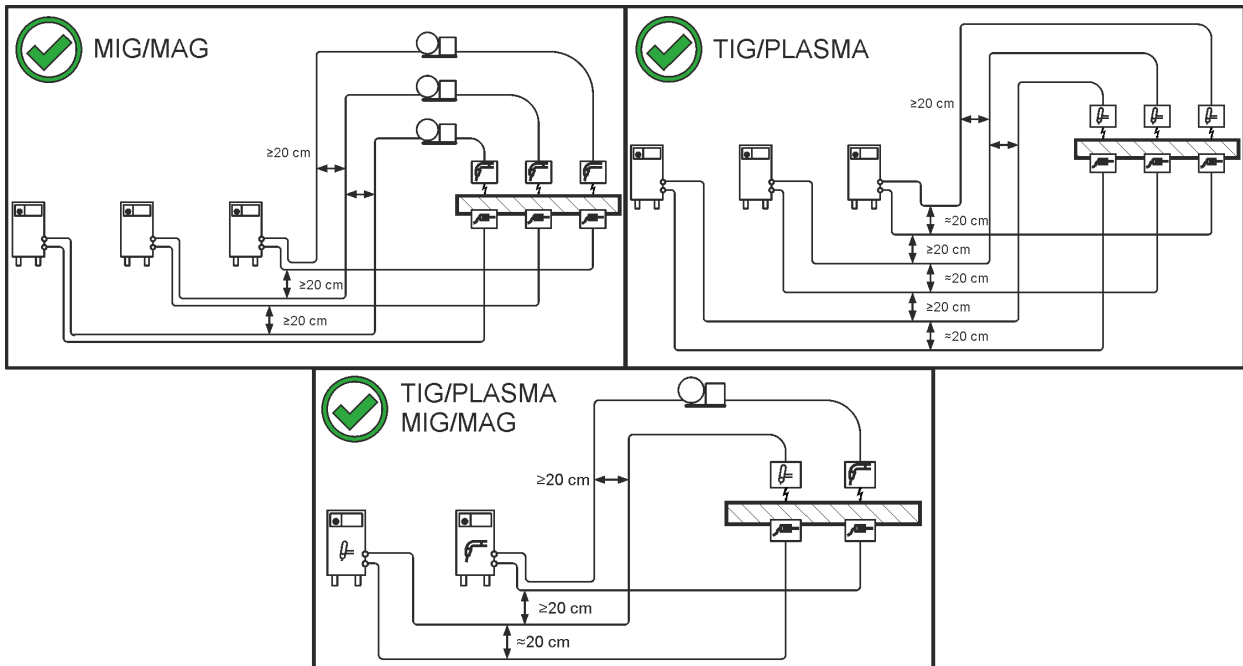

Figure 5-3

- Use an individual welding lead to the workpiece for each welding machine!

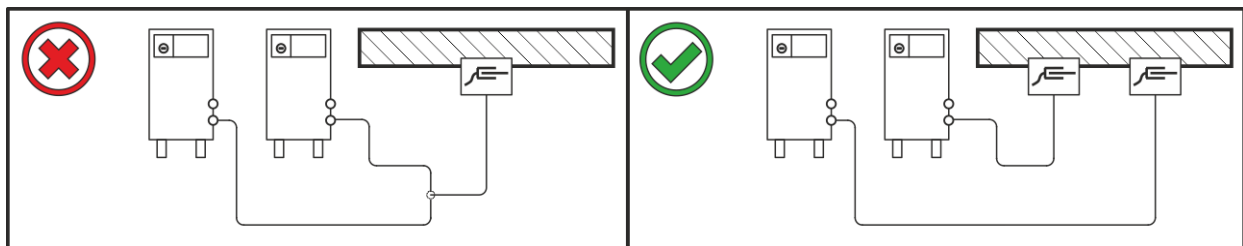

Figure 5-4

- Fully unroll welding current leads, torch hose packages and intermediate hose packages. Avoid loops!
- Always keep leads as short as possible!

Lay any excess cable lengths in meanders.

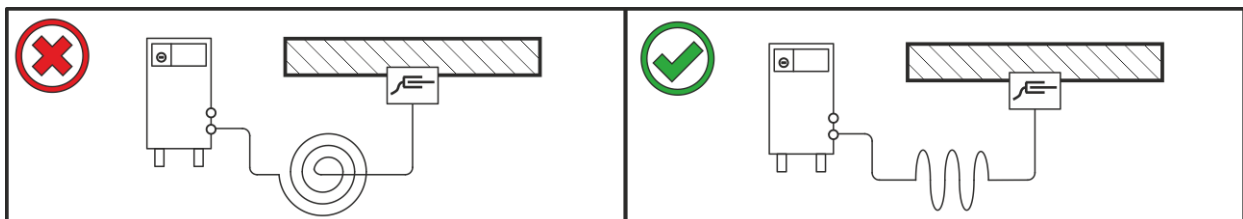

Figure 5-5

5.1.7 Stray welding currents

⚠ WARNING



Risk of injury due to stray welding currents!

Stray welding currents can destroy protective earth conductors, damage machines and electronic devices and cause overheating of components, leading to fire.

- Check that all welding current connections are firmly secured and electrical connections are in perfect condition.
- Set up, attach or suspend all conductive power source components such as casing, transport vehicles and crane frames so they are insulated.
- Do not place any other electronic devices such as drills or angle grinders on the power source, transport vehicle or crane frames unless they are insulated.
- Always put welding torches and electrode holders on an insulated surface when they are not in use.

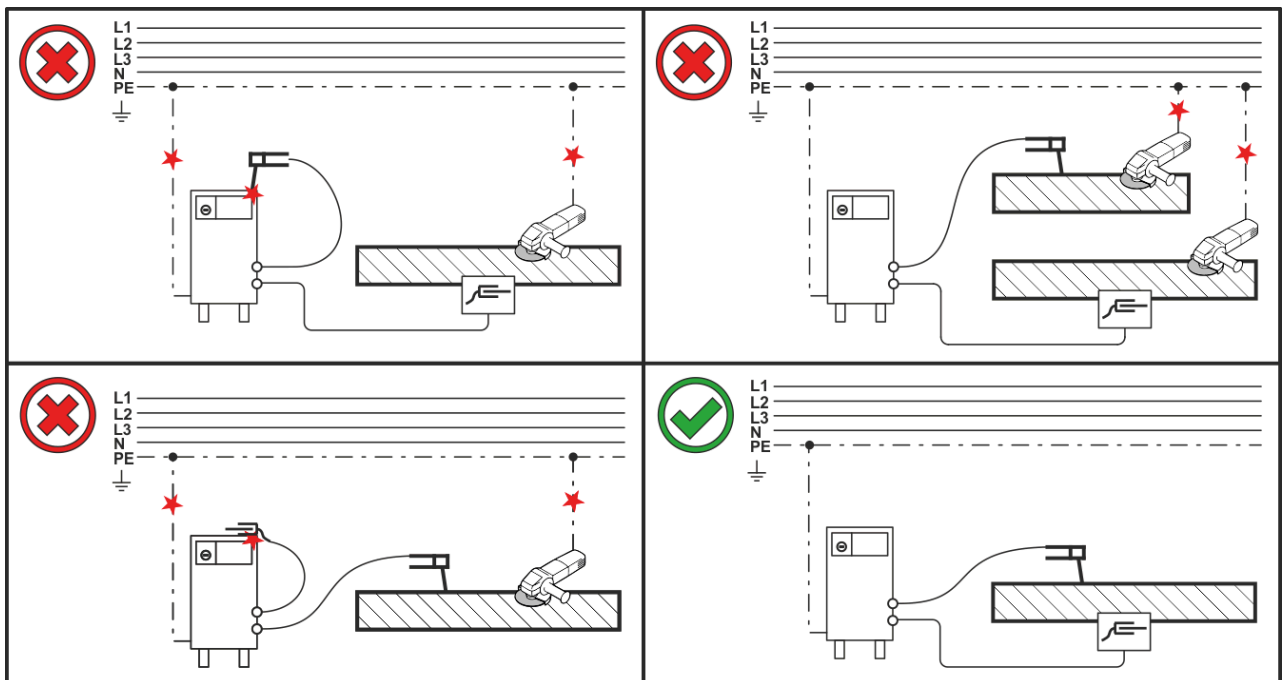

Figure 5-6

5.1.8 Connecting the intermediate hose package to the power source

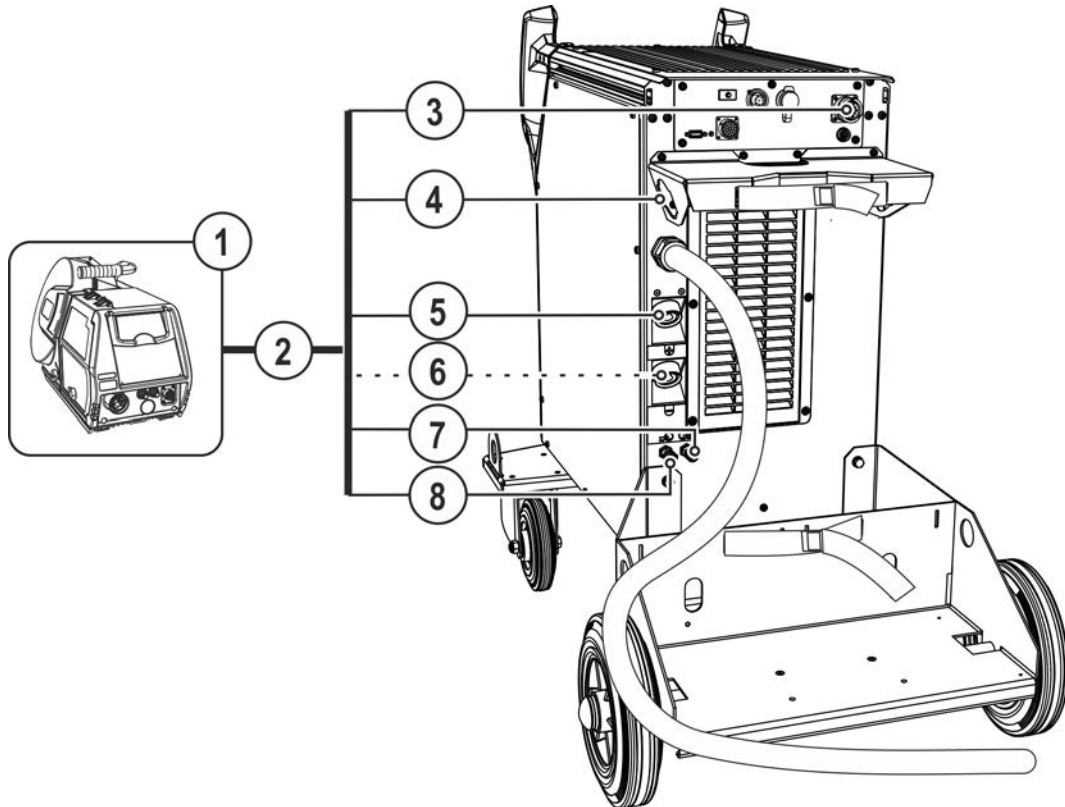

Figure 5-7

Item	Symbol	Description
1		Wire feed unit
2		Intermediate hose package
3	 DV1	14-pole connection socket Wire feeder control cable connection
4		Intermediate hose package strain relief > see 5.1.8 chapter
5		Connection socket, “+” welding current • Standard MIG/MAG welding (intermediate hose package)
6		Connection socket, “-” welding current Connection for welding current plug from intermediate hose package • MIG/MAG flux cored wire welding • TIG welding
7		Quick connect coupling (blue) coolant supply
8		Quick connect coupling (red) coolant return

- Insert the hose package end of the intermediate hose package from the outside through the strain relief of intermediate hose package and then lock by turning to the right.
- Insert the control cable through the recess in the gas cylinder bracket, insert the cable plug into the into the connection socket (14-pole) and secure with crown nut (the plug can only be inserted into the connection socket in one position).
- Insert the plug on the welding current lead into the welding current connection socket "+" and lock.
- Lock connecting nipples of the cooling water tubes into the corresponding quick connect couplings: Return line red to quick connect coupling, red (coolant return) and supply line blue to quick connect coupling, blue (coolant supply).

Some wire electrodes (e.g. self-shielding cored wire) are welded using negative polarity. In this case, the welding current lead should be connected to the "-" welding current socket, and the workpiece lead should be connected to the "+" welding current socket. Observe the information from the electrode manufacturer!

5.1.8.1 Intermediate hose package strain relief



Property damage due to strain relief not installed or not installed correctly!

The strain relief absorbs tensile forces on cables, plugs and sockets.

If strain reliefs are not installed or not installed correctly, the connector plugs or sockets may be damaged.

- **The attachment must always take place on both sides of the intermediate hose package!**
- **The connections of the hose package must be locked properly!**

5.1.8.2 Possible attachment points

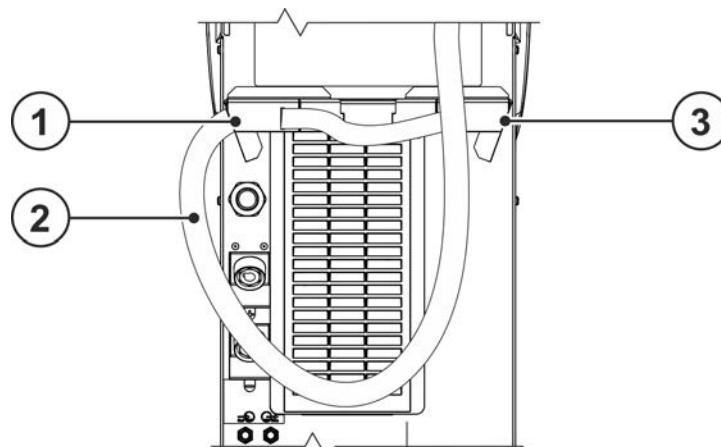

Figure 5-8

Item	Symbol	Description
1	DV1	Intermediate hose package strain relief For wire feeder 1
2		Intermediate hose package
3	DV2	Intermediate hose package strain relief For wire feeder 2

5.1.8.3 Locking the strain relief EWM intermediate hose package

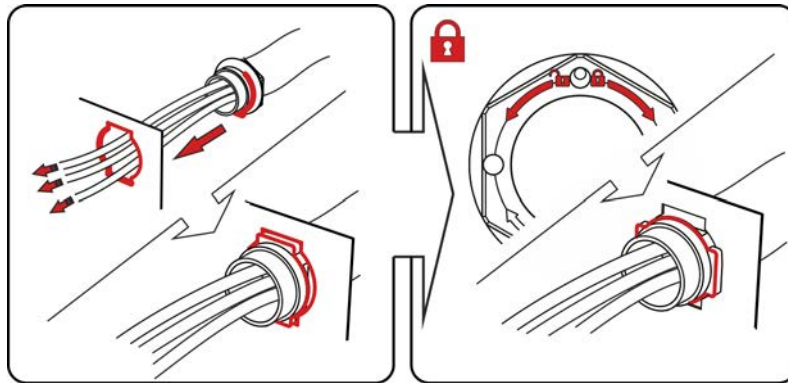

Figure 5-9

5.1.9 Shielding gas supply (shielding gas cylinder for welding machine)

⚠ WARNING



Risk of injury due to improper handling of shielding gas cylinders! Improper handling and insufficient securing of shielding gas cylinders can cause serious injuries!

- Observe the instructions from the gas manufacturer and any relevant regulations concerning the use of compressed air!
- Lift the shielding gas cylinder onto the receptacle of the shielding gas cylinder and secure with both safety belts provided on the device as standard! Belts must be tight.
- Do not attach any element to the shielding gas cylinder valve!
- Prevent the shielding gas cylinder from heating up.

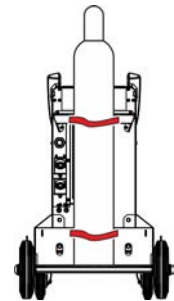

An unhindered shielding gas supply from the shielding gas cylinder to the welding torch is a fundamental requirement for optimum welding results. In addition, a blocked shielding gas supply may result in the welding torch being destroyed.

- All shielding gas connections must be gas tight.

5.1.9.1 Pressure regulator connection

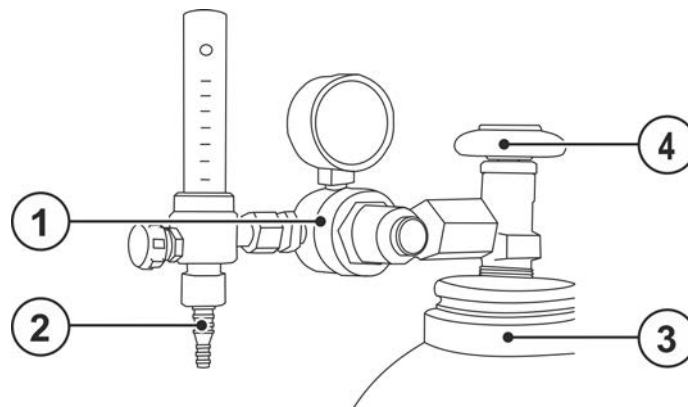

Figure 5-10

Item	Symbol	Description
1		Pressure regulator
2		Output side of the pressure regulator
3		Shielding gas cylinder
4		Cylinder valve

- Before connecting the pressure regulator to the gas cylinder, open the cylinder valve briefly to blow out any dirt.
- Tighten the pressure regulator screw connection on the gas bottle valve to be gas-tight.
- Screw the gas hose connection to the outlet side of the pressure regulator gas-tight.

5.1.10 Mains connection

DANGER



Hazards caused by improper mains connection!

An improper mains connection can cause injuries or damage property!

- The connection (mains plug or cable), the repair or voltage adjustment of the device must be carried out by a qualified electrician in accordance with the respective local laws or national regulations!
- The mains voltage indicated on the rating plate must match the supply voltage.
- Only operate machine using a socket that has correctly fitted protective earth.
- Mains plug, socket and lead must be checked by a qualified electrician on a regular basis!
- When operating the generator, always ensure it is earthed as stipulated in the operating instructions. The network created must be suitable for operating machines according to protection class I.



The welding power source is equipped with an internal clamp device for multiple mains voltages. The currently set mains voltage of the power source must match the supply voltage! The following steps have to be carried out:

- **Visual inspection - comparison between the currently set mains voltage at the power source and the supply voltage > see 5.1.10.1 chapter**
- **Adaptation and marking of the mains voltage > see 5.1.10.2 chapter**
- **Carry out a safety check after intervention in the machine > see 5.1.10.3 chapter!**

5.1.10.1 Visual inspection of the set mains voltage

The set mains voltage is marked on the rating plate and the label on the mains connection cable by a marking. If the marked mains voltage range coincides with the supply voltage, further commissioning may take place. If the specifications for mains and supply voltage do not match, the mains voltage in the machine must be reconnected to the supply voltage > see 5.1.10.2 chapter.

Removed or not clearly identifiable adhesive labels must be replaced!

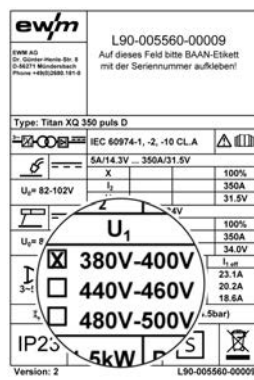

Example of rating plate

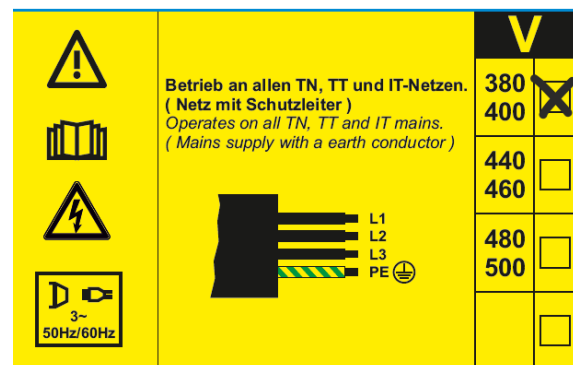

Adhesive label of mains connection cable

Figure 5-11

5.1.10.2 Adjusting the power source to the mains voltage

The mains voltage is adapted by replugging the operating voltage plug on the printed circuit board VB xx0 into the power source.

The machine can be reconnected between three possible voltage ranges:

1. 380 V to 400 V (ex works)
2. 440 V to 460 V
3. 480 V to 500 V

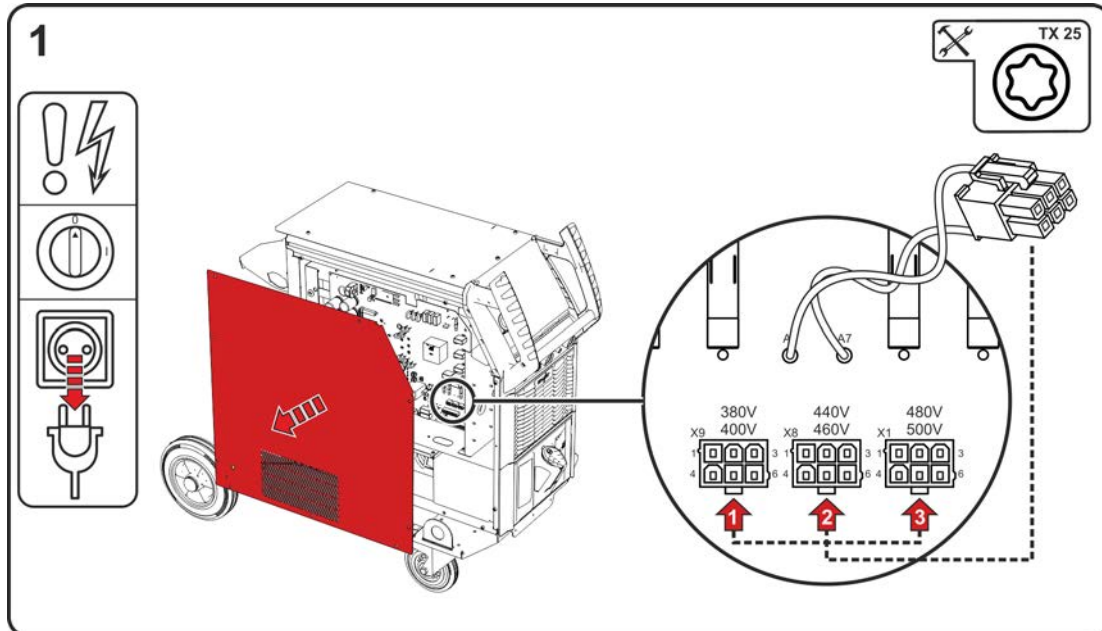

Figure 5-12

- Switch off machine at the main switch.
- Disconnect mains plug.
- Loosen the fastening screws from the housing cover. Open the housing cover at the side and lift it up.
- Reconnect operating voltage plug (printed circuit board VB xx0) to the corresponding voltage range of the supply voltage (380V/400V ex works).
- Hook housing cover from above into the aluminium continuous casting profile flexFit and secure with fastening screws.
- Install a mains plug which is permissible for the selected mains voltage to the mains cable. Identify the selected mains voltage on the rating plate and on the adhesive label of mains connection cable.

5.1.10.3 Re-commissioning

WARNING



Dangers resulting from failure to perform test after conversion!

Before reconnection, "Inspection and Testing during Operation" according to IEC/BS EN 60974-4 "Arc welding systems – Inspection and Testing during Operation" has to be performed!

- Perform test to IEC / DIN EN 60974-4!

5.1.10.4 Mains configuration

The machine may be connected to:

- a three-phase system with four conductors and an earthed neutral conductor
- a three-phase system with three conductors of which any one can be earthed, e.g. the outer conductor

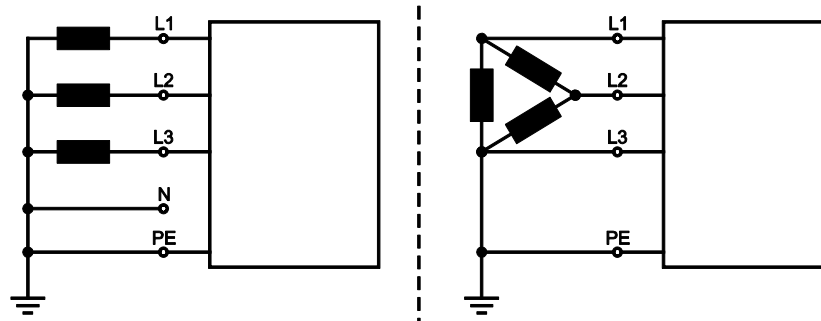

Figure 5-13

Legend

Item	Designation	Colour code
L1	Outer conductor 1	brown
L2	Outer conductor 2	black
L3	Outer conductor 3	grey
N	Neutral conductor	blue
PE	Protective conductor	green-yellow

- Insert mains plug of the switched-off machine into the appropriate socket.

5.1.11 Switching on and system diagnosis

Each time the system is switched on, the entire welding system runs data synchronization and the system diagnostics of the individual components. The duration of the start time (switching on up to welding readiness) depends on the number of connected system components and the information to be exchanged under these devices. This time can take from several seconds to several minutes (e.g. for the system components interconnected for the first time). During this start phase, the system components will display the controller type and, if applicable, software information in the welding data display (if available). This start phase is terminated by display of the nominal values for current, voltage or wire feed speed.

Operation of machine fan and coolant pump

The machine fan and coolant pump in this machine series are temperature- and state-controlled. This ensures that subsystems of the welding machine run only when they are needed. After each switching on, the machine fans run at full power for approx. 2 s, e.g. to blow out dust deposits.

5.1.11.1 LED status bar - display of operating status

A light guide on the front of the housing (LED status bar) shows the user the current operating status of the device.

Colour of the LED status bar	Operating status
white (change: light/dark)	Booting (switching on up to welding readiness)
blue	Ready for welding
blue (change: light/dark)	Power-saving mode Standby
green	Welding
yellow	Warning > see 7.2 chapter
red	Error > see 7.1 chapter

5.1.12 Protective flap, welding machine control

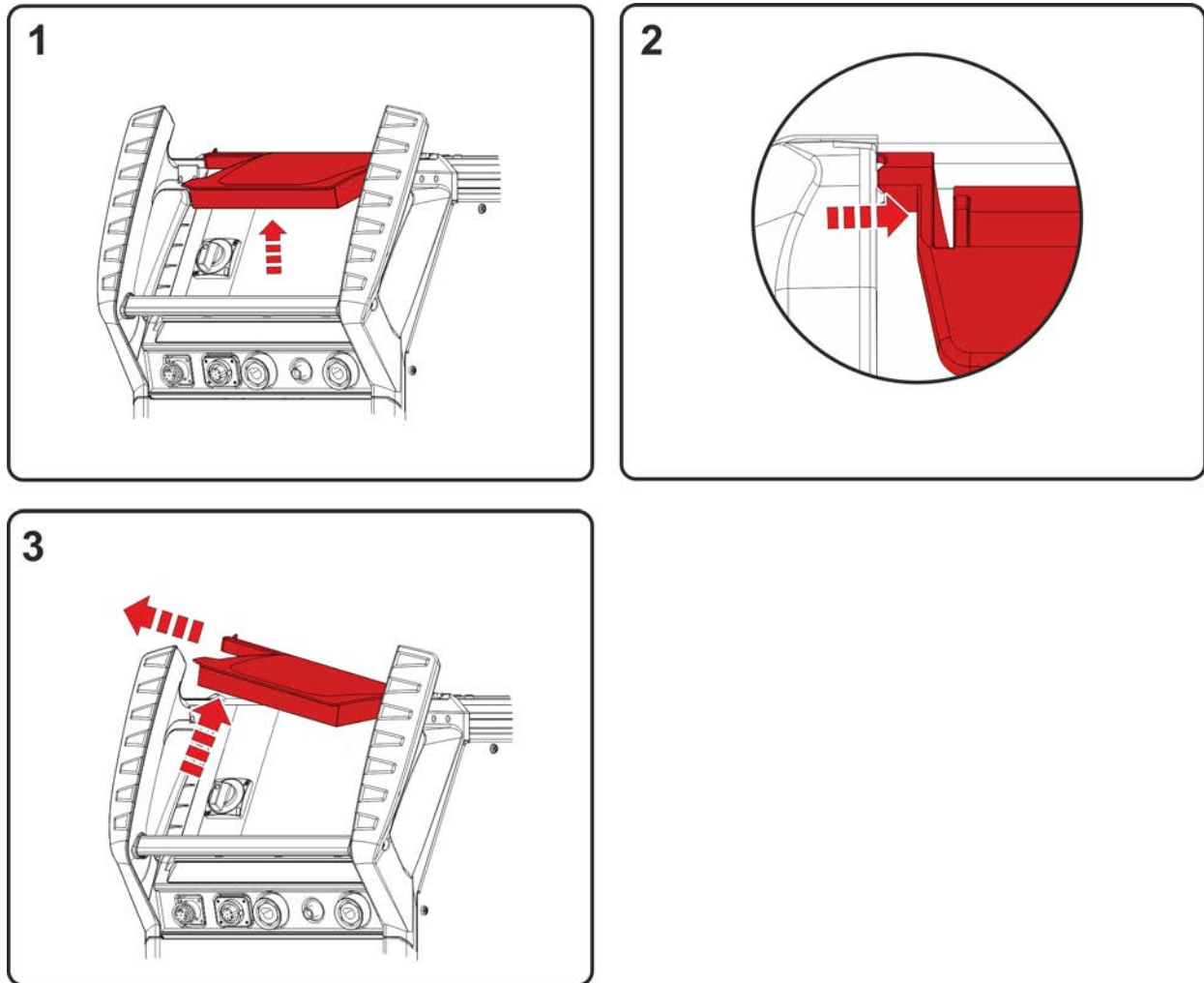

Figure 5-14

- Open the protective cap.
- Apply slight pressure on the left connecting bridge (figure) until the flap's fastening pin can be removed to the left, from top.

5.2 MIG/MAG welding

5.2.1 Connection for workpiece lead

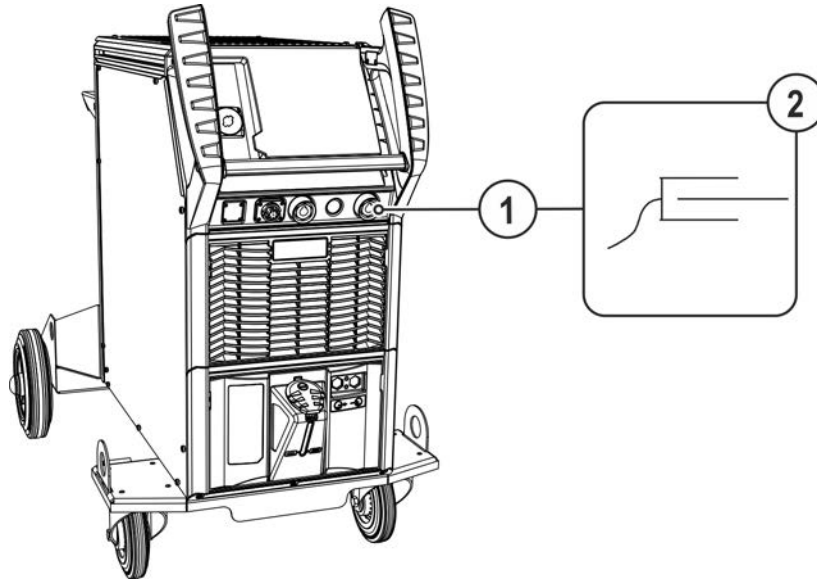



Figure 5-15

Item	Symbol	Description
1		Connection socket, “-” welding current Workpiece lead connection
2		Workpiece

- Insert the plug on the workpiece lead into the “-” welding current connection socket and lock.

Some wire electrodes (e.g. self-shielding cored wire) are welded using negative polarity. In this case, the welding current lead should be connected to the “-” welding current socket, and the workpiece lead should be connected to the “+” welding current socket. Observe the information from the electrode manufacturer!

5.2.2 Welding task selection

For selection of the welding task and for general operation see the relevant Control operating instructions.

5.2.3 Setting the shielding gas volume (gas test)/rinse hose package

- Shielding gas supply as described in chapter Transport and positioning > see 5.1.9 chapter.
- Slowly open the gas cylinder valve.
- Open the pressure regulator.
- Switch on the power source at the main switch.
- Set the relevant gas quantity for the application on the pressure regulator.
- You can activate the gas test on the machine control (see Control operating instructions) or by pressing the "Gas test/rinse hose package" push-button briefly (welding voltage and wire feed motor remain switched off – no unintentional ignition of the arc). Some welding systems have several push-buttons to set the shielding gas. The push-button is generally found near a wire feeder.

Shielding gas flows for around 25 seconds or until the button is pressed again.

If the shielding gas setting is too low or too high, this can introduce air to the weld pool and may cause pores to form. Adjust the shielding gas quantity to suit the welding task!

Welding process	Recommended shielding gas quantity
MAG welding	Wire diameter x 11.5 = l/min
MIG brazing	Wire diameter x 11.5 = l/min
MIG welding (aluminium)	Wire diameter x 13.5 = l/min (100 % argon)

Helium-rich gas mixtures require a higher gas volume!

The table below can be used to correct the gas volume calculated where necessary:

Shielding gas	Factor
75% Ar/25% He	1.14
50% Ar/50% He	1.35
25% Ar/75% He	1.75
100% He	3.16

5.3 TIG welding

5.3.1 Connection for workpiece lead

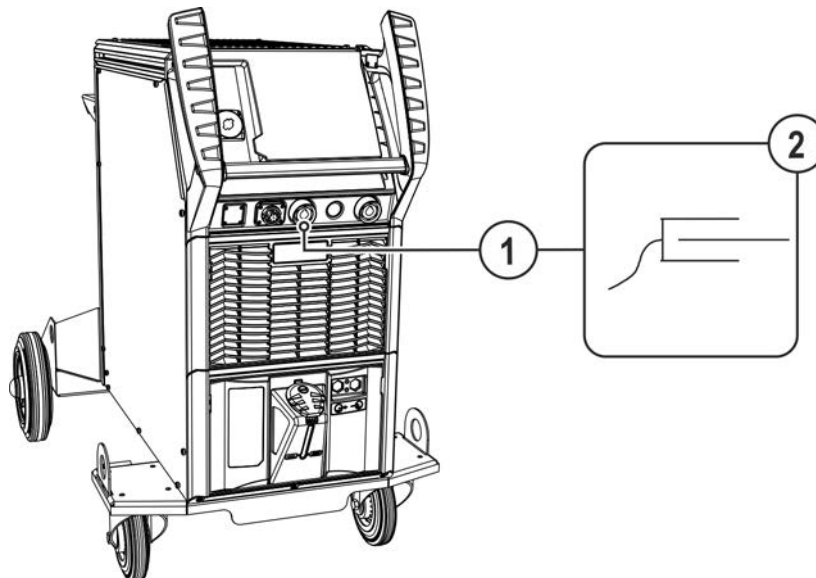

Figure 5-16

Item	Symbol	Description
1		Workpiece
2		Connection socket, "+" welding current • TIG welding: Workpiece connection

- Insert the cable plug on the work piece lead into the "+" welding current connection socket and lock by turning to the right.

5.3.2 Welding task selection

For selection of the welding task and for general operation see the relevant Control operating instructions.

5.4 MMA welding

5.4.1 Connecting the electrode holder and workpiece lead

CAUTION

Risk of crushing and burns!
When changing stick electrodes there is a risk of crushing and burns!

- Wear appropriate and dry protective gloves.
- Use an insulated pair of tongs to remove the used stick electrode or to move welded work-pieces.

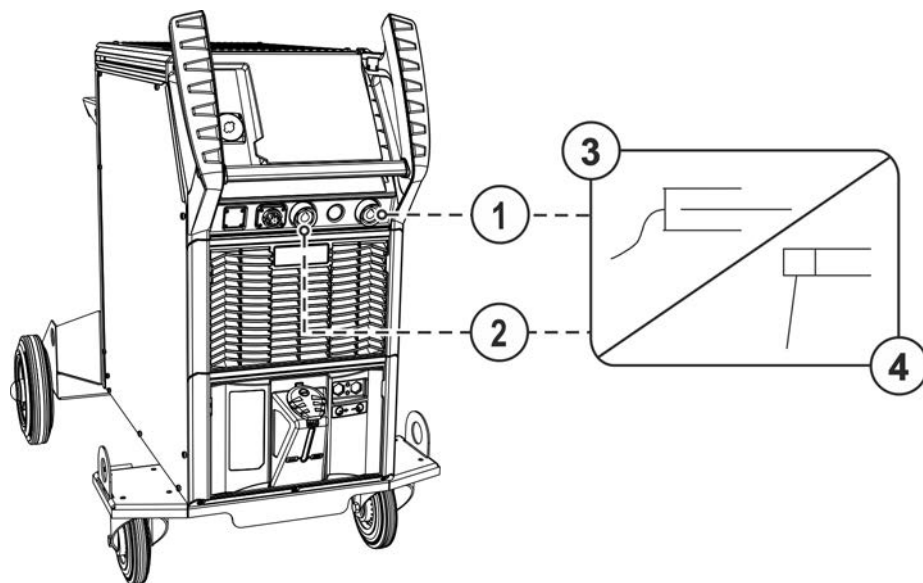

Figure 5-17

Item	Symbol	Description
1		Connection socket, welding current “-”
2		Connection socket, “+” welding current
3		Workpiece
4		Electrode holder

- Insert the electrode holder plug and workpiece lead into the welding current socket depending on application and lock in place by turning to the right. The corresponding polarity will be based on the information of the electrode manufacturer on the electrode packaging.

5.4.2 Welding task selection

For selection of the welding task and for general operation see the relevant Control operating instructions.

5.5 Remote control

The remote controls are operated via the 19-pole remote control connection socket (analogue) or the 7-pole remote control connection socket (digital), depending on the model.

Read and observe the documentation to all system and accessory components!

5.6 Interfaces for automation

⚠ WARNING



Do not carry out any unauthorised repairs or modifications!
To avoid injury and equipment damage, the unit must only be repaired or modified by specialist, skilled persons!
The warranty becomes null and void in the event of unauthorised interference.

- Appoint only skilled persons for repair work (trained service personnel)!



Unsuitable control cables or incorrect input/output signal assignment can cause damage to the machine. Use shielded control cables only.

5.6.1 Automation interface

⚠ WARNING



No function of the external interrupt equipment (emergency stop switch)!
If the emergency stop circuit has been set up using an external interrupt equipment connected to the interface for automated welding, the machine must be configured for this setup. If this is not observed, the power source will ignore the external interrupt equipment and will not shut down!

- Remove jumper 1 on the corresponding control board (to be done only by qualified service personnel)!

These accessory components can be retrofitted as an option > see 9 chapter.

Pin	Input / Output	Name	Figure
A	Output	PE ----- Connection for cable screen	
D	Output (open collector)	IGRO ---- Current flows signal I>0 (maximum load 20 mA / 15 V) 0 V = welding current flows	
E/R	Input	Not-Aus - Emergency stop for higher level shut-down of the power source.	
F	Output	0V ----- Reference potential	
G/P	Output	IGRO ---- Current relay contact to the user, potential-free (max. +/-15 V / 100 mA)	
H	Output	Uist ----- Welding voltage measured against pin F, 0-10 V (0 V = 0 V; 10 V = 100 V) ^[1]	
L	Input	STA/STP Start = 15 V / Stop = 0 V ^[2]	
M	Output	+15 V ---- Power supply (max. 75 mA)	
N	Output	-15 V ---- Power supply (max. 25 mA)	
S	Output	0 V ----- Reference potential	
T	Output	list ----- Welding current measured against pin F; 0-10 V (0 V = 0 A, 10 V = 1000 A) ^[3]	

^[1] Accuracy type $\pm (0.05 \text{ V} + 2.5 \% \text{ of the measured value})$

^[2] The operating mode is specified by the wire feeder (the start / stop function corresponds to the operation of the torch trigger and is used, for instance, in mechanized applications).

^[3] Accuracy type $\pm (0.02 \text{ V} + 2.5 \% \text{ of the measured value})$

5.6.2 RINT X12 robot interface

The standard digital interface for mechanised applications^{SEP}

Functions and signals:

- Digital inputs: start/stop, operating modes, JOB and program selection, inching, gas test
- Analogue inputs: control voltages, e.g. for welding performance, welding current, etc.
- Relay outputs: process signal, ready for welding, system composite fault, etc.

5.6.3 BUSINT X11 industrial bus interface

The solution for easy integration with automated production with e.g.

- Profinet/Profibus
- EnthernetIP/DeviceNet
- EtherCAT

etc.

5.7 PC interface



Equipment damage or faults may occur if the PC is connected incorrectly!

Not using the SECINT X10USB interface results in equipment damage or faults in signal transmission. The PC may be destroyed due to high frequency ignition pulses.

- **Interface SECINT X10USB must be connected between the PC and the welding machine!**
- **The connection must only be made using the cables supplied (do not use any additional extension cables)!**

PC300.Net welding parameter software

Set all welding parameters on the PC and simply transfer to one or more welding machines (accessory, set consisting of software, interface, connection leads)

- Manage up to 510 JOBS
- Exchange JOBS with the welding machine
- Online data communication
- Default settings for welding data monitoring
- Always up-to-date thanks to standard update function for new welding parameters
- Data backup by easy communication between power source and PC

5.7.1 Connection

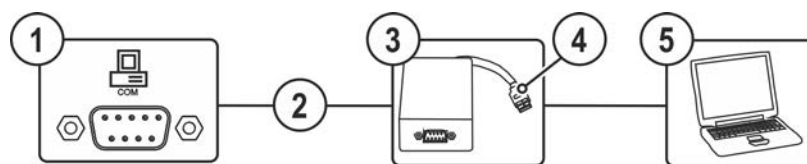

Figure 5-18

Item	Symbol	Description
1		Connection socket (9-pole) - D-Sub PC interface
2		Connection cable, 9-pole, serial
3		SECINT X10 USB
4		USB connection Connecting a Windows PC to SECINT X10 USB
5		Windows PC

5.8 Component identification

These accessory components can be retrofitted as an option > see 9 chapter.

Bar codes predefined in ewm Xnet are recorded with a manual scanner. Component data are retrieved and displayed in the control.

5.9 Network connection

This accessory component is only available as a “factory-fit option”.

The network connection allows the integration of the product into an existing network and exchanging data using the quality-management software Xnet. Some features of the software:

- Real-time display of the welding parameters
- Recording / documentation
- Monitoring of welding parameters
- Maintenance
- Calculations
- WPS management
- Welder management
- xButton management
- Component management

The functionality of the software is in constant development (see the documentation for Xnet).

The welding machines are delivered with a fixed, factory-set IP address printed on a sticker attached to the control unit or, for machines, on a sticker below the rating plate.

The gateway and the server / computer must be in the same network or IP address range to allow the configuration of the gateway.

6 Maintenance, care and disposal

6.1 General

WARNING



Incorrect maintenance, testing and repair!

Maintenance, testing and repair of the machine may only be carried out by skilled and qualified personnel. A qualified person is one who, because of his or her training, knowledge and experience, is able to recognise the dangers that can occur while testing welding power sources as well as possible subsequent damage, and who is able to implement the required safety procedures.

Observe the maintenance instructions > see 6.3 chapter.

- In the event that the provisions of one of the below-stated tests are not met, the machine must not be operated again until it has been repaired and a new test has been carried out!

As a rule, contact your specialised dealer, i.e. the supplier of the machine, with respect to all servicing matters. Any return deliveries in the case of warranty claims can be made via your specialised dealer only.



Only use original spare parts to replace any part. When ordering a spare part, always specify the type, serial number and article number of the machine, and the type designation and article number of the spare part.

Under the specified ambient conditions and normal working conditions this machine is essentially maintenance-free and requires just a minimum of care.

Contamination of the machine may impair service life and duty cycle. The cleaning intervals depend on the ambient conditions and the resulting contamination of the machine. The minimum interval is every six months.

6.2 Explanation of icons









Person

	Welder / operator
	Service staff / expert, qualified person

Test

	Visual inspection
	Functional check

Period, interval

	One-shift operation
	Multi-shift operation
	every 8 hours
	Daily
	Weekly
	Monthly
	Every 6 months
	Annually

6.3 Maintenance schedule

Examiner	Type of test	8h	24h	Maintenance step	Repairer
				<p>! Only people certified as inspectors or repairers may carry out the relevant work step due to their training! Non-applicable checkpoints are omitted.</p>	
				<ul style="list-style-type: none"> Check and clean the welding torch. Deposits in the torch can cause short circuits and have a negative impact on the welding result, ultimately causing damage to the welding torch! Check wire drive, welding torches, and liner elements for application-related equipment and setting. Clean the wire feed rolls on a regular basis (depending on the degree of soiling). Replace worn wire feed rolls. Connections of welding current leads (check that they are fitted correctly and secured). Is shielding gas cylinder with gas cylinder securing elements (chain/belt) secured? Strain relief: Are hose packages secured with strain relief? 	
				<ul style="list-style-type: none"> Checking all supply lines and their connections (pipes, hoses, hose packages) for damage or leaks. Checking the welding system for damage to the housing. Transport elements (strap, lifting eyes, handle, wheels, parking brake) corresponding safety elements (if necessary fuse caps) are present and flawless? 	
				<ul style="list-style-type: none"> Cleaning connections of coolant pipes (quick connect coupling, connections) from soil and install protective caps if not used. Gas test solenoid valve opens and closes properly. Checking operating, signalling and indicator lights, protective devices and actuators. 	
				<ul style="list-style-type: none"> Check wire feed roll holder (wire feed rolls must be firmly seated on their holders and must not have any play) Cleaning dirt filter (if applicable) > see 6.3.1 chapter 	
				<ul style="list-style-type: none"> Checking correct mounting of the wire spool. 	
				<ul style="list-style-type: none"> Cleaning the outer surfaces with a damp cloth (no aggressive cleaning agents). 	
				<ul style="list-style-type: none"> Cleaning power source (inverter) > see 6.3.4 chapter 	
				<ul style="list-style-type: none"> Cleaning heat exchanger (torch cooling) > see 6.3.3 chapter 	
				<ul style="list-style-type: none"> Coolant change (welding torch cooling) > see 6.3.2 chapter 	
				<ul style="list-style-type: none"> Periodic inspection and testing > see 6.3.5 chapter 	

6.3.1 Dirt filter

When using a dirt filter, the cooling air throughput is reduced and the duty cycle of the machine is reduced as a result. The duty cycle decreases with the increasing contamination of the filter. The dirt filter must be removed at regular intervals and cleaned by blowing out with compressed air (depending on the level of soiling).

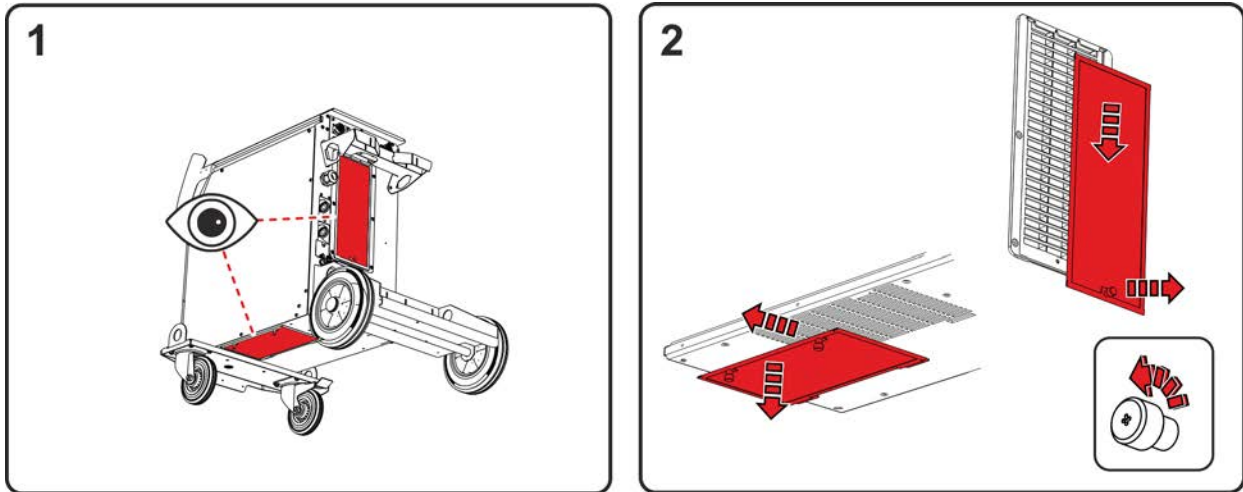

Figure 6-1

- Two dirt filters (option for retrofitting) can be installed on the machine. One at the air inlet of the power unit (inverter) and one at the air inlet of the heat exchanger (torch cooling).
- Loosen the locking screws of the filters (pull the filter of the power unit downwards and then backwards and the filter of the heat exchanger downwards and then to the side).

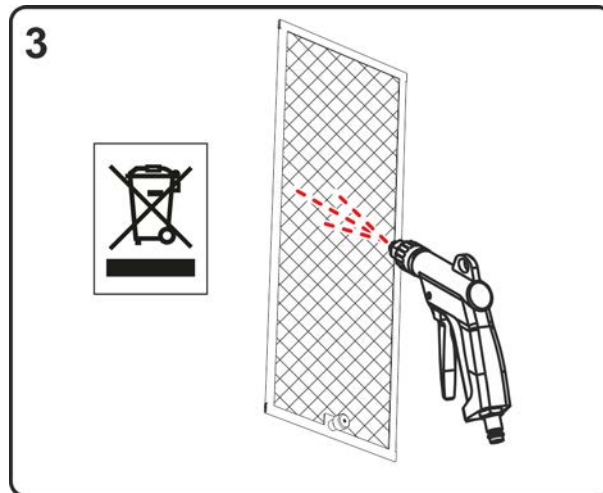

Figure 6-2

- Blow out the dirt filter with compressed air free of oil and water.

Follow official regulations on disposal!

- After cleaning, refit the filters in reverse order.

6.3.2 Coolant error

Observe all instructions for handling, use and disposal of torch coolant > see 5.1.5 chapter.

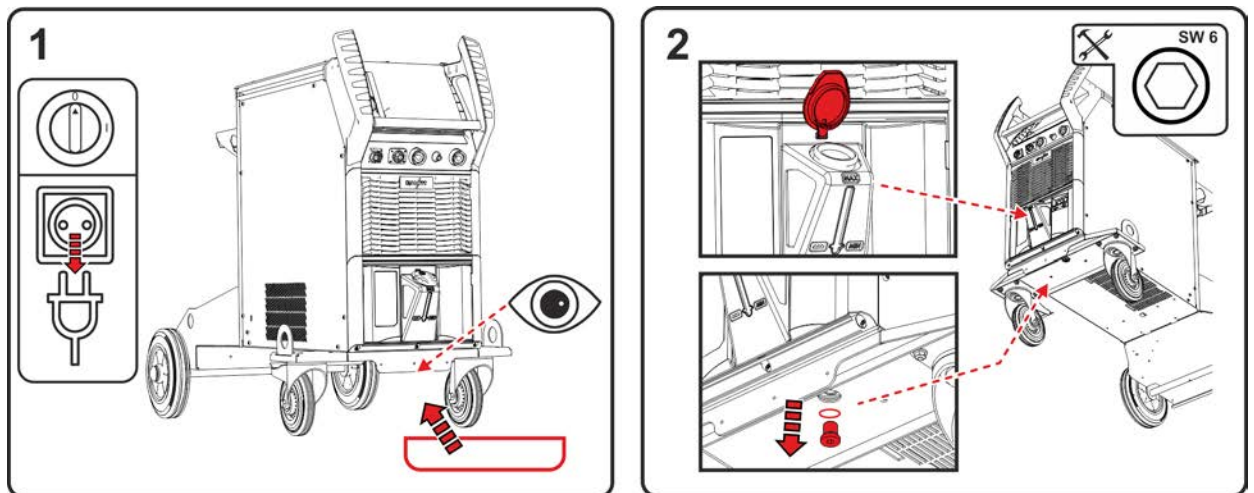

Figure 6-3

- Switch off the machine and disconnect the mains plug. Position a suitable collecting container under the drain plug of the coolant tank.
- Unscrew the drain plug of the coolant tank (remove the tank cap to ventilate).

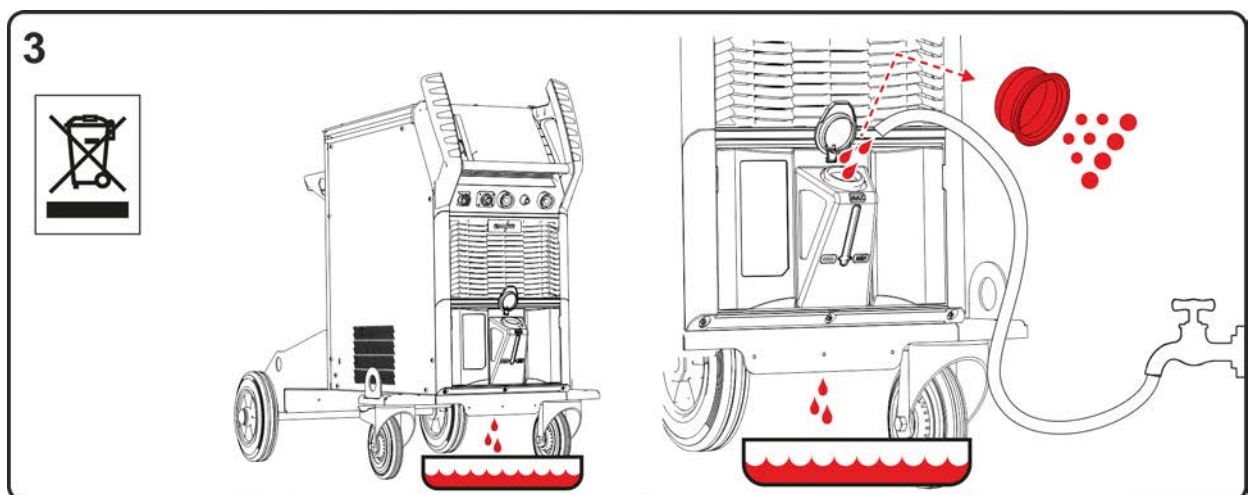

Figure 6-4

- Wait until the coolant has run out of the tank into the collection container.
- Remove the filter screen from the filler neck and clean.
- Then rinse the dirt out of the tank with water.

Follow official regulations on disposal!

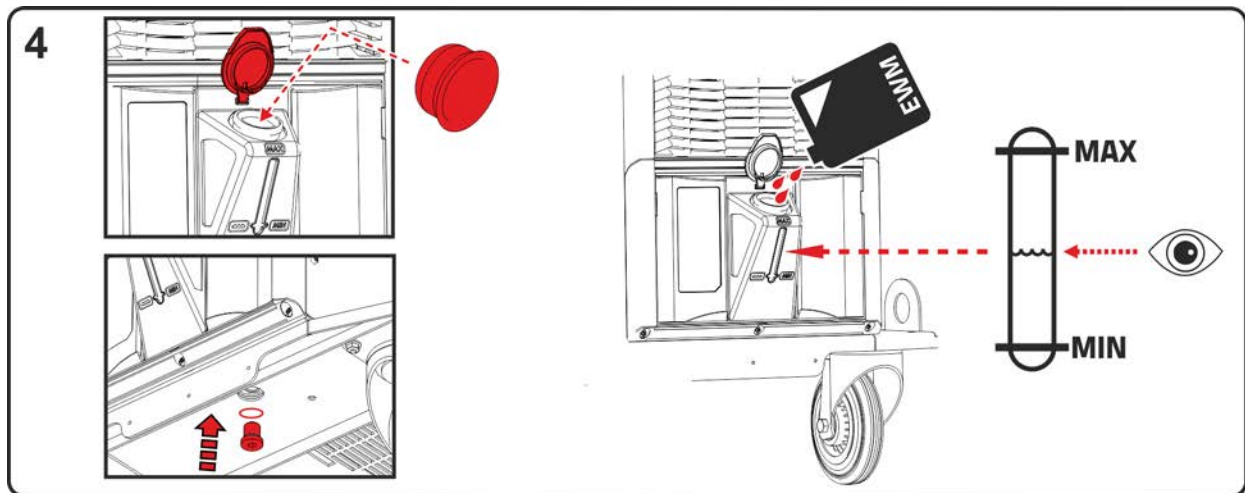

Figure 6-5

- Insert the cleaned filter screen into the filler neck and screw the drain plug with seal back into the tank.
- Fill the tank with original EWM coolant up to the maximum level. After filling, refit the tank cap and vent the coolant circuit > see 7.4 chapter.

6.3.3 Heat exchanger (torch cooling)

⚠ WARNING



Risk of injury due to insufficient training!

An appropriate training is necessary for the following maintenance steps to avoid injuries.

- This maintenance step may only be carried out by trained and authorized specialist staff.
- Observe warnings and maintenance instructions at the beginning of this chapter!

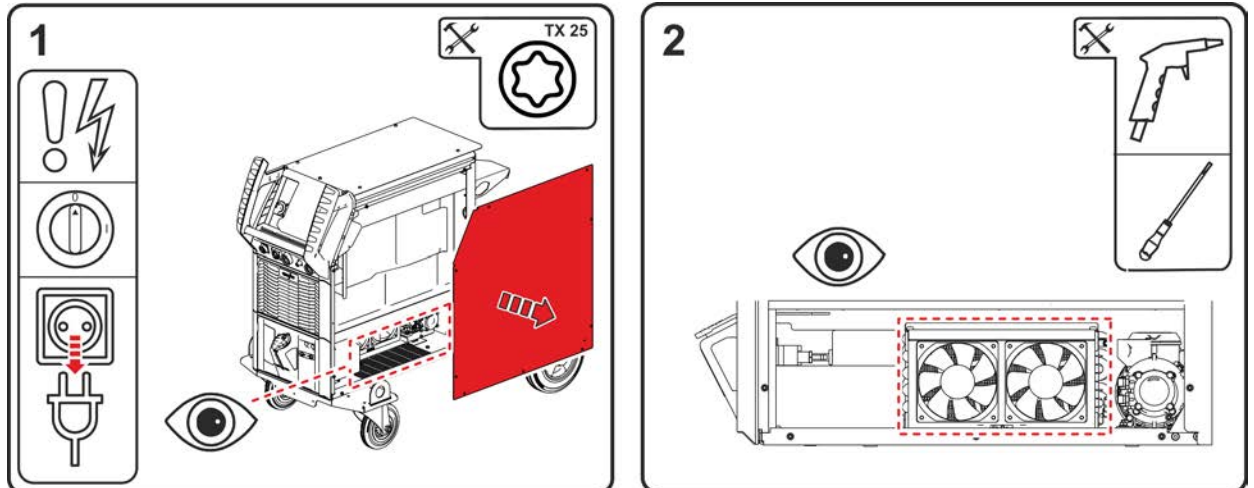

Figure 6-6

- Switch off the machine and disconnect the mains plug. Remove the screws of the side panel. Remove the side panel from the system (lift up and sideways).
- Use only compressed air free of water and oil. Do not blow on electronic components directly. The machine fans may over-rev due to the compressed air and thus become damaged. Therefore, use a screwdriver to block the machine fan mechanically. Please note: The strips of the heat exchanger behind the machine fans must not be damaged by the screwdriver.

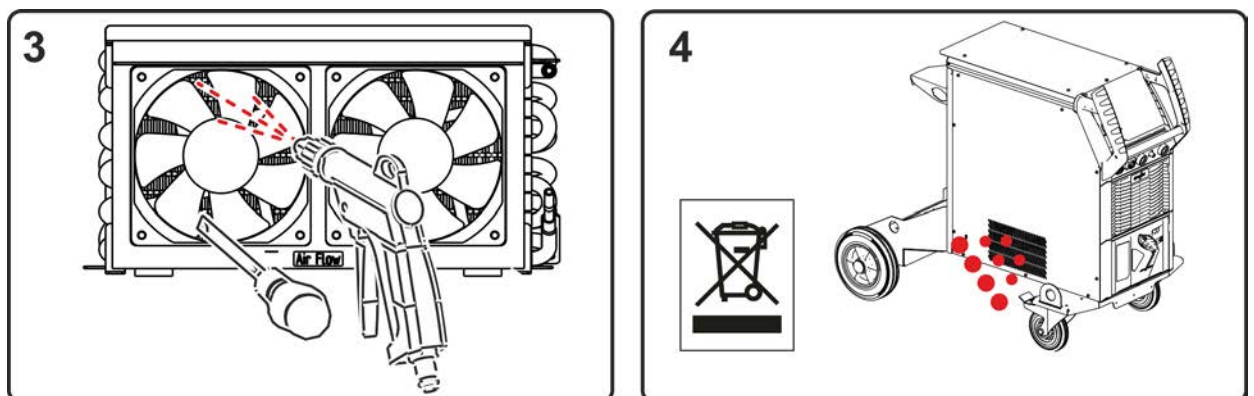

Figure 6-7

- Blow out the heat exchanger using the fans.
- The dirt escapes through the openings in the side panel.

Follow official regulations on disposal!

- After cleaning, remove any mechanical blockages from the fans, close the machine in reverse order and check according to applicable regulations.

6.3.4 Power source (inverter)

⚠ WARNING



Risk of injury due to insufficient training!

An appropriate training is necessary for the following maintenance steps to avoid injuries.

- This maintenance step may only be carried out by trained and authorized specialist staff.
- Observe warnings and maintenance instructions at the beginning of this chapter!

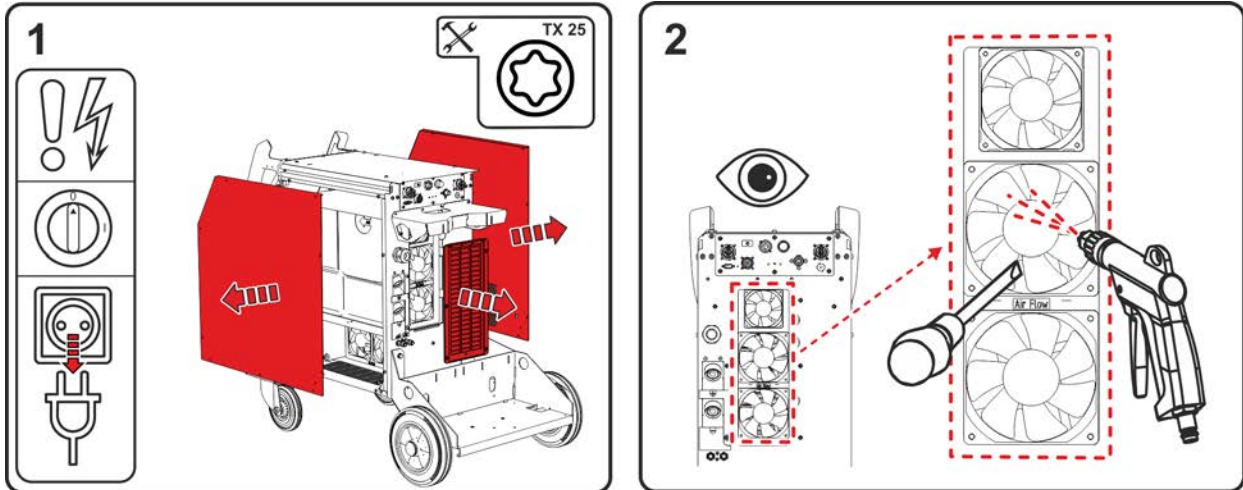

Figure 6-8

- Switch off the machine and disconnect the mains plug. Remove the screws of the side panels and the grille at the rear. Remove side panels (lift up and to the side). Remove louvre (remove downwards and to the back).
- Use only compressed air free of water and oil. Do not blow on electronic components directly. The machine fans may over-rev due to the compressed air and thus become damaged. Therefore, use a screwdriver to block the machine fan mechanically.

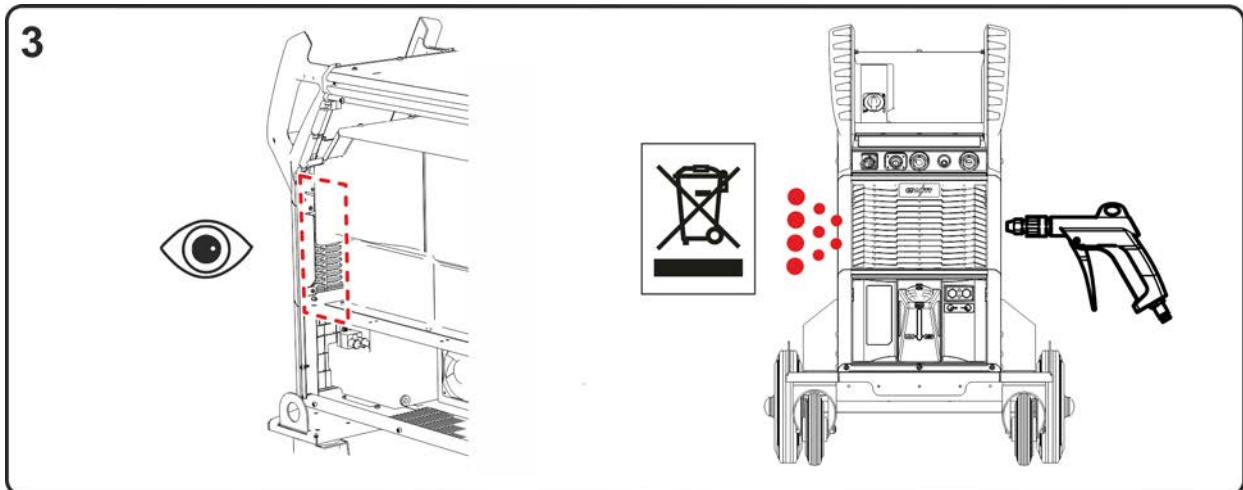

Figure 6-9

- Blow out the areas in front of the inverter from the side.

Follow official regulations on disposal!

- After cleaning, remove any mechanical blockages from the fans, close the machine in reverse order and check according to applicable regulations.

6.3.5 Annual test (inspection and testing during operation)

A periodic test according to IEC 60974-4 "Periodic inspection and test" has to be carried out. In addition to the regulations on testing given here, the relevant local laws and regulations must also be observed.

For more information refer to the "Warranty registration" brochure supplied and our information regarding warranty, maintenance and testing at www.ewm-group.com!

6.4 Disposing of equipment



Proper disposal!

The machine contains valuable raw materials, which should be recycled, and electronic components, which must be disposed of.

- Do not dispose of in household waste!
- Observe the local regulations regarding disposal!
- According to European provisions (Directive 2012/19/EU on Waste of Electrical and Electronic Equipment), used electric and electronic equipment may no longer be placed in unsorted municipal waste. It must be collected separately. The symbol depicting a waste container on wheels indicates that the equipment must be collected separately. This machine has to be disposed of, or recycled, in accordance with the waste separation systems in use.
- According to German law (law governing the distribution, taking back and environmentally correct disposal of electric and electronic equipment (ElektroG)), used machines are to be placed in a collection system separate from unsorted municipal waste. The public waste management utilities (communities) have created collection points at which used equipment from private households can be disposed of free of charge.
- Information about returning used equipment or about collections can be obtained from the respective municipal administration office.
- In addition to this, returns are also possible throughout Europe via EWM sales partners.

7 Rectifying faults

All products are subject to rigorous production checks and final checks. If, despite this, something fails to work at any time, please check the product using the following flowchart. If none of the fault rectification procedures described leads to the correct functioning of the product, please inform your authorised dealer.

7.1 Error messages (power source)

Depending on the options of the machine display, a fault is shown as follows:

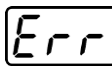
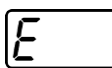
Display type - machine control	Display
Graphic display	
two 7-segment displays	
one 7-segment display	

The possible cause of the fault is signalled by a corresponding fault number (see table). In the case of an error, the power unit shuts down.

The display of possible error numbers depends on the machine version (interfaces/functions).

- Document machine errors and inform service staff as necessary.
- If multiple errors occur, these are displayed in succession.
- Document machine warning and inform service personnel, if required.
- If there are several errors in a control system, the error with the lowest error number (Err) is displayed. If this error is corrected, the next higher error number appears. This process is repeated until all errors have been resolved.

Categories legend (resetting the error)

- The error message will disappear once the error has been rectified.
- The error message can be reset by pressing a push-button ◀.
- The error message can only be reset by switching the machine off and on again.

	Category			Error	Possible cause	Remedy	
	a)	b)	c)				
3	✓	✓	✗	Tacho error	Error of wire feeder	Check connections (connections, pipes)	
					Permanent overload of the wire drive		Do not place the liner in tight radii; check wire core for smooth movement
4	✓	✗	✗	Excess temperature	Power source overheated	Allow the power source to cool down (mains switch to "1")	
					Fan blocked, dirty or defective		Check fan and clean or replace
					Air inlet or outlet blocked		Check air inlet and outlet
5	✗	✗	✓	Mains overvoltage	Mains voltage is too high	Check the mains voltages and compare with the power source connection voltages	
6	✗	✗	✓	Mains undervoltage	Mains voltage is too low		
7	✗	✓	✗	Low coolant level	Flow rate too low (< = 0.7 l/min) / (< = 0.18 gal/min) ^{[1][3]}	Check coolant flow, clean water block, remove kinks in hose package, adjust flow threshold	
					Coolant volume too low		Fill coolant
					Pump does not run		Turn the pump shaft

Err	Category			Error	Possible cause	Remedy
	a)	b)	c)			
					Air in the coolant circuit	Vent coolant circuit
					Hose package not completely filled with coolant	Switch machine off / on (pump runs for 2 min)
					Operation with gas-cooled welding torch	Connect coolant feed and coolant return (insert hose bridge); deactivate water block
					Failure of automatic circuit-breaker ^[4]	Press to reset automatic circuit-breaker
8	✓	✓	✗	Shielding gas error ^[2]	No shielding gas Pre-pressure too low	Check shielding gas supply Remove kinks in the hose package; nominal value: 4-6 bar primary pressure
9	✗	✗	✓	Sec. overvoltage	Overvoltage at output: Inverter error	Inform Service
10	✗	✗	✓	Earth fault (PE error)	Connection between welding wire and machine casing	Remove electrical connection
11	✓	✓	✗	Quick shut-down	Removing the logical signal "robot ready" during the process	Eliminate errors on the higher-level control
22	✓	✗	✗	Coolant excess temperature ^[3]	Coolant is overheating ($\geq 70^{\circ}\text{C}$ / $\geq 158^{\circ}\text{F}$) ^[1] measured in the coolant return line	Allow the power source to cool down (mains switch to "1")
					Fan blocked, dirty or defective	Check fan, clean or replace
					Air inlet or outlet blocked	Check air inlet and outlet
32	✗	✗	✓	Error I>0 ^[3]		Inform Service
33	✗	✗	✓	Error UIST ^[3]	Short circuit in welding circuit before welding	Eliminate short circuit in welding circuit; remove external sensor voltage
38	✗	✗	✓	Error IIST ^[3]	Short circuit in welding circuit before welding	Eliminate short circuit in welding circuit
48	✗	✓	✗	Ignition error	No ignition occurred during a process start with automated machines	Check the wire feeding, check the connections of the load cables in the welding circuit, clean corroded surfaces on the workpiece before welding if applicable
49	✗	✓	✗	Arc interruption	An arc interruption occurred during welding with an automated system	Check wire feeding; adjust welding speed.
51	✓	✗	✗	Emergency stop	The emergency stop circuit of the power source has been activated.	Disable the activation of the emergency stop circuit (release protective circuit)
52	✗	✗	✓	No wire feeder	After switching on the automated system, no wire feeder was detected	Check or connect control cables of wire feeders; check the identification number of the automated wire feeder (for 1DV: number 1, for 2DV: each a wire feeder with number 1 and a wire feeder with number 2)
53	✗	✓	✗	No wire feeder 2	Wire feeder 2 not detected	Check or connect the control lines of the wire feeders

Rectifying faults

Error messages (power source)



Err	Category			Error	Possible cause	Remedy
	a)	b)	c)			
54	✗	✗	✓	VRD error ^[2]	Open circuit voltage reduction error	if necessary, disconnect external machine from the welding circuit; inform Service
55	✗	✓	✗	WF excess current	Overcurrent detection on wire feeder	Do not place the liner in tight radii; check wire core for smooth movement
56	✗	✗	✓	Mains phase failure	One phase of the mains voltage has failed	Check mains connection, mains plug and mains fuses
57	✗	✓	✗	Slave tacho error	Wire feeder fault (slave drive)	Check connectors, cables, connections
				Permanent overload of the wire drive (slave drive)	Do not place the liner in tight radii; check wire core for smooth movement	
58	✗	✓	✗	Short circuit	Check welding circuit for short circuit	Check welding circuit; isolate welding torch before depositing
59	✗	✗	✓	Incompatible machine	A machine connected to the system is not compatible	Please disconnect the incompatible machine from the system
60	✗	✗	✓	Incompatible software	A machine's software is not compatible.	Inform Service
61	✗	✓	✗	Welding monitor	The actual value of a welding parameter is outside the specified tolerance field	Observe tolerance fields; adjust welding parameters
62	✗	✗	✓	System component ^[3]	System component not found	Inform Service

^[1] factory setting

^[2] option

^[3] only machine series Titan XQ, Phoenix XQ, Taurus XQ

^[4] not machine series Titan XQ, Phoenix XQ, Taurus XQ

7.2 Warnings

Depending on the display options of the machine display, a warning message is displayed as follows:

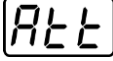
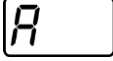
Display type - machine control	Display
Graphic display	
two 7-segment displays	
one 7-segment display	

The cause of the warning is indicated by a corresponding warning number (see table).

- In case of multiple warnings, these are displayed in sequence.
- Document machine warning and inform service personnel, if required.

No.	Warning	Possible cause
1	Excess temperature	A shutdown is imminent due to excess temperature.
4	Shielding gas ^[2]	Check shielding gas supply.
5	Coolant flow ^[3]	Flow rate ($\leq 0.7\text{l/min}$ / $\leq 0.18\text{ gal./min}$) ^[1]
6	low wire	Only a small amount of wire is left on the spool.
7	CAN bus failure	Wire feeder not connected, automatic circuit-breaker of wire feed motor (reset the tripped automatic circuit-breaker by actuating).
8	Welding circuit	The welding circuit inductance is too high for the selected welding task.
10	Partial inverter	One of several partial inverters is not supplying welding current.
11	Excess temperature, coolant ^[3]	Coolant ($\geq 65^\circ\text{C}$ / $\geq 149^\circ\text{F}$) ^[1]
12	Welding monitor	The actual value of a welding parameter is outside the specified tolerance field.
13	Contact error	The resistance in the welding circuit is too high. Check earth connection.
32	Tacho error	Fault of wire feeder, permanent overload of the wire drive.
33	WF excess current	Overcurrent detection of the main WF drive.
34	JOB unknown	JOB selection was not performed because the JOB number is unknown.
35	WF excess current slave	Overload of the slave WF drive (front drive push/push system or intermediate drive).
36	Slave tacho error	Fault of wire feeder, permanent overload of the slave WF drive (front drive push/push system or intermediate drive).
37	FST bus failure	Wire feeder not connected, automatic circuit-breaker of wire feed motor (reset the tripped automatic circuit-breaker by actuating).

^[1] factory setting

^[2] option

^[3] only machine series Titan XQ, Phoenix XQ, Taurus XQ

7.3 Checklist for rectifying faults

The correct machine equipment for the material and process gas in use is a fundamental requirement for perfect operation!

Legend	Symbol	Description
	↗	Fault/Cause
	✘	Remedy

Functional errors

- ↗ Mains fuse triggers - unsuitable mains fuse
 - ✘ Set up recommended mains fuse > see 8 chapter.
- ↗ Machine does not start up after switching on (device fan and possibly coolant pump have no function).
 - ✘ Connect the control cable of the wire feeder.
- ↗ All machine control signal lights are illuminated after switching on
- ↗ No machine control signal light is illuminated after switching on
- ↗ No welding power
 - ✘ Phase failure > check mains connection (fuses)
- ↗ Machine restarts continuously
- ↗ Wire feeder without function
- ↗ System does not start up
 - ✘ Make control lead connections and check that they are fitted correctly.
- ↗ Loose welding current connections
 - ✘ Tighten power connections on the torch and/or on the workpiece
 - ✘ Properly fasten the contact tip and contact tip holder.

Collective interference signal light illuminates

- ↗ Excess temperature, welding machine
 - ✘ Allow the machine to cool down whilst still switched on
- ↗ Welding current monitoring device triggered (stray welding currents flowing across the protective earth). The error must be reset by switching the machine off and on again.
 - ✘ Welding wire is touching electrically conductive casing parts (check wire guide, has the welding wire sprung off the wire spool?).
 - ✘ Check for a correct mounting of the welding lead. Fit the feeder clamp of the welding lead as close as possible to the arc.

Excess temperature signal light illuminates

- ↗ Excess temperature, welding machine
 - ✘ Allow the machine to cool down whilst still switched on

Coolant error/no coolant flowing

- ↗ Insufficient coolant flow
 - ✘ Check coolant level and refill if necessary
- ↗ Air in the coolant circuit
 - ✘ Vent coolant circuit > see 7.4 chapter

Wire feed problems

- ✓ Wire feed roll holder is worn (wire feed rolls must be firmly seated on their holders and must not have any play)
 - ✘ Replace wire feed roll holder (092-002960-E0000)
- ✓ Contact tip blocked
 - ✘ Clean, spray with anti-spatter spray and replace if necessary
- ✓ Setting the spool brake
 - ✘ Check settings and correct if necessary
- ✓ Setting pressure units
 - ✘ Check settings and correct if necessary
- ✓ Worn wire rolls
 - ✘ Check and replace if necessary
- ✓ Wire feed motor without supply voltage (automatic cutout triggered by overloading)
 - ✘ Reset triggered fuse (rear of the power source) by pressing the key button
- ✓ Kinked hose packages
 - ✘ Extend and lay out the torch hose package
- ✓ Wire guide core or spiral is dirty or worn
 - ✘ Clean core or spiral; replace kinked or worn cores

7.4 Vent coolant circuit

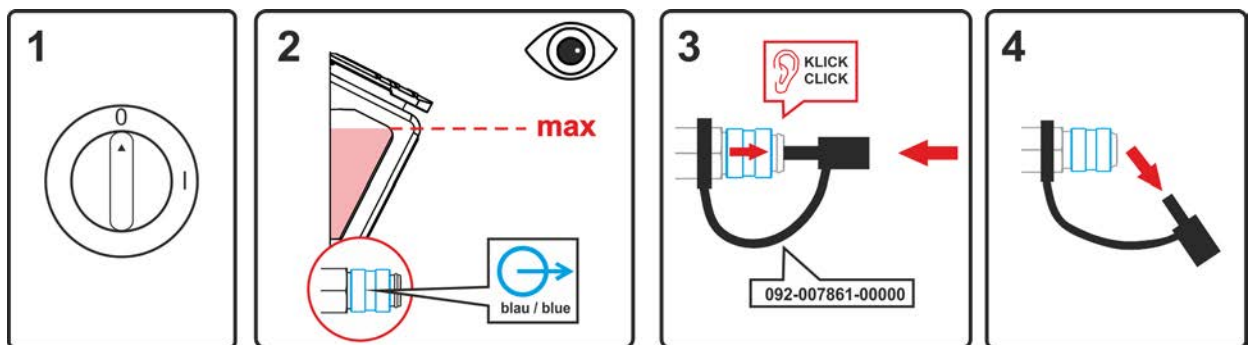

Figure 7-1

- Switch off the machine and fill the coolant tank to the maximum level.
- Unlock the quick-connect coupling with a suitable tool (connection open).

To vent the cooling system always use the blue coolant connection, which is located as deep as possible inside the system (close to the coolant tank)!

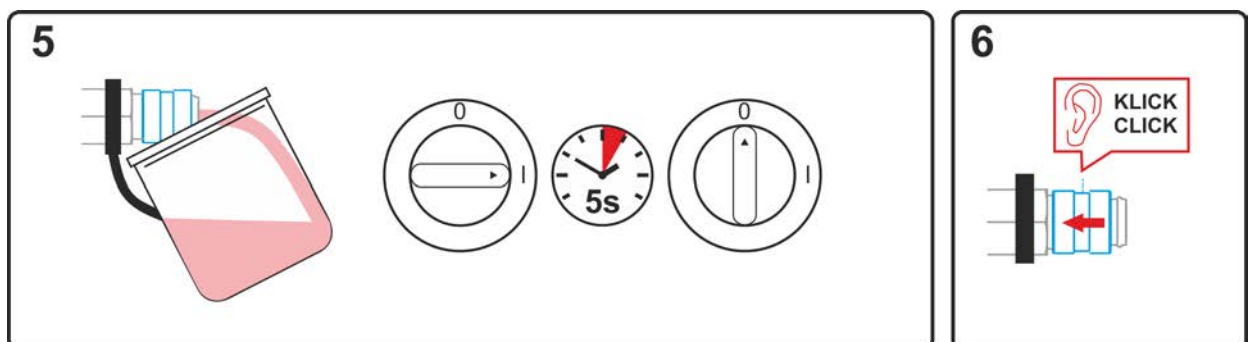

Figure 7-2

- Position a suitable collection container for collecting the escaping coolant at the quick-connect coupling and switch on the machine for approx. 5s.
- Lock the quick-connect coupling by pushing back the locking ring.

7.5 Fixing the pump shaft (coolant circuit)

Continuing non-use and impurities in the coolant may result in the the coolant pump not being in proper working order.

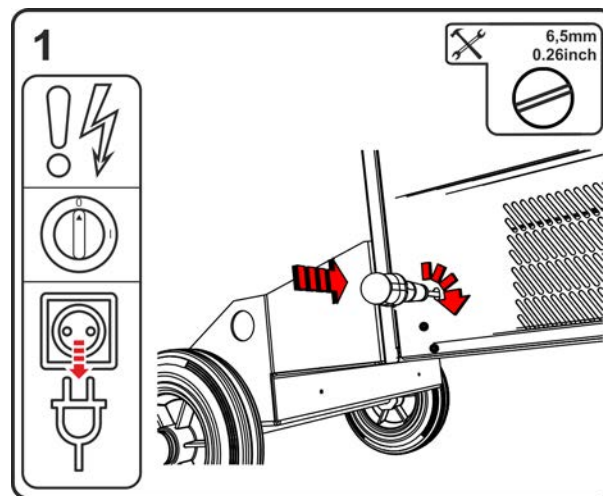

Figure 7-3

- Switch off machine at the main switch.
- Disconnect mains plug.
- Insert a plain slot screwdriver with a maximum tip width of 6.5 mm through the maintenance opening and place in the centre of the pump shaft. Turn the screwdriver clockwise until the pump shaft can be easily rotated again.
- Remove screwdriver.
- Insert mains plug of the switched-off machine into the appropriate socket.
- Switch on the power source at the main switch.

8 Technical data

Performance specifications and guarantee only in connection with original spare and replacement parts!

8.1 Dimensions and weights

		F06R1/R2		F06RS		F06P	
Dimensions (l x b x h)		mm	inch	mm	inch	mm	inch
l		1152	45.3	854	33.6	854	33.6
b		686	27.0	590	23.2	400	15.7
h		976	38.4	976	38.4	881	34.7
Weight ^[1]		kg	lb.	kg	lb.	kg	lb.
F06G		113,9	251.1	103,7	228.6	88,7	195,5
F06W		128,5	283.2	118,3	260.8	103,3	227,7
F06WRF		132,5	292.1	122,3	269,6	107,3	236.5

^[1] All weights refer to 5 m (16.4 ft.) machine versions Mains connection cable. For versions with longer mains connection cables, the weights increase.

10 m (32.8 ft.) = +2.5 kg (5.5 lb.)

15 m (49.2 ft.) = +5.0 kg (11.0 lb.)

8.2 Welding torch cooling system

Torch cooling	F06W	F06WRF
Cooling capacity at 1 l/min (+25°C/77°F)	1.5 KW	
Max. flow rate	5 l/min 1.3 gal./min	20 l/min 5.2 gal./min
max. delivery height	35 m 115 ft.	45 m 148 ft.
Max. pump pressure	3.5 bar 0.35 MPa	4.5 bar 0.45 MPa
Pump	Centrifugal pump	
Max. tank capacity	8 l 2.1 gal.	
Flow monitoring		
Error limit	0.7 l/min 0.18 gal./min	
Warning limit	Error limit +0.3 l/min Error limit +0.08 gal./min	
Temperature monitoring		
Error limit	70°C 158°F	
Warning limit	Error limit -5°C Error limit -23°F	

8.3 Performance data

8.3.1 Titan XQ 350 puls D

	MIG/MAG	MMA	TIG
Welding current (I_2)	5 A to 350 A		
Welding voltage according to standard (U_2)	14,3 V to 31,5 V	20,2 V to 34,0 V	10,2 V to 24,0 V
Duty cycle DC at 40° C ^[1]	350 A (100%)		
Mains voltage ^[2]	3 x 380-400 V / 3 x 440-460 V / 3 x 480-500 V		
Frequency	50/60 Hz		
Tolerance / mains fuse ^[3]			
380-400 V	-25 % to +20 % / 3 x 25 A		
440-460 V	-25 % to +15 % / 3 x 20 A		
460-500 V	-25 % to +10 % / 3 x 20 A		
Open circuit voltage (U_0)	82 V (380-400 V) 94 V (440-460 V) 102 V (460-500 V)		
max. Connected load (S_1)			
gas cooled (F06G)	14,3 kVA	15,4 kVA	10,9 kVA
water cooled (F06W)	14,7 kVA		11,3 kVA
water cooled, Reinforced (F06WRF)	14,9 kVA		11,5 kVA
Generator rating (Rec.)	21 kVA		
Power consumption P_0 ^[4]	25 W		
Maximum mains impedance (@PCC) ^[5]	107 mOhm		
Cos ϕ / efficiency	0,99 / 88 %		
Protection class / Overvoltage category	I / III		
Contamination level / Insulation class	3 / H		
protection classification / Residual current circuit breaker	IP 23 / Type B (recommended)		
Noise level ^[6]	<70 dB(A)		
Ambient temperature ^[7]	-25 °C to +40 °C		
Machine cooling / Torch cooling	Fan (AF) / gas or water		
Mains connection cable	H07RN-F4G6		
Workpiece lead (min.) / EMC class	70 mm ² / A		
Safety marking	☐ / CE / ENEC		
Standards used	See declaration of conformity (appliance documents)		

^[1] Load cycle: 10 min. (60 % DC \pm 6 min. welding, 4 min. pause)

^[2] Multi-voltage device - Adjusting the power source to the mains voltage

^[3] Safety fuses are recommended DIAZED xxA gG. When using automatic cutouts, the "C" trigger characteristic must be used.

^[4] Power in idle mode without wire feeder.

^[5] This welding equipment does not comply with IEC 61000-3-12. When connecting a welding machine to a public low-voltage supply system, the manufacturer or operator has to consult the electricity utilities to make sure the welding machine may be connected.

^[6] Noise level during idle mode and operation under standard load according to IEC 60974- 1 at the maximum operating point.

^[7] Ambient temperature dependent on coolant! Observe coolant temperature range!

8.3.2 Titan XQ 400 puls D

	MIG/MAG	MMA	TIG
Welding current (I ₂)	5 A to 400 A		
Welding voltage according to standard (U ₂)	14,3 V to 34 V	20,2 V to 36,0 V	10,2 V to 26,0 V
Duty cycle DC at 40° C ^[1]	400 A (80 %) / 370 A (100%)		
Mains voltage ^[2]	3 x 380-400 V / 3 x 440-460 V / 3 x 480-500 V		
Frequency	50/60 Hz		
Tolerance / mains fuse ^[3]			
380-400 V	-25 % to +20 % / 3 x 25 A		
440-460 V	-25 % to +15 % / 3 x 25 A		
460-500 V	-25 % to +10 % / 3 x 20 A		
Open circuit voltage (U ₀)	82 V (380-400 V) 94 V (440-460 V) 102 V (460-500 V)		
max. Connected load (S ₁)			
gas cooled (F06G)	17,6 kVA	18,6 kVA	13,5 kVA
water cooled (F06W)	18,0 kVA		13,9 kVA
water cooled, Reinforced (F06WRF)	18,2 kVA		14,1 kVA
Generator rating (Rec.)	25 kVA		
Power consumption P ₀ ^[4]	25 W		
Maximum mains impedance (@PCC) ^[5]	120 mOhm		
Cos φ / efficiency	0,99 / 88 %		
Protection class / Overvoltage category	I / III		
Contamination level / Insulation class	3 / H		
protection classification / Residual current circuit breaker	IP 23 / Type B (recommended)		
Noise level ^[6]	<70 dB(A)		
Ambient temperature ^[7]	-25 °C to +40 °C		
Machine cooling / Torch cooling	Fan (AF) / gas or water		
Mains connection cable	H07RN-F4G6		
Workpiece lead (min.) / EMC class	70 mm ² / A		
Safety marking	☐ / CE / EMC		
Standards used	See declaration of conformity (appliance documents)		

^[1] Load cycle: 10 min. (60 % DC \triangleq 6 min. welding, 4 min. pause)

^[2] Multi-voltage device - Adjusting the power source to the mains voltage

^[3] Safety fuses are recommended DIAZED xxA gG. When using automatic cutouts, the "C" trigger characteristic must be used.

^[4] Power in idle mode without wire feeder.

^[5] This welding equipment does not comply with IEC 61000-3-12. When connecting a welding machine to a public low-voltage supply system, the manufacturer or operator has to consult the electricity utilities to make sure the welding machine may be connected.

^[6] Noise level during idle mode and operation under standard load according to IEC 60974- 1 at the maximum operating point.

^[7] Ambient temperature dependent on coolant! Observe coolant temperature range!

8.3.3 Titan XQ 500 puls D

	MIG/MAG	MMA	TIG
Welding current (I_2)	5 A to 500 A		
Welding voltage according to standard (U_2)	14,3 V to 39,0 V	20,2 V to 40,0 V	10,2 V to 30,0 V
Duty cycle DC at 40° C ^[1]	500 A (80 %) / 470 A (100%)		
Mains voltage ^[2]	3 x 380-400 V / 3 x 440-460 V / 3 x 480-500 V		
Frequency	50/60 Hz		
Tolerance / mains fuse ^[3]			
380-400 V	-25 % to +20 % / 3 x 35 A		
440-460 V	-25 % to +15 % / 3 x 32 A		
460-500 V	-25 % to +10 % / 3 x 32 A		
Open circuit voltage (U_0)	82 V (380-400 V) 94 V (440-460 V) 102 V (460-500 V)		
max. Connected load (S_1)			
gas cooled (F06G)	25,2 kVA	25,8 kVA	19,4 kVA
water cooled (F06W)	25,6 kVA		19,8 kVA
water cooled, Reinforced (F06WRF)	25,8 kVA		20,0 kVA
Generator rating (Rec.)	35 kVA		
Power consumption P_0 ^[4]	27 W		
Maximum mains impedance (@PCC) ^[5]	80 mOhm		
Cos ϕ / efficiency	0,99 / 88 %		
Protection class / Overvoltage category	I / III		
Contamination level / Insulation class	3 / H		
protection classification / Residual current circuit breaker	IP 23 / Type B (recommended)		
Noise level ^[6]	<70 dB(A)		
Ambient temperature ^[7]	-25 °C to +40 °C		
Machine cooling / Torch cooling	Fan (AF) / gas or water		
Mains connection cable	H07RN-F4G6		
Workpiece lead (min.) / EMC class	95 mm ² / A		
Safety marking	[S] / CE / EAC		
Standards used	See declaration of conformity (appliance documents)		

^[1] Load cycle: 10 min. (60 % DC \triangleq 6 min. welding, 4 min. pause)

^[2] Multi-voltage device - Adjusting the power source to the mains voltage

^[3] Safety fuses are recommended DIAZED xxA gG. When using automatic cutouts, the "C" trigger characteristic must be used.

^[4] Power in idle mode without wire feeder.

^[5] This welding equipment does not comply with IEC 61000-3-12. When connecting a welding machine to a public low-voltage supply system, the manufacturer or operator has to consult the electricity utilities to make sure the welding machine may be connected.

^[6] Noise level during idle mode and operation under standard load according to IEC 60974- 1 at the maximum operating point.

^[7] Ambient temperature dependent on coolant! Observe coolant temperature range!

8.3.4 Titan XQ 600 puls D

	MIG/MAG	MMA	TIG
Welding current (I ₂)	5 A to 600 A		
Welding voltage according to standard (U ₂)	14,3 V to 44,0 V	20,2 V to 44,0 V	10,2 V to 34,0 V
Duty cycle DC at 40° C ^[1]	600 A (40 %) / 550 A (60 %) / 470 A (100%)		
Mains voltage ^[2]	3 x 380-400 V / 3 x 440-460 V / 3 x 480-500 V		
Frequency	50/60 Hz		
Tolerance / mains fuse ^[3]			
380-400 V	-25 % to +20 % / 3 x 35 A		
440-460 V	-25 % to +15 % / 3 x 32 A		
460-500 V	-25 % to +10 % / 3 x 32 A		
Open circuit voltage (U ₀)	82 V (380-400 V) 94 V (440-460 V) 102 V (460-500 V)		
max. Connected load (S ₁)			
gas cooled (F06G)	34,1 kVA	34,1 kVA	25,4 kVA
water cooled (F06W)	34,5 kVA		26,8 kVA
water cooled, Reinforced (F06WRF)	34,7 kVA		27,0 kVA
Generator rating (Rec.)	47 kVA		
Power consumption P ₀ ^[4]	27 W		
Maximum mains impedance (@PCC) ^[5]	75 mOhm		
Cos φ / efficiency	0,99 / 88 %		
Protection class / Overvoltage category	I / III		
Contamination level / Insulation class	3 / H		
protection classification / Residual current circuit breaker	IP 23 / Type B (recommended)		
Noise level ^[6]	<70 dB(A)		
Ambient temperature ^[7]	-25 °C to +40 °C		
Machine cooling / Torch cooling	Fan (AF) / gas or water		
Mains connection cable	H07RN-F4G6		
Workpiece lead (min.) / EMC class	95 mm ² / A		
Safety marking	☐ / CE / EMC		
Standards used	See declaration of conformity (appliance documents)		

^[1] Load cycle: 10 min. (60 % DC \triangleq 6 min. welding, 4 min. pause)

^[2] Multi-voltage device - Adjusting the power source to the mains voltage

^[3] Safety fuses are recommended DIAZED xxA gG. When using automatic cutouts, the "C" trigger characteristic must be used.

^[4] Power in idle mode without wire feeder.

^[5] This welding equipment does not comply with IEC 61000-3-12. When connecting a welding machine to a public low-voltage supply system, the manufacturer or operator has to consult the electricity utilities to make sure the welding machine may be connected.

^[6] Noise level during idle mode and operation under standard load according to IEC 60974- 1 at the maximum operating point.

^[7] Ambient temperature dependent on coolant! Observe coolant temperature range!

9 Accessories

Performance-dependent accessories like torches, workpiece leads, electrode holders or intermediate hose packages are available from your authorised dealer.

9.1 General accessories

Type	Designation	Item no.
KLF-L1-L2-L3-PE	Label of mains cable	094-023697-00000
DM 842 Ar/CO2 230bar 30l D	Pressure regulator with manometer	394-002910-00030
32A 5POLE/CEE	Machine plug	094-000207-00000

9.2 7-pole remote control

Type	Designation	Item no.
RC XQ Expert 2.0 2 m	Expert XQ 2.0 remote control	090-008824-00002
RC XQ Expert 2.0 5 m	Expert XQ 2.0 remote control	090-008824-00005
RC XQ Expert 2.0 10 m	Expert XQ 2.0 remote control	090-008824-00010
RC XQ Expert 2.0 15 m	Expert XQ 2.0 remote control	090-008824-00015

9.2.1 Extension cable

Type	Designation	Item no.
FRV 7POL 0.5 m	Extension/connecting cable	092-000201-00004
FRV 7POL 1 m	Extension/connecting cable	092-000201-00002
FRV 7POL 5 m	Extension/connecting cable	092-000201-00003
FRV 7POL 10 m	Extension/connecting cable	092-000201-00000
FRV 7POL 15M	Extension/connecting cable	092-000201-00005
FRV 7POL 20 m	Extension/connecting cable	092-000201-00001
FRV 7POL 25M	Extension/connecting cable	092-000201-00007

9.3 19-pole remote control

Type	Designation	Item no.
R10 19POL	Remote control	090-008087-00000
RG10 19POL 5M	Remote control to set the wire speed and welding voltage correction	090-008108-00000
R20 19POL	Program changeover remote control	090-008263-00000

9.3.1 Connection cables

Type	Designation	Item no.
RA5 19POL 5M	Remote control e.g. connection cable	092-001470-00005
RA10 19POL 10m	Remote control e.g. connection cable	092-001470-00010
RA20 19POL 20m	Remote control e.g. connection cable	092-001470-00020

9.3.2 Extension cable

Type	Designation	Item no.
RV5M19 19POLE 5M	Extension cable	092-000857-00000
RV5M19 19POL 10M	Extension cable	092-000857-00010
RV5M19 19POL 15M	Extension cable	092-000857-00015
RV5M19 19POL 20M	Extension cable	092-000857-00020

9.4 Options

Type	Designation	Item no.
ON PS F06 1D01	Pivot support for a wire feeder	092-003330-00000
ON PS F06 1D02	Pivot support for an IC wire feeder	092-003332-00000
ON PS F06 2D01	Transport support for two wire feeders	092-003331-00000
ON PS EXT D01	Retrofit set: Extension turning mandrel, for holding a wire feeder with wheel kit ON WAK D01	092-002871-00000
ON Shock Protect F06	Ram protection	092-003334-00000
ON Filter F06	Dirt filter for air inlet	092-003337-00000
ON HS F06	Holder for holding long hose packages and welding torch	092-003333-00000
ON TS F06 R	Torch holder, right	092-003335-00000
ON TS F06 L	Torch holder, left	092-003360-00000
ON SH F06 L	Scanner holder, left	092-003434-00000
OU F06W	Conversion kit, water block	092-003492-00000
OU F06WRF	Conversion kit, water block with reinforced pump	092-003493-00000
OU F06R1/R2	Conversion kit, single cylinder holder to double cylinder holder	092-003494-00000
OU Expert XQ 2.0	Conversion kit, Expert XQ 2.0	092-003495-00000
OU Expert XQ 2.0 WLG	Conversion kit, Expert XQ 2.0 with LAN/Wi-Fi gateway including interface for barcode scanner	092-003496-00000
OU 2DV	Conversion kit for two wire feeders	092-003497-00000
OU AIF F06	Conversion kit, 19-pole interface for automated welding	092-003498-00000

9.5 Computer communication

Type	Designation	Item no.
PC300 XQ Set	PC300.Net welding parameter software kit incl. cable and SECINT X10 USB interface	090-008777-00000
ON WLG-EX	Wi-Fi gateway in external casing	090-008790-00502
ON LG-EX	LAN gateway in external casing	090-008789-00502

9.6 Welding torch cooling system

Type	Designation	Item no.
HOSE BRIDGE UNI	Tube bridge	092-007843-00000

9.6.1 Coolant - type blueCool

Type	Designation	Item no.
blueCool -10 5 l	Coolant up to -10 °C (14 °F), 5 l	094-024141-00005
blueCool -10 25 l	Coolant up to -10 °C (14 °F), 25 l	094-024141-00025
blueCool -30 5 l	Coolant up to -30 °C (22 °F), 5 l	094-024142-00005
blueCool -30 25 l	Coolant up to -30 °C (22 °F), 25 l	094-024142-00025
FSP blueCool	Frost protection tester	094-026477-00000

9.6.2 Coolant - type KF

Type	Designation	Item no.
KF 23E-5	Coolant up to -10 °C (14 °F), 5 l	094-000530-00005
KF 23E-200	Coolant (-10 °C), 200 litres	094-000530-00001
KF 37E-5	Coolant up to -20 °C (4 °F), 5 l	094-006256-00005
KF 37E-200	Coolant (-20 °C), 200 l	094-006256-00001
TYP1	Frost protection tester	094-014499-00000

10 Appendix

10.1 Searching for a dealer

Sales & service partners
www.ewm-group.com/en/specialist-dealers



"More than 400 EWM sales partners worldwide"