



**EN**

**Welding machine**

**Picomig 180 puls TKG**

099-005545-EW501

Observe additional system documents!

17.12.2020

**Register now  
and benefit!  
Jetzt Registrieren  
und Profitieren!**

[www.ewm-group.com](http://www.ewm-group.com)



## General instructions

### WARNING



#### **Read the operating instructions!**

**The operating instructions provide an introduction to the safe use of the products.**

- Read and observe the operating instructions for all system components, especially the safety instructions and warning notices!
- Observe the accident prevention regulations and any regional regulations!
- The operating instructions must be kept at the location where the machine is operated.
- Safety and warning labels on the machine indicate any possible risks. Keep these labels clean and legible at all times.
- The machine has been constructed to state-of-the-art standards in line with any applicable regulations and industrial standards. Only trained personnel may operate, service and repair the machine.
- Technical changes due to further development in machine technology may lead to a differing welding behaviour.

**In the event of queries on installation, commissioning, operation or special conditions at the installation site, or on usage, please contact your sales partner or our customer service department on +49 2680 181-0.**

**A list of authorised sales partners can be found at [www.ewm-group.com/en/specialist-dealers](http://www.ewm-group.com/en/specialist-dealers).**

Liability relating to the operation of this equipment is restricted solely to the function of the equipment. No other form of liability, regardless of type, shall be accepted. This exclusion of liability shall be deemed accepted by the user on commissioning the equipment.

The manufacturer is unable to monitor whether or not these instructions or the conditions and methods are observed during installation, operation, usage and maintenance of the equipment.

An incorrectly performed installation can result in material damage and injure persons as a result. For this reason, we do not accept any responsibility or liability for losses, damages or costs arising from incorrect installation, improper operation or incorrect usage and maintenance or any actions connected to this in any way.

#### © EWM AG

Dr. Günter-Henle-Strasse 8  
56271 Mündersbach Germany  
Tel.: +49 2680 181-0, Fax: -244  
Email: [info@ewm-group.com](mailto:info@ewm-group.com)  
**[www.ewm-group.com](http://www.ewm-group.com)**

The copyright to this document remains the property of the manufacturer.

Copying, including extracts, only permitted with written approval.

The content of this document has been prepared and reviewed with all reasonable care. The information provided is subject to change; errors excepted.

# 1 Contents

<b>1</b>	<b>Contents</b> .....	<b>3</b>
<b>2</b>	<b>For your safety</b> .....	<b>5</b>
2.1	Notes on using these operating instructions.....	5
2.2	Explanation of icons.....	6
2.3	Safety instructions.....	7
2.4	Transport and installation .....	10
<b>3</b>	<b>Intended use</b> .....	<b>12</b>
3.1	Applications.....	12
3.2	Software version .....	12
3.3	Documents which also apply .....	12
3.3.1	Warranty .....	12
3.3.2	Declaration of Conformity.....	12
3.3.3	Welding in environments with increased electrical hazards.....	12
3.3.4	Service documents (spare parts and circuit diagrams).....	12
3.3.5	Calibration/Validation .....	12
3.3.6	Part of the complete documentation.....	13
<b>4</b>	<b>Machine description – quick overview</b> .....	<b>14</b>
4.1	Front view .....	14
4.2	Inside view .....	16
4.3	Machine control – Operating elements .....	18
4.3.1	Welding data display .....	20
4.3.1.1	Polarity setting.....	20
<b>5</b>	<b>Design and function</b> .....	<b>21</b>
5.1	Transport and installation .....	21
5.1.1	Ambient conditions .....	21
5.1.1.1	In operation .....	21
5.1.1.2	Transport and storage.....	21
5.1.2	Machine cooling.....	21
5.1.3	Workpiece lead, general.....	22
5.1.4	Notes on the installation of welding current leads.....	22
5.1.5	Stray welding currents .....	24
5.1.6	Mains connection.....	25
5.1.6.1	Mains configuration .....	25
5.1.7	Shielding gas supply (shielding gas cylinder for welding machine) .....	25
5.1.7.1	Pressure regulator connection .....	26
5.1.7.2	Shielding gas hose connection .....	26
5.1.7.3	Gas test – setting the shielding gas volume .....	27
5.2	MIG/MAG welding.....	28
5.2.1	Welding torch and workpiece line connection .....	28
5.2.2	Wire feed .....	30
5.2.2.1	Inserting the wire spool .....	30
5.2.2.2	Changing the wire feed rollers .....	31
5.2.2.3	Inching the wire electrode .....	32
5.2.2.4	Spool brake setting .....	33
5.2.3	Definition of MIG/MAG welding tasks.....	33
5.2.4	Welding task selection.....	34
5.2.5	Welding power (operating point) .....	34
5.2.5.1	Selecting the welding parameter display mode .....	34
5.2.5.2	Operating point setting using material thickness .....	34
5.2.5.3	Arc length.....	35
5.2.6	Further welding parameters .....	35
5.2.7	Operating modes (functional sequences) .....	36
5.2.7.1	Explanation of signs and functions .....	36
5.2.7.2	Automatic cut-out.....	36
5.2.8	Conventional MIG/MAG Welding (GMAW non synergic).....	40
5.3	MMA welding .....	41
5.3.1	Connecting the electrode holder and workpiece lead .....	41
5.3.2	Welding task selection.....	42

5.3.3	Arcforce.....	42
5.3.4	Hotstart .....	42
	5.3.4.1 Hotstart settings .....	43
5.3.5	Antistick.....	43
5.4	TIG welding .....	43
5.4.1	Preparing the TIG welding torch.....	43
5.4.2	Welding torch and workpiece line connection .....	44
5.4.3	Welding task selection .....	45
5.4.4	Adjusting the gas post-flow time.....	45
5.4.5	Further welding parameters.....	46
5.4.6	Operating modes (functional sequences).....	47
	5.4.6.1 Legend.....	47
	5.4.6.2 Automatic cut-out .....	47
5.4.7	Arc ignition .....	50
	5.4.7.1 Liftarc.....	50
5.5	Machine configuration menu .....	50
5.5.1	Selecting, changing and saving parameters.....	50
5.6	Power-saving mode (Standby).....	51
<b>6</b>	<b>Maintenance, care and disposal .....</b>	<b>52</b>
6.1	General.....	52
6.1.1	Cleaning.....	52
6.1.2	Dirt filter.....	52
6.2	Maintenance work, intervals .....	53
6.2.1	Daily maintenance tasks.....	53
6.2.2	Monthly maintenance tasks .....	53
6.2.3	Annual test (inspection and testing during operation) .....	53
6.3	Disposing of equipment.....	54
<b>7</b>	<b>Rectifying faults.....</b>	<b>55</b>
7.1	Checklist for rectifying faults .....	55
7.2	Error messages (power source).....	57
7.3	Resetting welding parameters to the factory settings .....	58
7.4	Display machine control software version.....	58
7.5	Dynamic power adjustment.....	58
<b>8</b>	<b>Technical data.....</b>	<b>59</b>
8.1	Picomig 180 puls TKG .....	59
<b>9</b>	<b>Accessories .....</b>	<b>60</b>
9.1	General accessories .....	60
9.2	Options.....	60
9.3	Transport system .....	60
<b>10</b>	<b>Replaceable parts.....</b>	<b>61</b>
10.1	Wire feed rollers .....	61
10.1.1	Wire feed rollers for steel wire .....	61
10.1.2	Wire feed rollers for aluminium wire .....	61
10.1.3	Wire feed rollers for cored wire.....	61
10.1.4	Conversion kit.....	62
<b>11</b>	<b>Appendix .....</b>	<b>63</b>
11.1	JOB-List.....	63
11.2	Parameter overview – setting ranges .....	63
11.3	Searching for a dealer.....	65

## 2 For your safety

### 2.1 Notes on using these operating instructions

#### **DANGER**

**Working or operating procedures which must be closely observed to prevent imminent serious and even fatal injuries.**

- Safety notes include the "DANGER" keyword in the heading with a general warning symbol.
- The hazard is also highlighted using a symbol on the edge of the page.

#### **WARNING**

**Working or operating procedures which must be closely observed to prevent serious and even fatal injuries.**

- Safety notes include the "WARNING" keyword in the heading with a general warning symbol.
- The hazard is also highlighted using a symbol in the page margin.

#### **CAUTION**

**Working or operating procedures which must be closely observed to prevent possible minor personal injury.**

- The safety information includes the "CAUTION" keyword in its heading with a general warning symbol.
- The risk is explained using a symbol on the edge of the page.



**Technical aspects which the user must observe to avoid material or equipment damage.**

Instructions and lists detailing step-by-step actions for given situations can be recognised via bullet points, e.g.:

- Insert the welding current lead socket into the relevant socket and lock.

## 2.2 Explanation of icons

Symbol	Description	Symbol	Description
	Indicates technical aspects which the user must observe.		Activate and release / Tap / Tip
	Switch off machine		Release
	Switch on machine		Press and hold
			Switch
	Incorrect / Invalid		Turn
	Correct / Valid		Numerical value – adjustable
	Input		Signal light lights up in green
	Navigation		Signal light flashes green
	Output		Signal light lights up in red
	Time representation (e.g.: wait 4 s / actuate)		Signal light flashes red
	Interruption in the menu display (other setting options possible)		
	Tool not required/do not use		
	Tool required/use		

## 2.3 Safety instructions

### WARNING



**Risk of accidents due to non-compliance with the safety instructions!**  
**Non-compliance with the safety instructions can be fatal!**

- Carefully read the safety instructions in this manual!
- Observe the accident prevention regulations and any regional regulations!
- Inform persons in the working area that they must comply with the regulations!



**Risk of injury from electrical voltage!**

**Voltages can cause potentially fatal electric shocks and burns on contact. Even low voltages can cause a shock and lead to accidents.**

- Never touch live components such as welding current sockets or stick, tungsten or wire electrodes!
- Always place torches and electrode holders on an insulated surface!
- Wear the full personal protective equipment (depending on the application)!
- The machine may only be opened by qualified personnel!
- The device must not be used to defrost pipes!



**Hazard when interconnecting multiple power sources!**

**If a number of power sources are to be connected in parallel or in series, only a technical specialist may interconnect the sources as per standard IEC 60974-9:2010: Installation and use and German Accident Prevention Regulation BVG D1 (formerly VBG 15) or country-specific regulations.**

**Before commencing arc welding, a test must verify that the equipment cannot exceed the maximum permitted open circuit voltage.**

- Only qualified personnel may connect the machine.
- When taking individual power sources out of operation, all mains and welding current leads must be safely disconnected from the welding system as a whole. (Hazard due to reverse polarity voltage!)
- Do not interconnect welding machines with pole reversing switch (PWS series) or machines for AC welding since a minor error in operation can cause the welding voltages to be combined, which is not permitted.



**Risk of injury due to radiation or heat!**

**Arc radiation can lead to skin and eye injuries.**

**Contact with hot workpieces and sparks can lead to burns.**

- Use hand shield or welding helmet with the appropriate safety level (depends on the application).
- Wear dry protective clothing (e.g. hand shield, gloves, etc.) in accordance with the applicable regulations of your country.
- Persons who are not directly involved should be protected with a welding curtain or suitable safety screen against radiation and the risk of blinding!

## **WARNING**



### **Risk of injury due to improper clothing!**

**During arc welding, radiation, heat and voltage are sources of risk that cannot be avoided. The user has to be equipped with the complete personal protective equipment at all times. The protective equipment has to include:**

- Respiratory protection against hazardous substances and mixtures (fumes and vapours); otherwise implement suitable measures such as extraction facilities.
- Welding helmet with proper protection against ionizing radiation (IR and UV radiation) and heat.
- Dry welding clothing (shoes, gloves and body protection) to protect against warm environments with conditions comparable to ambient temperatures of 100 °C or higher and arcing and work on live components.
- Hearing protection against harming noise.



### **Explosion risk!**

**Apparently harmless substances in closed containers may generate excessive pressure when heated.**

- Move containers with inflammable or explosive liquids away from the working area!
- Never heat explosive liquids, dusts or gases by welding or cutting!



### **Fire hazard!**

**Due to the high temperatures, sparks, glowing parts and hot slag that occur during welding, there is a risk of flames.**

- Be watchful of potential sources of fire in the working area!
- Do not carry any easily inflammable objects, e.g. matches or lighters.
- Ensure suitable fire extinguishers are available in the working area!
- Thoroughly remove any residue of flammable materials from the workpiece prior to starting to weld.
- Only further process workpieces after they have cooled down. Do not allow them to contact any flammable materials!



**⚠ CAUTION****Smoke and gases!**

**Smoke and gases can lead to breathing difficulties and poisoning. In addition, solvent vapour (chlorinated hydrocarbon) may be converted into poisonous phosgene due to the ultraviolet radiation of the arc!**

- Ensure that there is sufficient fresh air!
- Keep solvent vapour away from the arc beam field!
- Wear suitable breathing apparatus if appropriate!

**Noise exposure!**

**Noise exceeding 70 dBA can cause permanent hearing damage!**

- Wear suitable ear protection!
- Persons located within the working area must wear suitable ear protection!



**According to IEC 60974-10, welding machines are divided into two classes of electromagnetic compatibility (the EMC class can be found in the Technical data) > see 8 chapter:**



**Class A** machines are not intended for use in residential areas where the power supply comes from the low-voltage public mains network. When ensuring the electromagnetic compatibility of class A machines, difficulties can arise in these areas due to interference not only in the supply lines but also in the form of radiated interference.



**Class B** machines fulfil the EMC requirements in industrial as well as residential areas, including residential areas connected to the low-voltage public mains network.

**Setting up and operating**

When operating arc welding systems, in some cases, electro-magnetic interference can occur although all of the welding machines comply with the emission limits specified in the standard. The user is responsible for any interference caused by welding.

In order to **evaluate** any possible problems with electromagnetic compatibility in the surrounding area, the user must consider the following: (see also EN 60974-10 Appendix A)

- Mains, control, signal and telecommunication lines
- Radios and televisions
- Computers and other control systems
- Safety equipment
- The health of neighbouring persons, especially if they have a pacemaker or wear a hearing aid
- Calibration and measuring equipment
- The immunity to interference of other equipment in the surrounding area
- The time of day at which the welding work must be carried out

**Recommendations for reducing interference emission**

- Mains connection, e.g. additional mains filter or shielding with a metal tube
- Maintenance of the arc welding system
- Welding leads should be as short as possible and run closely together along the ground
- Potential equalization
- Earthing of the workpiece. In cases where it is not possible to earth the workpiece directly, it should be connected by means of suitable capacitors.
- Shielding from other equipment in the surrounding area or the entire welding system

**Electromagnetic fields!**

**The power source may cause electrical or electromagnetic fields to be produced which could affect the correct functioning of electronic equipment such as IT or CNC devices, telecommunication lines, power cables, signal lines and pacemakers.**



- Observe the maintenance instructions > see 6.2 chapter!
- Unwind welding leads completely!
- Shield devices or equipment sensitive to radiation accordingly!
- The correct functioning of pacemakers may be affected (obtain advice from a doctor if necessary).

## CAUTION



### Obligations of the operator!

**The respective national directives and laws must be complied with when operating the machine!**

- Implementation of national legislation relating to framework directive 89/391/EEC on the introduction of measures to encourage improvements in the safety and health of workers at work and associated individual guidelines.
- In particular, directive 89/655/EEC concerning the minimum safety and health requirements for the use of work equipment by workers at work.
- The regulations applicable to occupational safety and accident prevention in the country concerned.
- Setting up and operating the machine as per IEC 60974.-9.
- Brief the user on safety-conscious work practices on a regular basis.
- Regularly inspect the machine as per IEC 60974.-4.



***The manufacturer's warranty becomes void if non-genuine parts are used!***

- ***Only use system components and options (power sources, welding torches, electrode holders, remote controls, spare parts and replacement parts, etc.) from our range of products!***
- ***Only insert and lock accessory components into the relevant connection socket when the machine is switched off.***

### Requirements for connection to the public mains network

High-performance machines can influence the mains quality by taking current from the mains network. For some types of machines, connection restrictions or requirements relating to the maximum possible line impedance or the necessary minimum supply capacity at the interface with the public network (Point of Common Coupling, PCC) can therefore apply. In this respect, attention is also drawn to the machines' technical data. In this case, it is the responsibility of the operator, where necessary in consultation with the mains network operator, to ensure that the machine can be connected.

## 2.4 Transport and installation

## WARNING



### Risk of injury due to improper handling of shielding gas cylinders!

**Improper handling and insufficient securing of shielding gas cylinders can cause serious injuries!**

- Observe the instructions from the gas manufacturer and any relevant regulations concerning the use of compressed air!
- Do not attach any element to the shielding gas cylinder valve!
- Prevent the shielding gas cylinder from heating up.

**⚠ CAUTION****Risk of accidents due to supply lines!**

During transport, attached supply lines (mains leads, control cables, etc.) can cause risks, e.g. by causing connected machines to tip over and injure persons!

- Disconnect all supply lines before transport!

**Risk of tipping!**

There is a risk of the machine tipping over and injuring persons or being damaged itself during movement and set up. Tilt resistance is guaranteed up to an angle of 10° (according to IEC 60974-1).

- Set up and transport the machine on level, solid ground.
- Secure add-on parts using suitable equipment.

**Risk of accidents due to incorrectly installed leads!**

Incorrectly installed leads (mains, control and welding leads or intermediate hose packages) can present a tripping hazard.

- Lay the supply lines flat on the floor (avoid loops).
- Avoid laying the leads on passage ways.

**Risk of injury from heated coolant and its connections!**

The coolant used and its connection or connection points can heat up significantly during operation (water-cooled version). When opening the coolant circuit, escaping coolant may cause scalding.

- Open the coolant circuit only when the power source or cooling unit is switched off!
- Wear proper protective equipment (protective gloves)!
- Seal open connections of the hose leads with suitable plugs.



***The units are designed for operation in an upright position!***

***Operation in non-permissible positions can cause equipment damage.***

- ***Only transport and operate in an upright position!***



***Accessory components and the power source itself can be damaged by incorrect connection!***

- ***Only insert and lock accessory components into the relevant connection socket when the machine is switched off.***
- ***Comprehensive descriptions can be found in the operating instructions for the relevant accessory components.***
- ***Accessory components are detected automatically after the power source is switched on.***



***Protective dust caps protect the connection sockets and therefore the machine against dirt and damage.***

- ***The protective dust cap must be fitted if there is no accessory component being operated on that connection.***
- ***The cap must be replaced if faulty or if lost!***

### 3 Intended use

#### WARNING



##### Hazards due to improper usage!

The machine has been constructed to the state of the art and any regulations and standards applicable for use in industry and trade. It may only be used for the welding procedures indicated at the rating plate. Hazards may arise for persons, animals and material objects if the equipment is not used correctly. No liability is accepted for any damages arising from improper usage!

- The equipment must only be used in line with its designated purpose and by trained or expert personnel!
- Do not improperly modify or convert the equipment!

### 3.1 Applications

Arc welding machine for standard and pulsed gas-shielded metal-arc welding with TIG welding and lift arc (touch starting) or MMA welding as secondary process. It may be possible to expand the functionality by using accessories (see the documentation in the relevant chapter).

### 3.2 Software version

These instructions apply to the following software version:

0.5.9.0

**The software version of the machine control can be displayed in the machine configuration menu (menu Srv) > see 5.5 chapter.**

### 3.3 Documents which also apply

#### 3.3.1 Warranty

For more information refer to the "Warranty registration" brochure supplied and our information regarding warranty, maintenance and testing at [www.ewm-group.com](http://www.ewm-group.com)!

#### 3.3.2 Declaration of Conformity



This product corresponds in its design and construction to the EU directives listed in the declaration. The product comes with a relevant declaration of conformity in the original.

The manufacturer recommends carrying out the safety inspection according to national and international standards and guidelines every 12 months.

#### 3.3.3 Welding in environments with increased electrical hazards



Power sources with this marking can be used for welding in an environment with increased electrical hazard (e.g. boilers). For this purpose, appropriate national or international regulations must be followed. The power source must not be placed in the danger zone!

#### 3.3.4 Service documents (spare parts and circuit diagrams)

#### WARNING



##### Do not carry out any unauthorised repairs or modifications!

To avoid injury and equipment damage, the unit must only be repaired or modified by specialist, skilled persons!

**The warranty becomes null and void in the event of unauthorised interference.**

- Appoint only skilled persons for repair work (trained service personnel)!

Original copies of the circuit diagrams are enclosed with the unit.

Spare parts can be obtained from the relevant authorised dealer.

#### 3.3.5 Calibration/Validation

An original certificate is enclosed with the product. The manufacturer recommends calibration / validation at intervals of 12 months.

### 3.3.6 Part of the complete documentation

This document is part of the complete documentation and valid only in combination with all other parts of these instructions! Read and observe the operating instructions for all system components, especially the safety instructions!

The illustration shows a general example of a welding system.

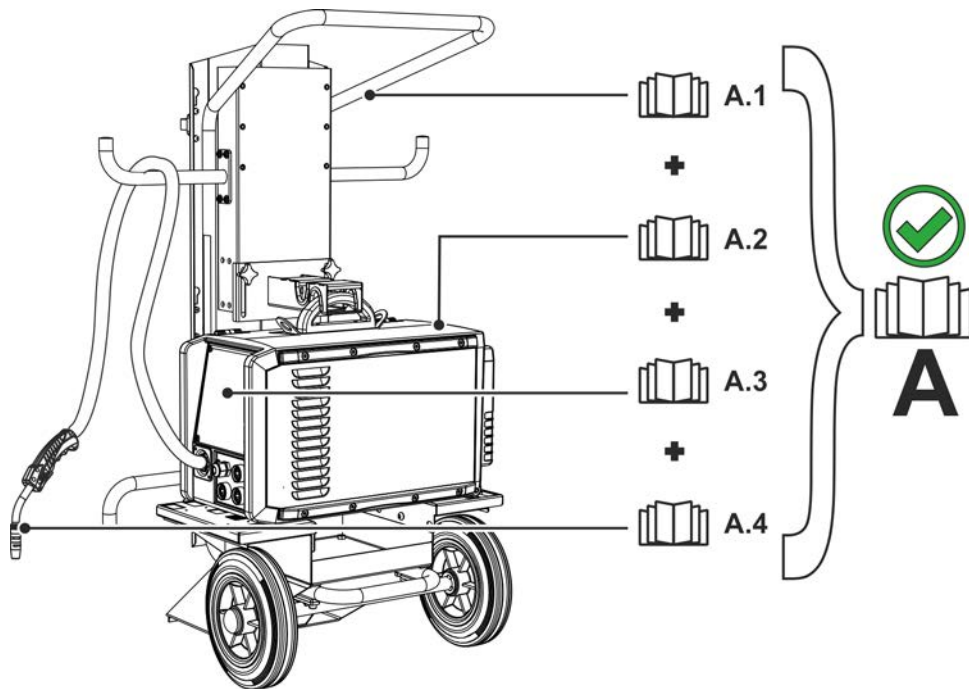

Figure 3-1

Item	Documentation
A.1	Transport cart
A.2	Power source
A.3	Controller
A.4	Welding torch
A	Complete documentation

## 4 Machine description – quick overview

### 4.1 Front view

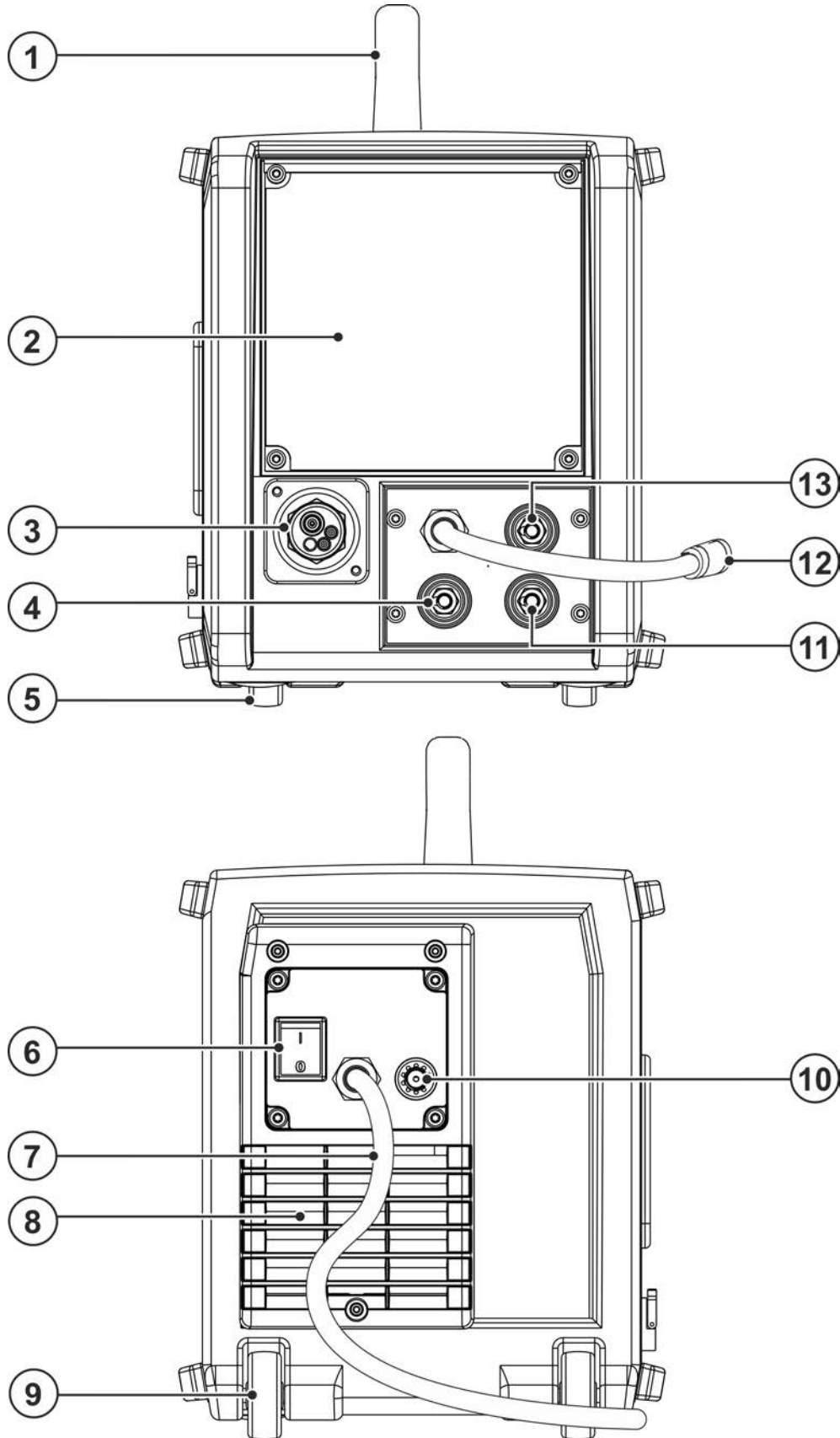





Figure 4-1

Item	Symbol	Description
1		<b>Carrying handle</b>
2		<b>Machine control &gt; see 4.3 chapter</b>
3		<b>Welding torch connection (Euro torch connector)</b> Welding current, shielding gas and torch trigger integrated
4		<b>Connection socket, "+" welding current</b> <ul style="list-style-type: none"> <li>•-----MIG/MAG cored wire welding:      Workpiece connection</li> <li>•-----TIG welding:                              Workpiece connection</li> <li>•-----MMA welding:                              Workpiece connection</li> </ul>
5		<b>Machine feet</b>
6		<b>Main Switch</b> Switching the machine on or off.
7		<b>Mains connection cable with connector plug</b>
8		<b>Cooling air inlet</b>
9		<b>Wheels</b>
10		<b>Connection thread - G<sup>1</sup>/<sub>4</sub>"</b> Shielding gas connection (inlet)
11		<b>"-" welding current connection socket</b> <ul style="list-style-type: none"> <li>•-----MIG/MAG welding:                      Workpiece connection</li> <li>•-----TIG welding:                              Welding current connection for welding torch</li> <li>•-----MMA welding:                              electrode holder connection</li> </ul>
12		<b>Polarity selection plug, welding current cable &gt; see 4.3.1.1 chapter</b>
13		<b>Park socket, polarity selection plug</b> Retainer for the polarity selection plug in MMA mode or for transport.

## 4.2 Inside view

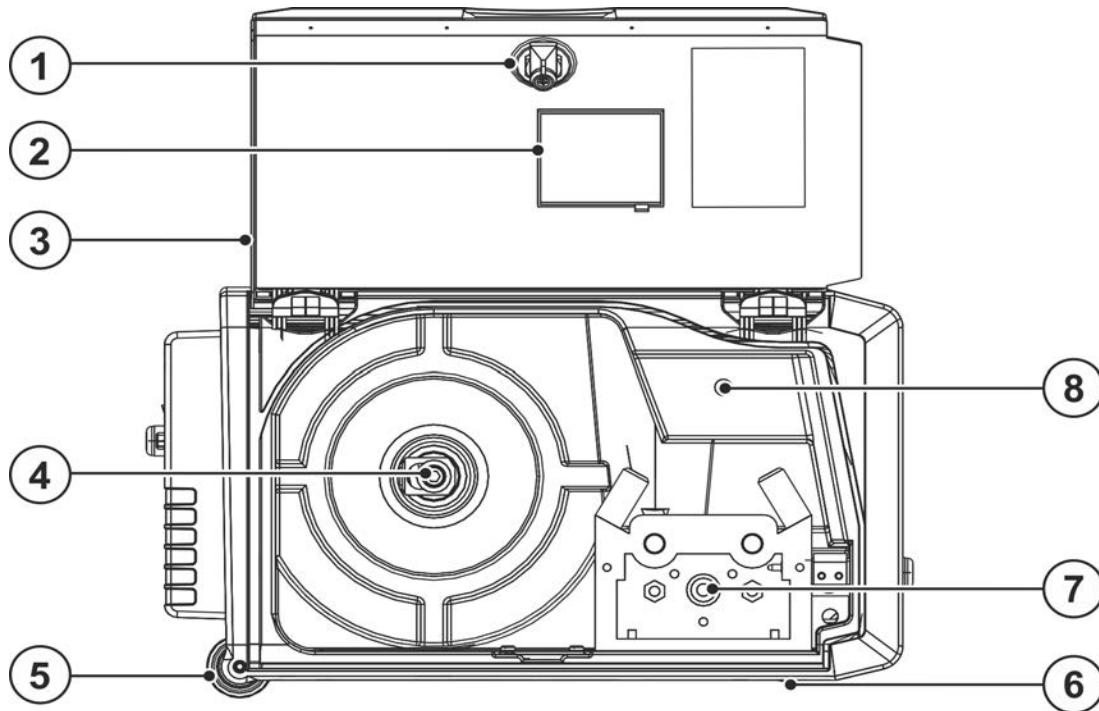



Figure 4-2



Item	Symbol	Description
1		<b>Rotary closure</b> Locking of the protective cap
2		<b>Wire spool inspection window</b> Check wire supply
3		<b>Protective cap</b> Cover for the wire feed mechanism and other operating elements. Depending on the machine series, additional stickers with information on the replacement parts and JOB lists will be located on the inside.
4		<b>Wire spool holder</b>
5		<b>Wheels</b>
6		<b>Machine feet</b>
7		<b>Wire feed unit</b>
8		<b>Push-button, wire inching</b> Potential- and gas-free inching of the wire electrode through the hose package to the welding torch > see 5.2.2.3 chapter.

## 4.3 Machine control – Operating elements

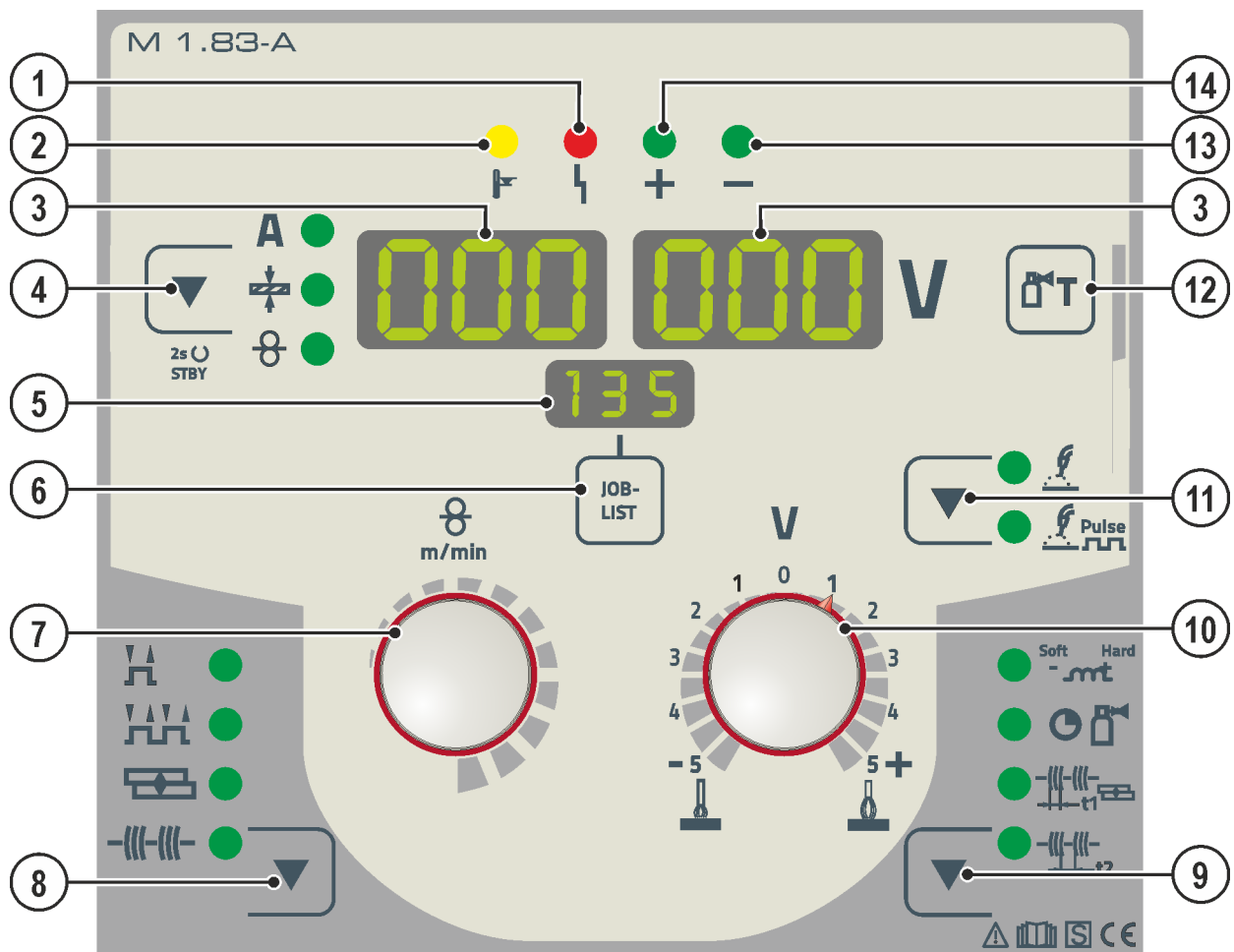

Figure 4-3

Item	Symbol	Description
1		“Collective interference” signal light
2		“Excess temperature” signal light
3		<b>Welding data display (3-digit)</b> Displays the welding parameters and the corresponding values > see 4.3.1 chapter
4		<b>Welding parameter display mode/power-saving mode push-button</b> A ----- Welding current + ----- Material thickness ⊗ ----- Wire feed speed Press for 2 s to put the machine into power-saving mode. Activate one of the operating elements to reactivate > see 5.6 chapter.
5		<b>Display, JOB</b> Shows the currently selected welding task (JOB number).
6	<b>JOB-LIST</b>	<b>Welding task push-button (JOB)</b> Select the welding task from the welding task list (JOB-LIST). The list can be found inside the protective cap on the wire feeder and in the appendix to these operating instructions.
7		<b>Welding parameter setting dial</b> For setting the welding performance, for selecting the JOB (welding task) and for setting other welding parameters.

Item	Symbol	Description
8		<b>Operating mode button</b> ----- Non-latched ----- Latched ----- Spots ----- Interval
9		<b>Runtime parameters button</b> For selecting the parameters to be set. Also for entering and exiting the menus for advanced settings. ----- Choke effect/dynamics ----- Gas post-flow time ----- Spot time ----- Pause time
10		<b>Arc length correction rotary dial</b>
11		<b>Welding type push-button</b> ----- Standard arc welding ----- Pulsed arc welding
12		<b>Gas test push-button &gt; see 5.1.7.3 chapter</b>
13		<b>Signal light polarity setting</b>
14		<b>Signal light polarity setting</b>

## 4.3.1 Welding data display

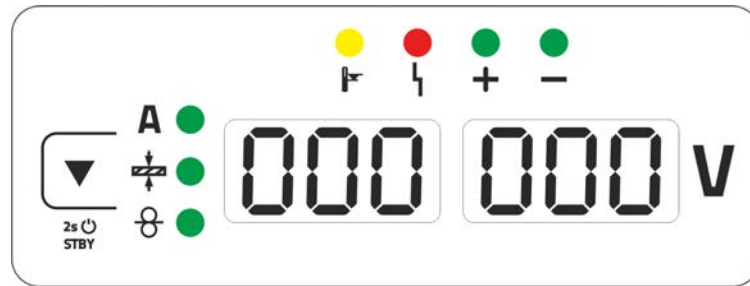

Figure 4-4

The push-button for the welding parameter display mode is next to the display.

Each time the push-button is pressed the display changes to the next parameter. After the last parameter is reached the display continues with the first parameter.

The display shows:

- Nominal values (before welding)
- Actual values (during welding)
- Hold values (after welding)

### MIG/MAG

Parameter	Nominal values	Actual values	Hold values
Welding current	<input checked="" type="checkbox"/> / <input type="checkbox"/> [1]	<input checked="" type="checkbox"/>	<input checked="" type="checkbox"/>
Material thickness	<input checked="" type="checkbox"/>	<input type="checkbox"/>	<input type="checkbox"/>
Wire feed speed	<input checked="" type="checkbox"/>	<input type="checkbox"/>	<input type="checkbox"/>
Welding voltage	<input checked="" type="checkbox"/>	<input checked="" type="checkbox"/>	<input checked="" type="checkbox"/>

[1] traditional MIG/MAG

### TIG/MMA

Parameter	Nominal values	Actual values	Hold values
Welding current	<input checked="" type="checkbox"/>	<input type="checkbox"/>	<input type="checkbox"/>
Welding voltage	<input type="checkbox"/>	<input checked="" type="checkbox"/>	<input checked="" type="checkbox"/>

After the welding, the display switches from hold values to nominal values by

- pressing the push-buttons or turning the rotary knobs of the control
- waiting for about 5 seconds

### 4.3.1.1 Polarity setting

The polarity setting displays the polarity required for the selected JOB on the machine control > see 4.3 chapter. The required polarity can then be set with the polarity selection plug.

## 5 Design and function

### ⚠ WARNING



**Risk of injury from electrical voltage!**

**Contact with live parts, e.g. power connections, can be fatal!**

- Observe the safety information on the first pages of the operating instructions!
- Commissioning must be carried out by persons who are specifically trained in handling power sources!
- Connect connection or power cables while the machine is switched off!

Read and observe the documentation to all system and accessory components!

### 5.1 Transport and installation

### ⚠ WARNING



**Risk of accident due to improper transport of machines that must not be lifted!**

**Do not lift or suspend the machine! The machine can drop and cause injuries! The handles, straps or brackets are suitable for transport by hand only!**

- The machine must not be suspended or lifted using a crane.

#### 5.1.1 Ambient conditions



***The machine must not be operated in the open air and must only be set up and operated on a suitable, stable and level base!***

- ***The operator must ensure that the ground is non-slip and level, and provide sufficient lighting for the place of work.***
- ***Safe operation of the machine must be guaranteed at all times.***



***Equipment damage due to contamination!***

***Unusually high amounts of dust, acids, corrosive gases or substances can damage the machine (observe maintenance intervals > see 6.2 chapter).***

- ***Avoid large amounts of smoke, steam, oily fumes, grinding dust and corrosive ambient air!***

##### 5.1.1.1 In operation

**Temperature range of the ambient air:**

- -25 °C to +40 °C (-13 °F to 104 °F) <sup>[1]</sup>

**Relative humidity:**

- up to 50 % at 40 °C (104 °F)
- up to 90 % at 20 °C (68 °F)

##### 5.1.1.2 Transport and storage

**Storage in a closed room, temperature range of the ambient air:**

- -30 °C to +70 °C (-22 °F to 158 °F) <sup>[1]</sup>

**Relative humidity**

- up to 90 % at 20 °C (68 °F)

<sup>[1]</sup> Ambient temperature dependent on coolant! Observe the coolant temperature range of the torch cooling

#### 5.1.2 Machine cooling



***Insufficient ventilation results in a reduction in performance and equipment damage.***

- ***Observe the ambient conditions!***
- ***Keep the cooling air inlet and outlet clear!***
- ***Observe the minimum distance of 0.5 m from obstacles!***

## 5.1.3 Workpiece lead, general

### ⚠ CAUTION



**Risk of burning due to incorrect welding current connection!**

**If the welding current plugs (machine connections) are not locked or if the workpiece connection is contaminated (paint, corrosion), these connections and leads can heat up and cause burns when touched!**

- Check welding current connections on a daily basis and lock by turning to the right when necessary.
- Clean workpiece connection thoroughly and secure properly. Do not use structural parts of the workpiece as welding current return lead!

## 5.1.4 Notes on the installation of welding current leads

- Incorrectly installed welding current leads can cause faults in the arc (flickering).
- Lay the workpiece lead and hose package of power sources without HF igniter (MIG/MAG) for as long and as close as possible in parallel.
- Lay the workpiece lead and hose package of power sources with HF igniter (TIG) for as long as possible in parallel with a distance of 20 cm to avoid HF sparkover.
- Always keep a distance of at least 20 cm to leads of other power sources to avoid interferences
- Always keep leads as short as possible! For optimum welding results max. 30 m (welding lead + intermediate hose package + torch lead).

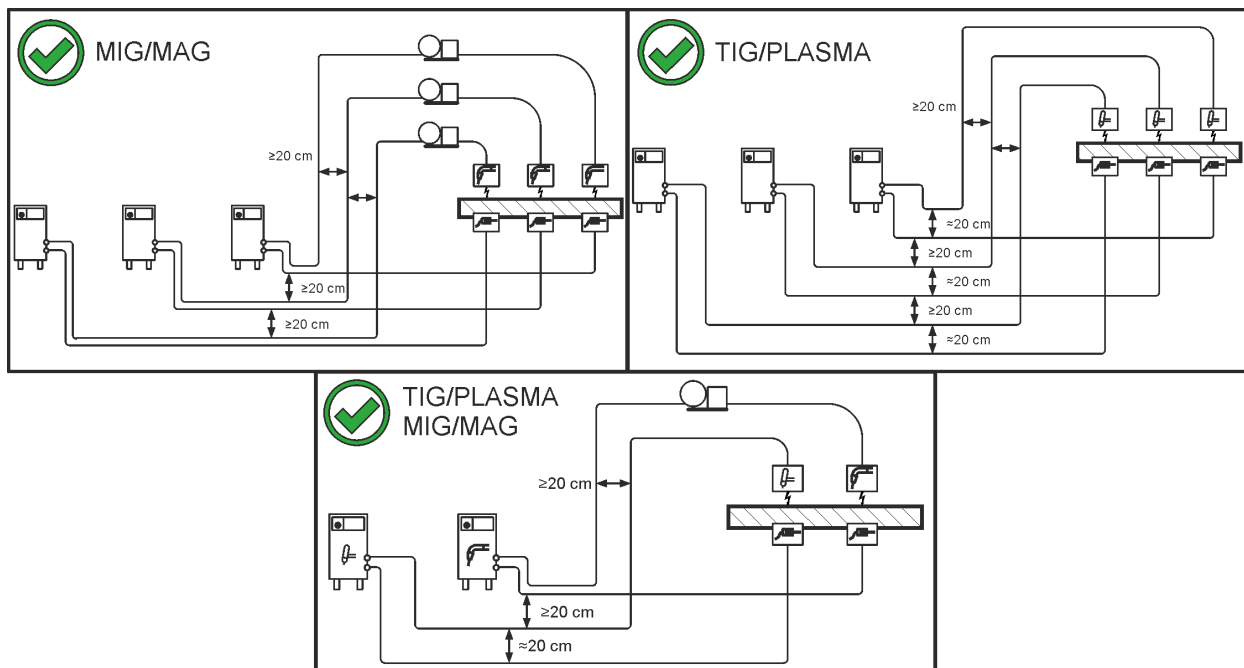

Figure 5-1

- Use an individual welding lead to the workpiece for each welding machine!

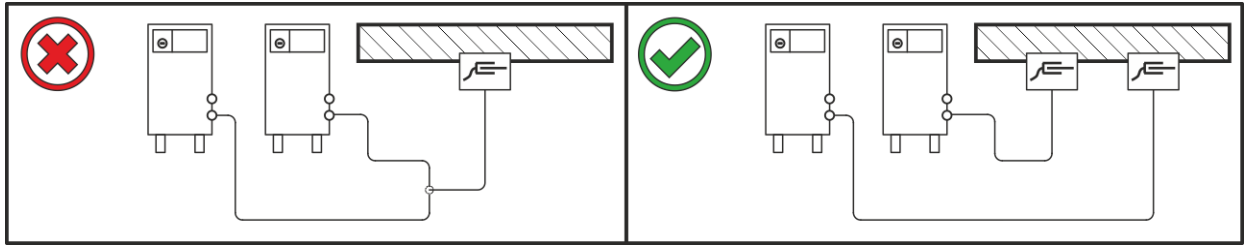

Figure 5-2

- Fully unroll welding current leads, torch hose packages and intermediate hose packages. Avoid loops!
- Always keep leads as short as possible!

**Lay any excess cable lengths in meanders.**

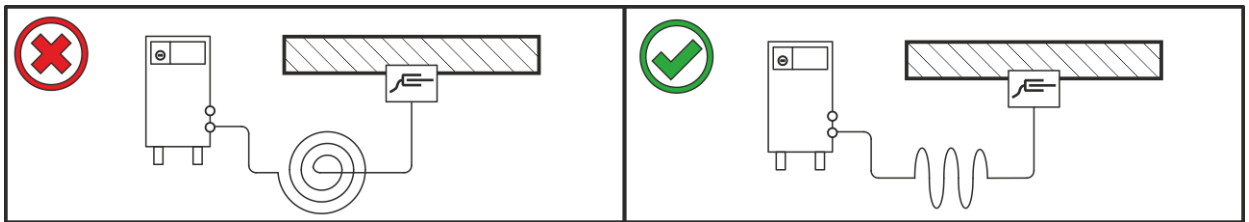

Figure 5-3

## 5.1.5 Stray welding currents

### ⚠ WARNING



**Risk of injury due to stray welding currents!**

**Stray welding currents can destroy protective earth conductors, damage machines and electronic devices and cause overheating of components, leading to fire.**

- Check that all welding current connections are firmly secured and electrical connections are in perfect condition.
- Set up, attach or suspend all conductive power source components such as casing, transport vehicles and crane frames so they are insulated.
- Do not place any other electronic devices such as drills or angle grinders on the power source, transport vehicle or crane frames unless they are insulated.
- Always put welding torches and electrode holders on an insulated surface when they are not in use.

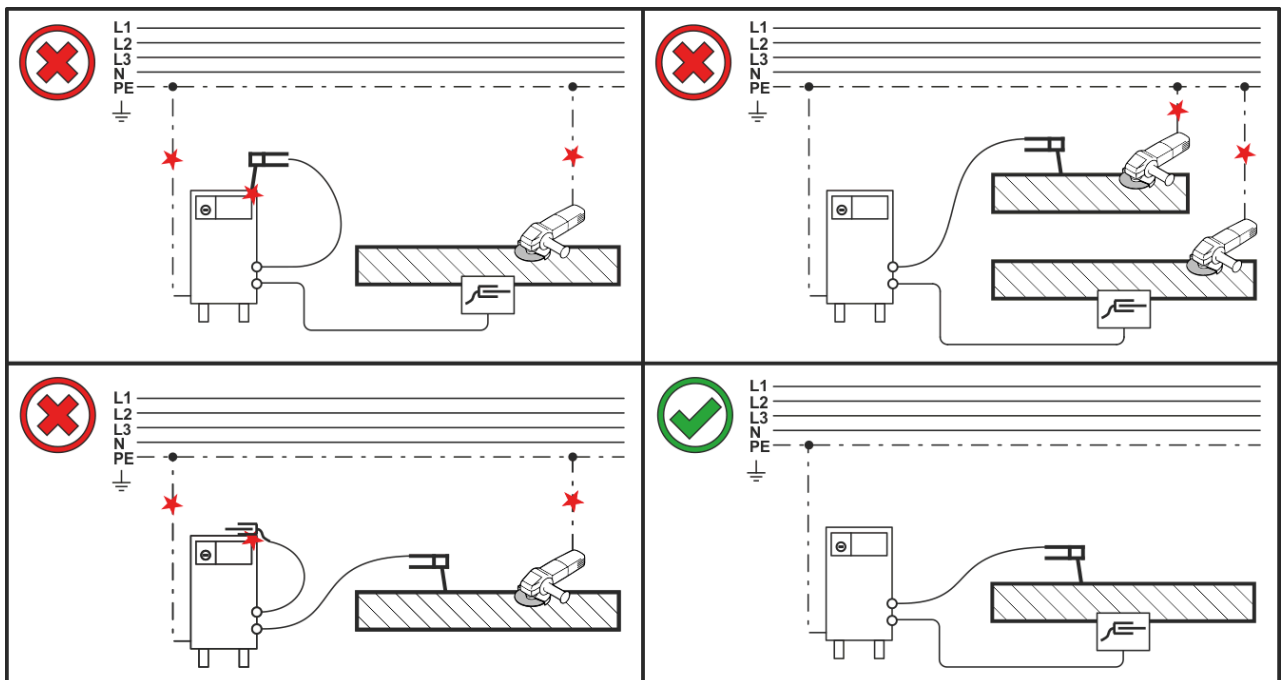

Figure 5-4



## 5.1.6 Mains connection

### ⚠ DANGER



#### Hazards caused by improper mains connection!

#### An improper mains connection can cause injuries or damage property!

- The connection (mains plug or cable), the repair or voltage adjustment of the device must be carried out by a qualified electrician in accordance with the respective local laws or national regulations!
- The mains voltage indicated on the rating plate must match the supply voltage.
- Only operate machine using a socket that has correctly fitted protective earth.
- Mains plug, socket and lead must be checked by a qualified electrician on a regular basis!
- When operating the generator, always ensure it is earthed as stipulated in the operating instructions. The network created must be suitable for operating machines according to protection class I.

### 5.1.6.1 Mains configuration



*The machine may only be connected to a one-phase system with two conductors and an earthed neutral conductor.*

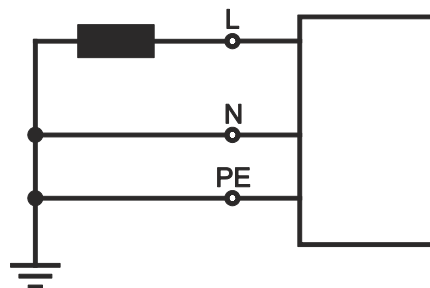

Figure 5-5

#### Legend

Item	Designation	Colour code
L	Outer conductor	brown
N	Neutral conductor	blue
PE	Protective conductor	green-yellow

- Insert mains plug of the switched-off machine into the appropriate socket.

## 5.1.7 Shielding gas supply (shielding gas cylinder for welding machine)

### ⚠ WARNING



#### Risk of injury due to improper handling of shielding gas cylinders!

#### Improper handling and insufficient securing of shielding gas cylinders can cause serious injuries!

- Place shielding gas cylinder into the designated holder and secure with fastening elements (chain/belt)!
- Attach the fastening elements within the upper half of the shielding gas cylinder!
- The fastening elements must tightly enclose the shielding gas cylinder!

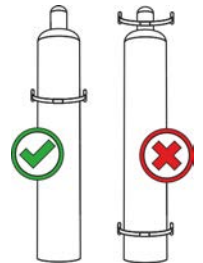

*An unhindered shielding gas supply from the shielding gas cylinder to the welding torch is a fundamental requirement for optimum welding results. In addition, a blocked shielding gas supply may result in the welding torch being destroyed.*

- Always re-fit the yellow protective cap when not using the shielding gas connection.
- All shielding gas connections must be gas tight.

## 5.1.7.1 Pressure regulator connection

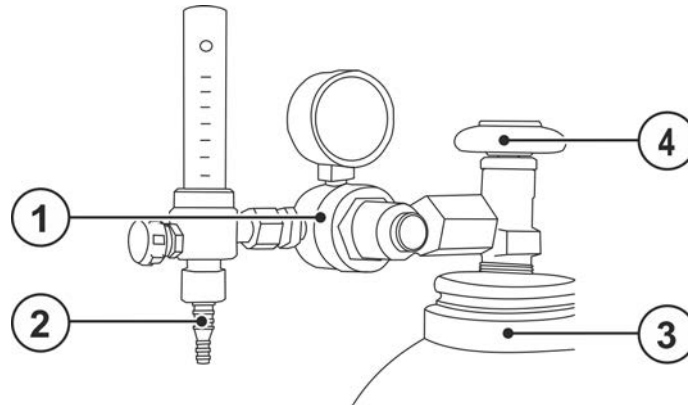

Figure 5-6

Item	Symbol	Description
1		Pressure regulator
2		Output side of the pressure regulator
3		Shielding gas cylinder
4		Cylinder valve

- Before connecting the pressure regulator to the gas cylinder, open the cylinder valve briefly to blow out any dirt.
- Tighten the pressure regulator screw connection on the gas bottle valve to be gas-tight.
- Screw the gas hose connection to the outlet side of the pressure regulator gas-tight.

## 5.1.7.2 Shielding gas hose connection

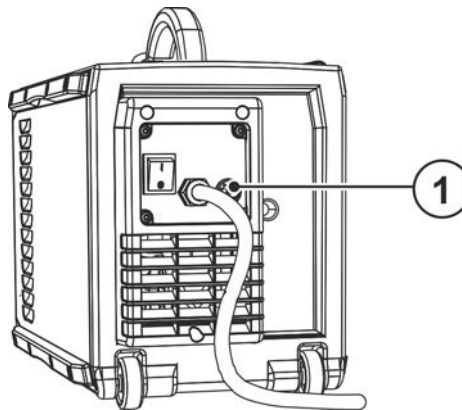



Figure 5-7

Item	Symbol	Description
1		Connection thread - G $\frac{1}{4}$ " Shielding gas connection (inlet)

- Screw the gas hose connection to the shielding gas connection (inlet) on the machine gas-tight.

### 5.1.7.3 Gas test – setting the shielding gas volume

If the shielding gas setting is too low or too high, this can introduce air to the weld pool and may cause pores to form. Adjust the shielding gas quantity to suit the welding task!

- Slowly open the gas cylinder valve.
- Open the pressure regulator.
- Switch on the power source at the main switch.
- Set the relevant gas quantity for the application on the pressure regulator.
- You can activate the gas test by briefly pressing the “Gas test ” push-button on the machine control (welding voltage and wire feed motor remain switched off – no unintentional ignition of the arc).

Shielding gas flows for around 25 seconds or until the button is pressed again.

Repeat rinsing process several times.

#### Setting instructions

Welding process	Recommended shielding gas quantity
MAG welding	Wire diameter x 11.5 = l/min
MIG brazing	Wire diameter x 11.5 = l/min
MIG welding (aluminium)	Wire diameter x 13.5 = l/min (100 % argon)
TIG	Gas nozzle diameter in mm corresponds to l/min gas throughput

#### Helium-rich gas mixtures require a higher gas volume!

The table below can be used to correct the gas volume calculated where necessary:

Shielding gas	Factor
75% Ar/25% He	1.14
50% Ar/50% He	1.35
25% Ar/75% He	1.75
100% He	3.16

## 5.2 MIG/MAG welding

### 5.2.1 Welding torch and workpiece line connection

On delivery, the Euro torch connector is fitted with a capillary tube for welding torches with a steel liner. Conversion is necessary if a welding torch with a liner is used!

- Operate welding torches with a liner > with a guide tube.
- Operate welding torches with a steel liner > with a capillary tube.

**For connection, observe the operating instructions for the welding torch.**

**Depending on the wire electrode diameter or type, either a steel liner or liner with the correct inner diameter must be inserted in the torch!**

Recommendation:

- Use a steel liner when welding hard, unalloyed wire electrodes (steel).
- Use a chrome nickel liner when welding hard, high-alloy wire electrodes (CrNi).
- Use a plastic or teflon liner when welding or brazing soft wire electrodes, high-alloy wire electrodes or aluminium materials.

**Preparation for connecting welding torches with a spiral guide:**

- Check that the capillary tube is correctly positioned in relation to the central connector!

**Preparation for connecting welding torches with a liner:**

- Push forward the capillary tube on the wire feed side in the direction of the Euro torch connector and remove it there.
- Insert the liner guide tube from the Euro torch connector side.
- Carefully insert the welding torch connector with as yet too long a liner into the Euro torch connector and secure with a crown nut.
- Cut off the liner with a liner cutter > *see 9 chapter* just before the wire feed roller.
- Loosen the welding torch connector and remove.
- Carefully chamfer the cut off end of the liner with a liner sharpener > *see 9 chapter* and sharpen.

**Some wire electrodes (e.g. self-shielding cored wire) are welded using negative polarity. In this case, the welding current lead should be connected to the "-" welding current socket, and the workpiece lead should be connected to the "+" welding current socket. Observe the information from the electrode manufacturer!**

Choose welding current connection socket according to the signal light for the polarity setting!

- Select JOB > see 5.2.4 chapter
- Polarity selection “+” or polarity selection “-” signal lights show the polarity setting.

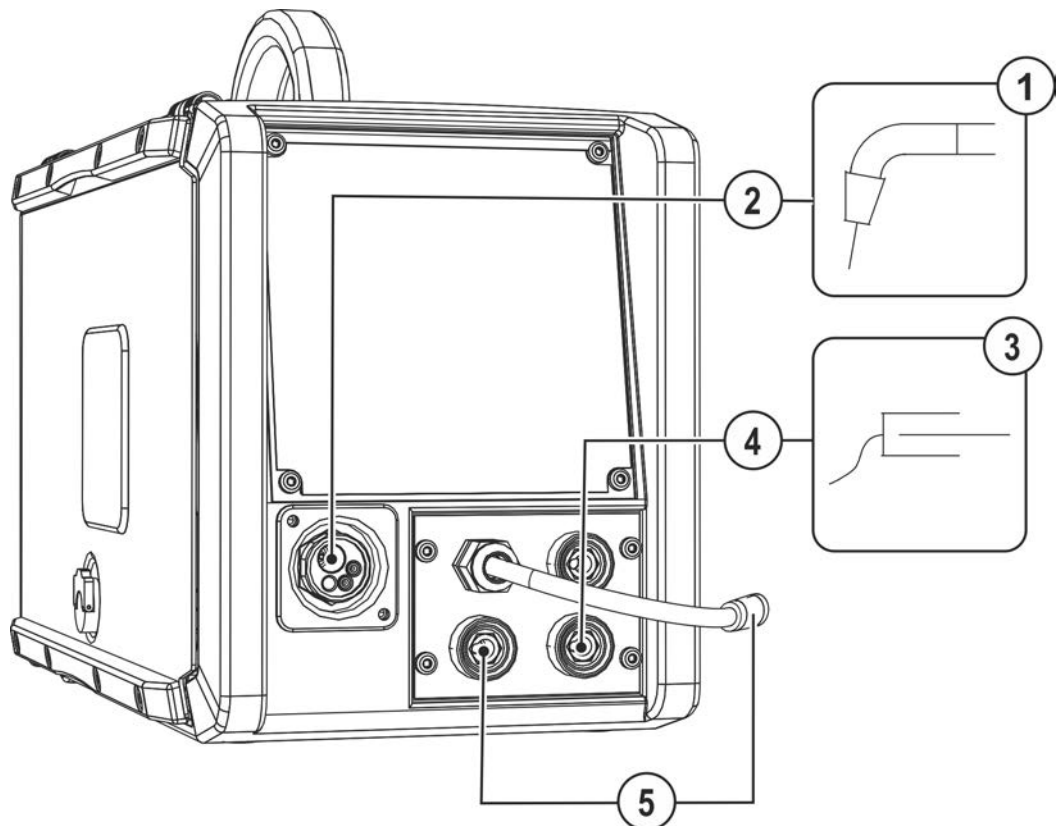

Figure 5-8

Item	Symbol	Description
1		<b>Welding torch</b>
2		<b>Welding torch connection (Euro torch connector)</b> Welding current, shielding gas and torch trigger integrated
3		<b>Workpiece</b>
4		<b>"-" welding current connection socket</b> •-----MIG/MAG welding: Workpiece connection
5		<b>Polarity selector plug, welding current cable</b> Internal welding current cable for central connection/welding torch. •-----Connection socket for "+" welding current

- Insert the central plug for the welding torch into the central connector and screw together with crown nut.
- Insert the plug of the workpiece lead in the respective welding current connection socket and lock in place by turning to the right.
- Insert the polarity selection plug in the respective welding current connection socket and lock in place by turning to the right.

## 5.2.2 Wire feed

### ⚠ CAUTION



**Risk of injury due to moving parts!**

The wire feeders are equipped with moving parts, which can trap hands, hair, clothing or tools and thus injure persons!

- Do not reach into rotating or moving parts or drive components!
- Keep casing covers or protective caps closed during operation!



**Risk of injury due to welding wire escaping in an unpredictable manner!**

Welding wire can be conveyed at very high speeds and, if conveyed incorrectly, may escape in an uncontrolled manner and injure persons!

- Before mains connection, set up the complete wire guide system from the wire spool to the welding torch!
- Check wire guide at regular intervals!
- Keep all casing covers or protective caps closed during operation!

### 5.2.2.1 Inserting the wire spool

### ⚠ CAUTION



**Risk of injury due to incorrectly secured wire spool.**

If the wire spool is not secured properly, it may come loose from the wire spool support and fall to the ground, causing damage to the machine and injuries.

- Make sure to correctly fasten the wire spool to the wire spool support.
- Before you start working, always check the wire spool is securely fastened.

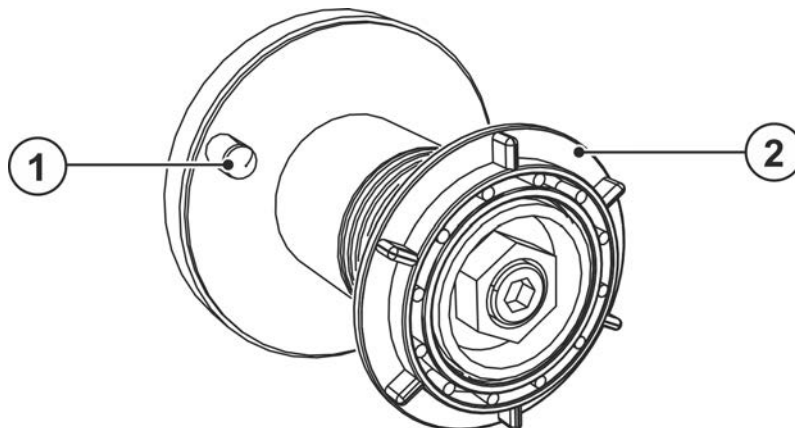

Figure 5-9

Item	Symbol	Description
1		<b>Carrier pin</b> For fixing the wire spool
2		<b>Knurled nut</b> For fixing the wire spool

- Unlock and open protective flap.
- Loosen knurled nut from spool holder.
- Fix welding wire reel onto the spool holder so that the carrier pin locks into the spool bore.
- Fasten wire spool using knurled nut.

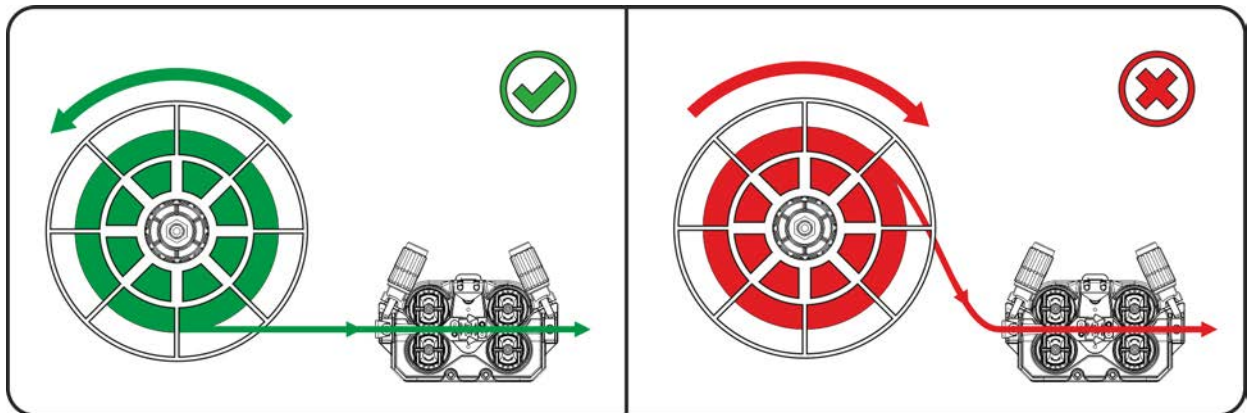

Figure 5-10

### Abspulrichtung der Schweißdrahtspule beachten.

#### 5.2.2.2 Changing the wire feed rollers

Poor welding results due to faulty wire feeding! Wire feed rolls must be suitable for the diameter of the wire and the material.

- Check the label of the rolls whether they fit the wire diameter.  
If necessary, turn or change!
- Use V-groove rolls for steel wires and other hard wires.
- Use driven rolls with U-groove for aluminium wires and other soft, alloyed wires.
- Use driven rolls with knurled U-groove for flux cored wires.
- Slide new drive rollers into place so that the diameter of the wire used is visible on the drive roller.
- Screw the drive rollers in place with knurled screws.

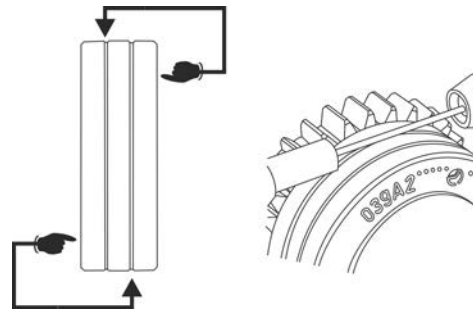

Figure 5-11



## 5.2.2.3 Inching the wire electrode

### ⚠ CAUTION



**Risk of injury due to welding wire escaping from the welding torch!**

The welding wire can escape from the welding torch at high speed and cause bodily injury including injuries to the face and eyes!

- Never direct the welding torch towards your own body or towards other persons!

The inching speed is infinitely adjustable by simultaneously pressing the wire inching push-button and turning the wire speed rotary knob. The left display shows the wire feed speed selected, the right display shows the current motor current of the wire feed mechanism.



**Incorrect contact pressure will cause extensive wear of the wire feed rollers!**

- With the adjusting nuts of the pressure units set the contact pressure so that the wire electrode is conveyed but will still slip through if the wire spool jams.
- Set the contact pressure of the front rollers (in wire feed direction) to a higher value!

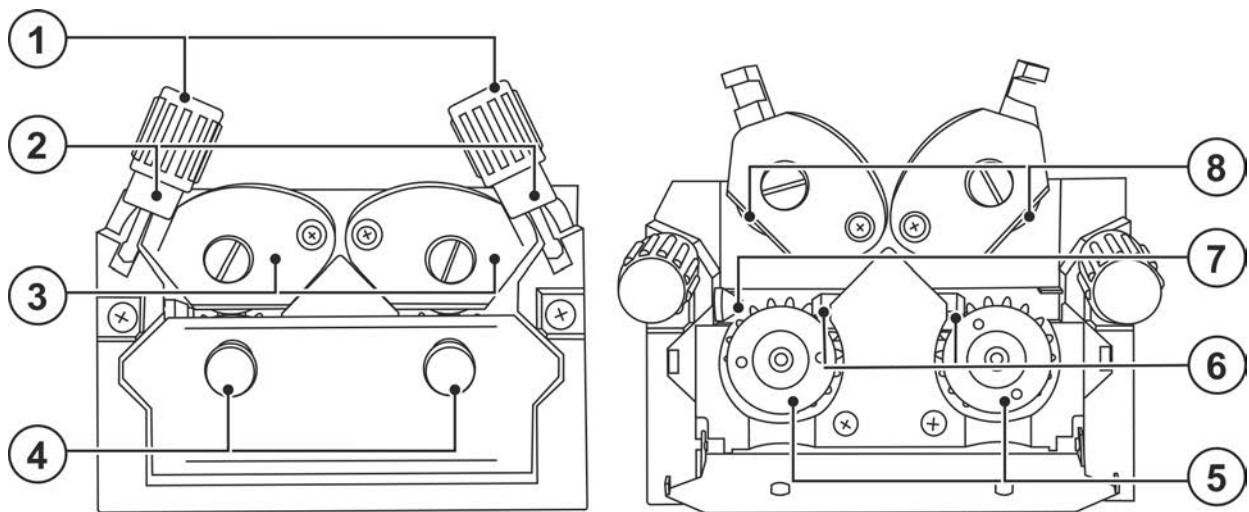

Figure 5-12

Item	Symbol	Description
1		Adjusting nut
2		Feed roll tensioner Fixing the clamping unit and setting the pressure.
3		Clamping unit
4		Knurled screw
5		Drive roller
6		Guide tube
7		Wire feed nipple
8		Pressure roller

- Extend and lay out the torch hose package.
- Unfasten pressure units and fold out (clamping units and pressure rollers will automatically flip upwards).
- Unwind welding wire carefully from the wire spool and insert through the wire inlet nipple over the drive roller grooves and the guide pipe into the capillary tube and Teflon core using guide pipe.
- Press the clamping element with the pressure roller back downwards and fold the wire units back up again (wire electrode should be in the groove on the drive roller).
- Set the contact pressure with the adjusting nuts of the pressure unit.
- Press the wire inching button until the wire electrode projects out of the welding torch.



#### 5.2.2.4 Spool brake setting

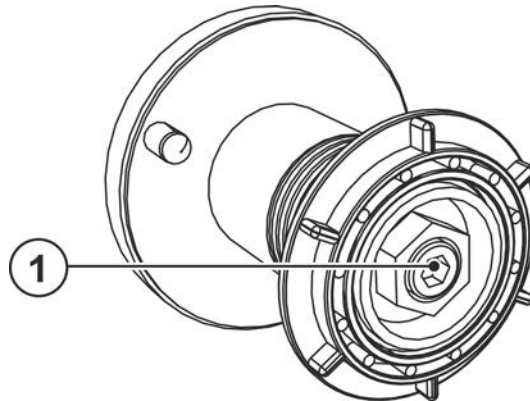

Figure 5-13

Item	Symbol	Description
1		<b>Allen screw</b> Securing the wire spool retainer and adjustment of the spool brake

- Tighten the Allen screw (8 mm) in the clockwise direction to increase the braking effect.

**Tighten the spool brake until the wire spool no longer turns when the wire feed motor stops but without it jamming during operation!**

#### 5.2.3 Definition of MIG/MAG welding tasks

This machine range features simple operation with a very wide range of functions.

- JOBs (welding tasks consisting of welding process, type of material, wire diameter and type of shielding gas) are pre-defined for all common welding tasks.
- Simple JOB selection from a list of pre-defined JOBs (sticker on the machine).
- The required process parameters are calculated by the system depending on the operating point specified (single-dial operation via wire speed rotary dial).
- Conventional welding task definition using wire speed and welding voltage is also possible.

**The welding task definition described below applies when defining MIG/MAG and cored wire welding tasks.**

**Pay attention to the signal light for the polarity setting!**

**It may be necessary to change the welding current polarity depending on the JOB selected or the welding process.**

- **Reconnect the polarity selection plug if necessary.**

## 5.2.4 Welding task selection

The settings for the respective welding parameters are defined by the different JOBS. The right JOB can be determined quickly with the JOB list > see 11.1 chapter.

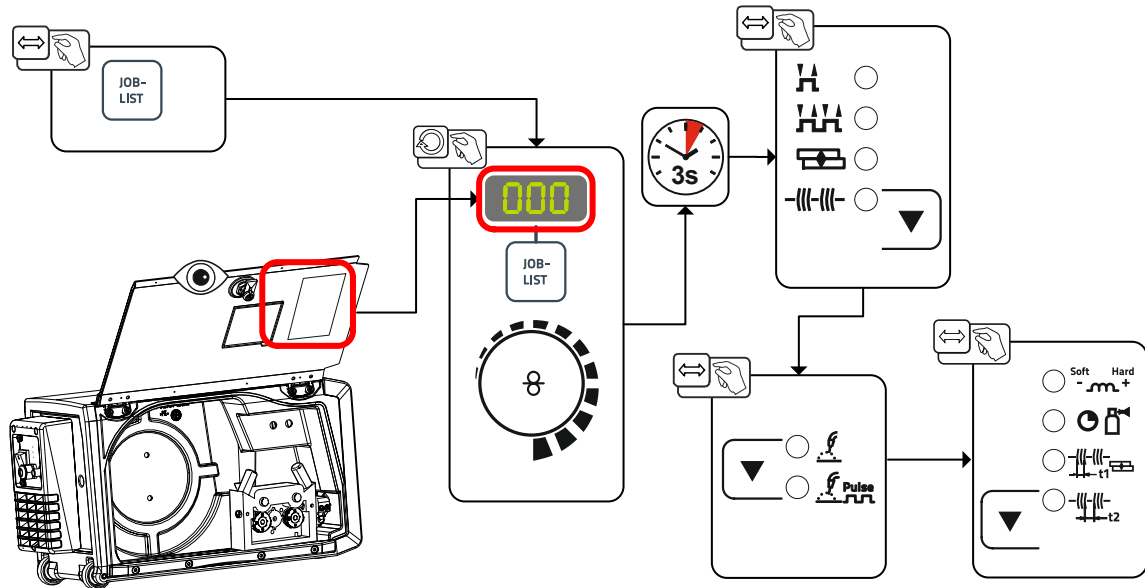

Figure 5-14

### Validity of the settings.

Spot time, pause time and wire feed speed settings apply to all JOBS. Throttling effect/dynamics, gas post-flow time, gas pre-flow time and wire burn-back correction are stored for each JOB individually.

Changes are stored permanently in the JOB that is currently selected.

If required, these parameter values can be reset to the factory settings > see 7.3 chapter.

## 5.2.5 Welding power (operating point)

### 5.2.5.1 Selecting the welding parameter display mode

The operating point (welding power) can be displayed or set as the welding current, material thickness or wire speed.

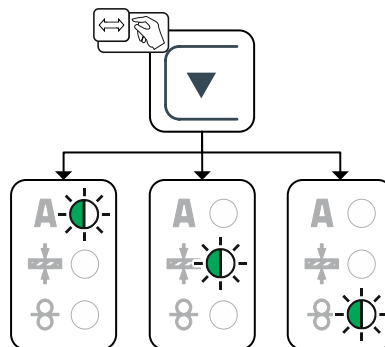

Figure 5-15

### 5.2.5.2 Operating point setting using material thickness

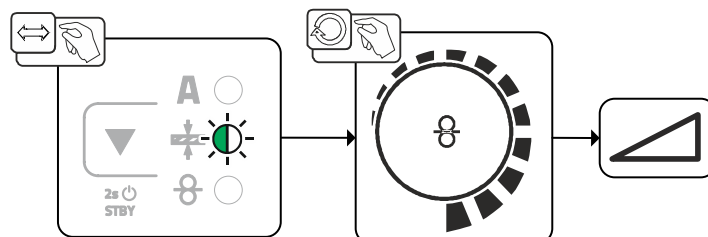

Figure 5-16

### 5.2.5.3 Arc length

Setting range: -5 V to +5 V

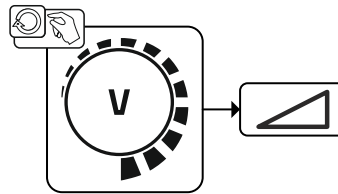

Figure 5-17

The basic settings are now completed. Other welding parameters have already been set optimally in the factory; they can, however, be modified to suit individual requirements.

### 5.2.6 Further welding parameters

- Preselection: Select a MIG/MAG JOB > see 5.2.4 chapter.

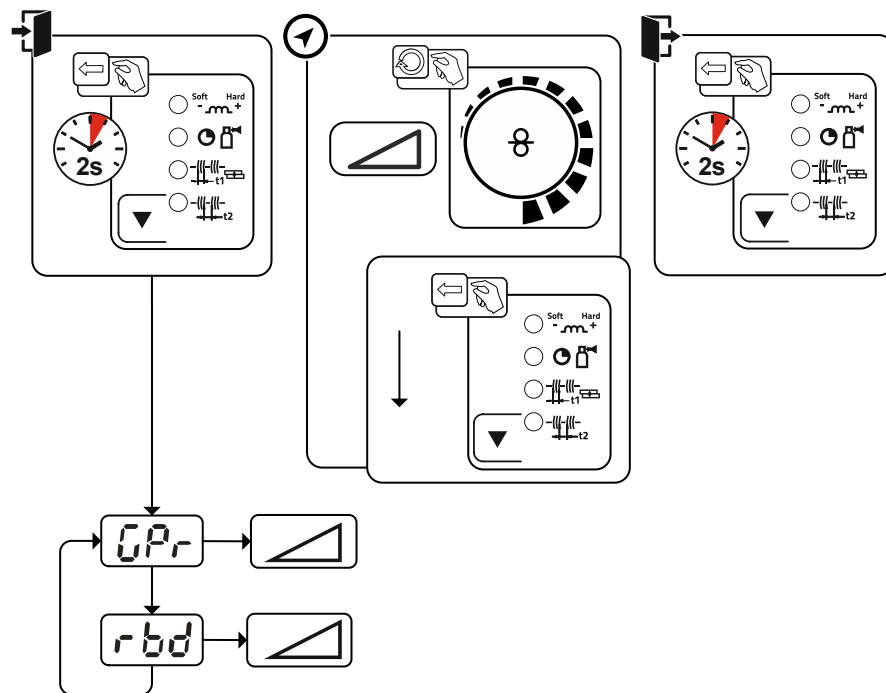















Figure 5-18

Display	Setting/selection
	Gas pre-flow time
	Burn-back correction

## 5.2.7 Operating modes (functional sequences)

### 5.2.7.1 Explanation of signs and functions

Symbol	Meaning
	Press torch trigger
	Release torch trigger
	Shielding gas flowing
	Welding output
	Wire electrode is being conveyed
	Wire creep
	Wire burn-back
	Gas pre-flows
	Gas post-flows
	Non-latched
	Latched
	Time
	Spot time
	Pause time

### 5.2.7.2 Automatic cut-out

Once the fault periods have elapsed, the automatic cut-out stops the welding process when it has been triggered by one of two states:

- During ignition  
5 s after the start of the welding process, no welding current flows (ignition error).
- During welding  
The arc is interrupted for more than 5 s (arc interruption).

Non-latched mode

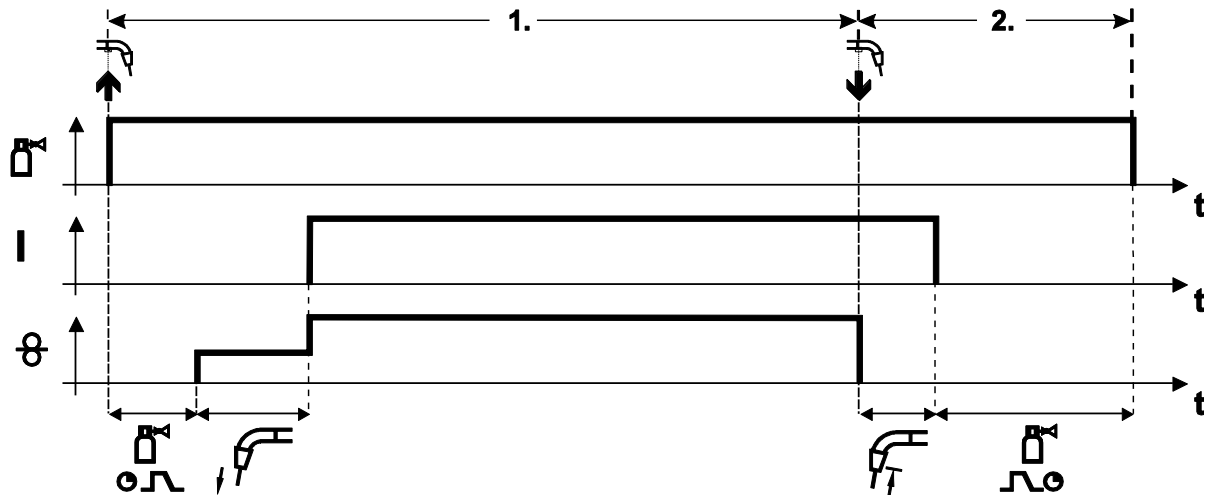

Figure 5-19

**Step 1**

- Press and hold torch trigger.
- Shielding gas is expelled (gas pre-flows).
- Wire feed motor runs at "creep speed".
- Arc ignites after the wire electrode makes contact with the workpiece; welding current flows.
- Change over to pre-selected wire speed.

**Step 2**

- Release torch trigger.
- WF motor stops.
- Arc is extinguished after the preselected wire burn-back time expires.
- Gas post-flow time elapses.

## Latched mode

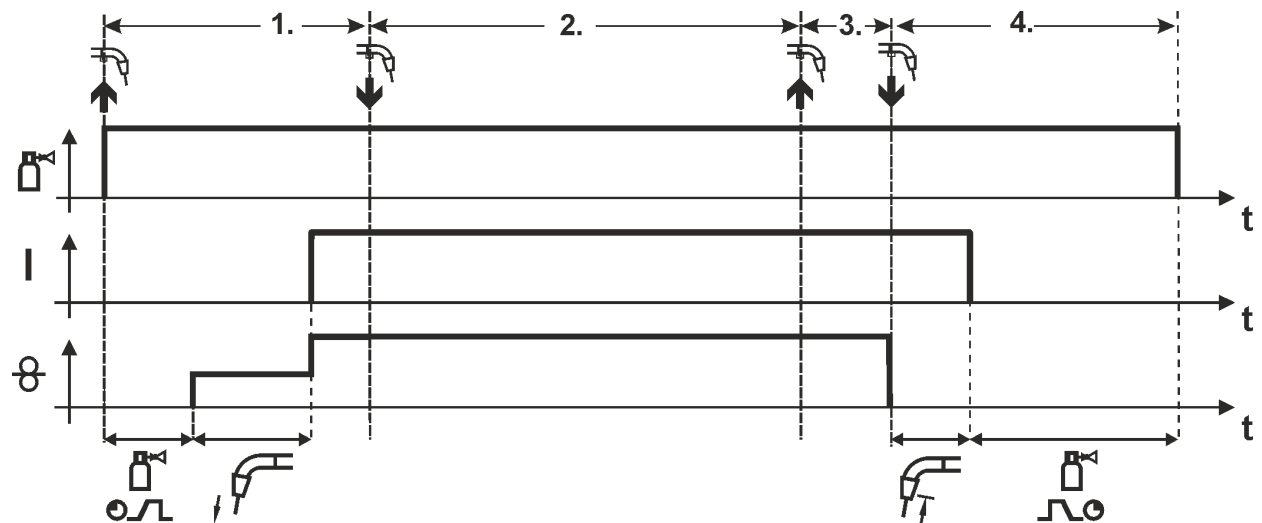

Figure 5-20

### 1. cycle

- Press and hold torch trigger
- Shielding gas is expelled (gas pre-flows)
- Wire feed motor runs at “creep speed”
- Arc ignites when the wire electrode makes contact with the workpiece  
Welding current flows
- Wire feed speed increases to the set nominal value

### 2. cycle

- Release torch trigger (no effect)

### 3. cycle

- Press torch trigger (no effect)

### 4. cycle

- Release torch trigger
- Wire feed motor stops
- Arc is extinguished after the pre-selected wire burn-back time elapses
- Gas post-flow time elapses

## Spot welding

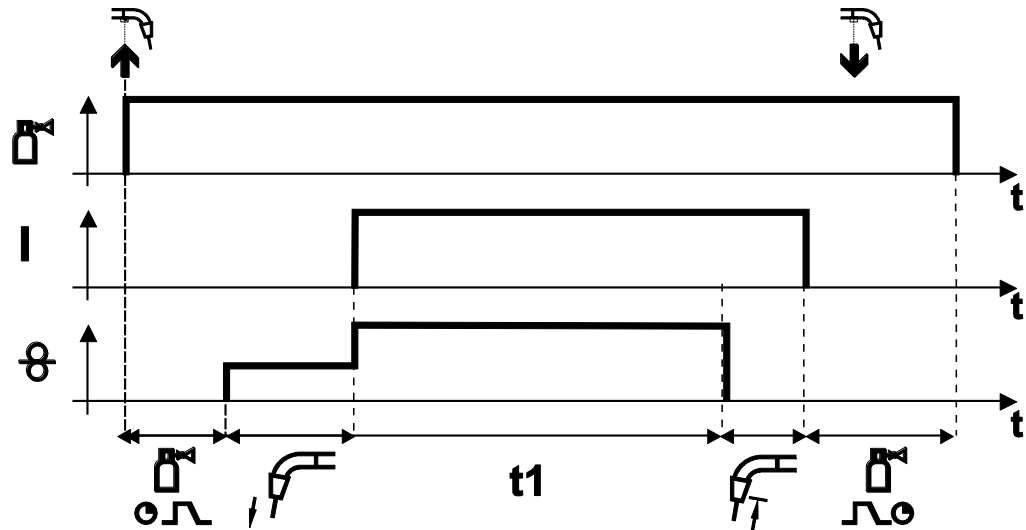

Figure 5-21

**Start**

- Press and hold torch trigger.
- Shielding gas is expelled (gas pre-flows).
- Arc ignites after the wire electrode makes contact with the workpiece at creep speed.
- Welding current flows.
- Wire feed speed increases to the set nominal value.
- The wire feed stop welding after the spot time elapses.
- Arc is extinguished after the wire burn-back time elapses.
- Gas post-flow time elapses.

**Premature termination**

- Release torch trigger.

## Interval

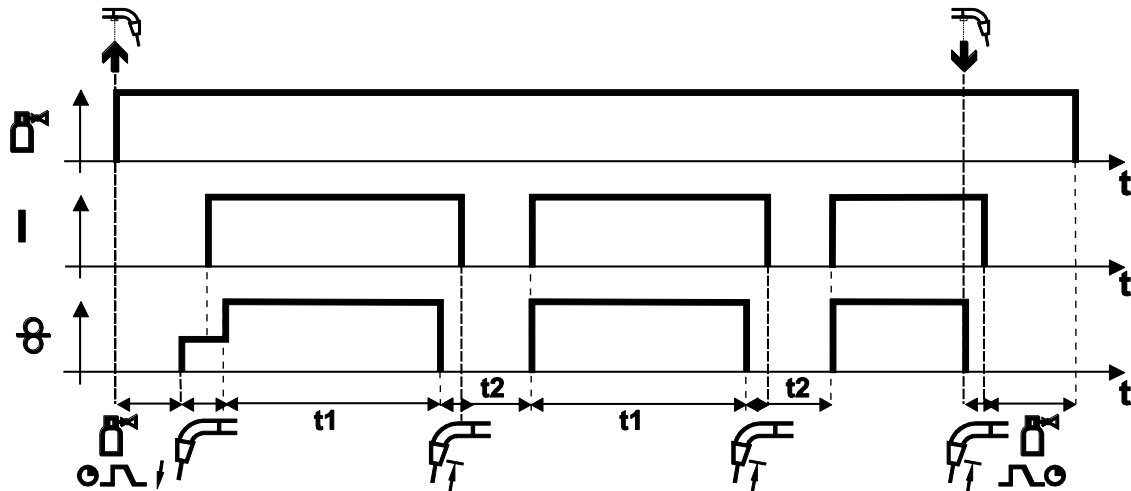

Figure 5-22

### Start

- Press and hold torch trigger.
- Shielding gas is expelled (gas pre-flows).

### Sequence

- Arc ignites after the wire electrode makes contact with the workpiece at creep speed.
- Welding current flows.
- Wire feed speed increases to the set nominal value.
- The wire feed stops after the spot time elapses.
- Arc is extinguished after the wire burn-back time elapses.
- The process is repeated when the pause time is over.

### End

- Release torch trigger, wire feed stops, arc is extinguished, gas post-flow time elapses.

**If the pause time is less than 3 s, wire creep only takes place in the first spot phase.**

When the torch trigger is released, the welding process is also ended even before the spot time elapses.

## 5.2.8 Conventional MIG/MAG Welding (GMAW non synergic)

You can only change the JOB number when no welding current is flowing.

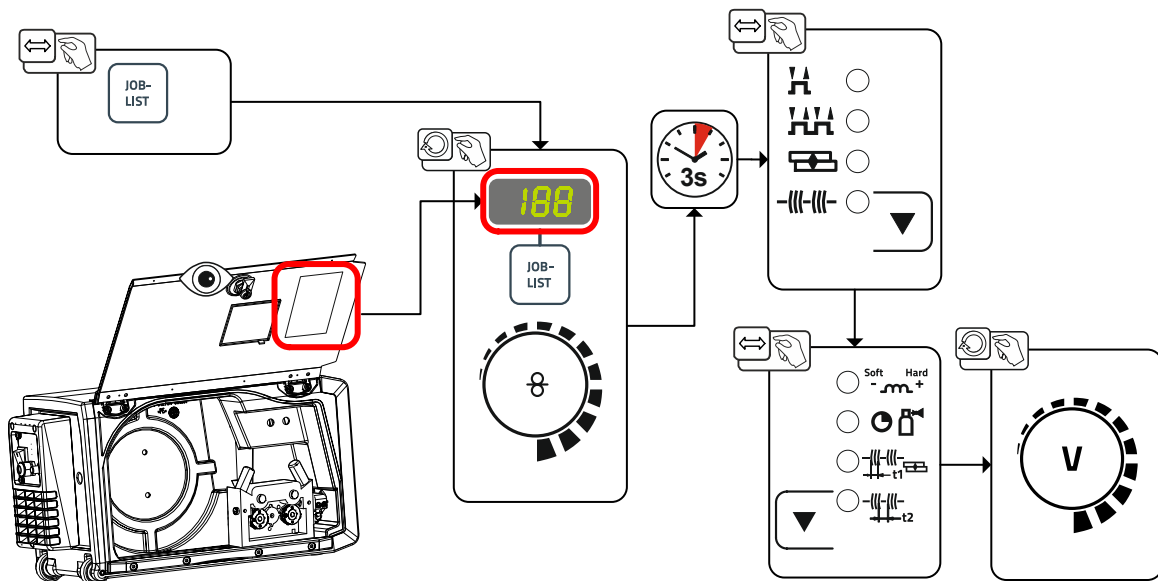

Figure 5-23



### 5.3 MMA welding

#### CAUTION



**Risk of crushing and burns!**

**When changing stick electrodes there is a risk of crushing and burns!**

- Wear appropriate and dry protective gloves.
- Use an insulated pair of tongs to remove the used stick electrode or to move welded workpieces.

#### 5.3.1 Connecting the electrode holder and workpiece lead

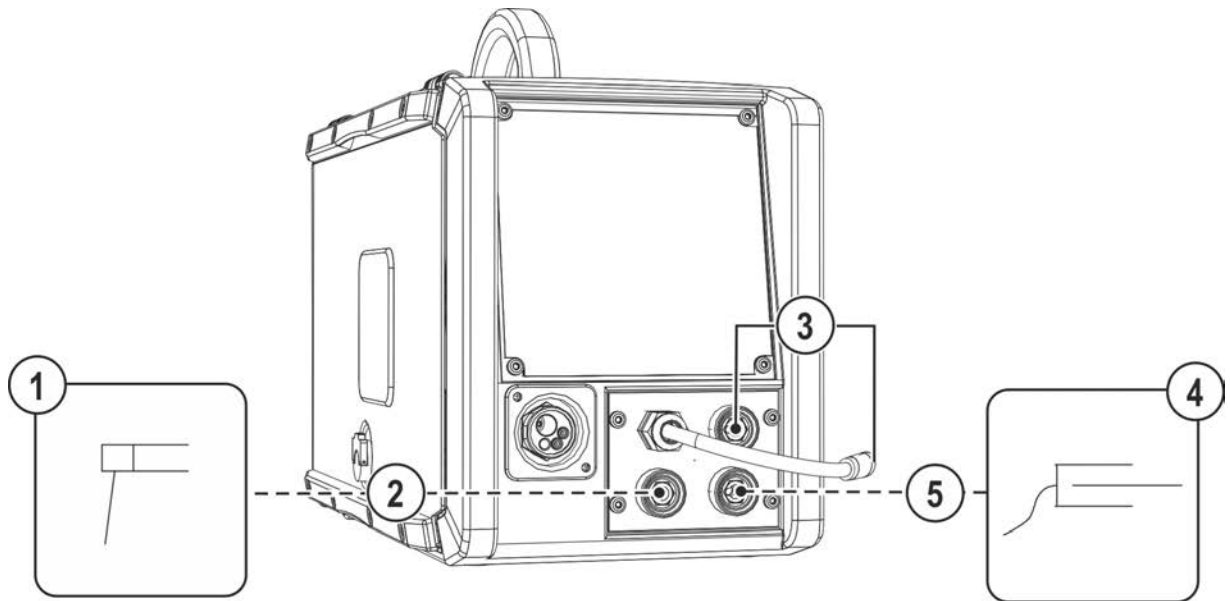

Figure 5-24

Item	Symbol	Description
1		<b>Electrode holder</b>
2		<b>Connection socket for "+" welding current</b> Electrode holder or workpiece lead connection
3		<b>Polarity selector plug, welding current cable</b> • Connect to the park socket.
4		<b>Workpiece</b>
5		<b>Connection socket, "-" welding current</b> Electrode holder or workpiece lead connection

- Insert the polarity selection plug in the park socket and lock in place by turning to the right.
- Insert the electrode holder plug and workpiece lead into the welding current socket depending on application and lock in place by turning to the right. The corresponding polarity will be based on the information of the electrode manufacturer on the electrode packaging.

## 5.3.2 Welding task selection

- Select MMA JOB 128 > see 11.1 chapter.

You can only change the JOB number when no welding current is flowing.

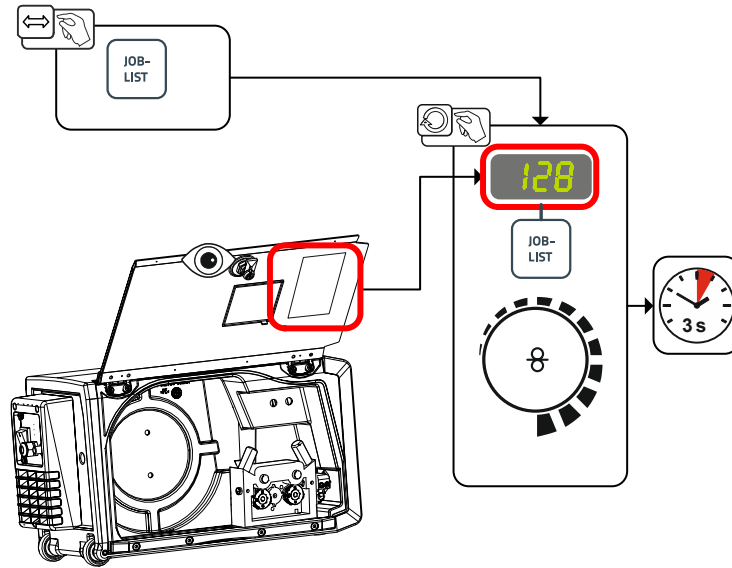

Figure 5-25

## 5.3.3 Arcforce

During the welding process, arcforce prevents the electrode sticking in the weld pool with increases in current. This makes it easier to weld large-drop melting electrode types at low current strengths with a short arc in particular.

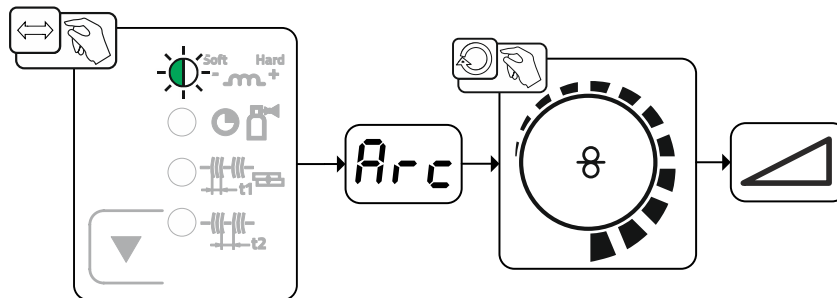

Figure 5-26

Display	Setting/selection
Arc	<b>Arcforce correction</b> <ul style="list-style-type: none"> <li>• Increase value &gt; harder arc</li> <li>• Decrease value &gt; softer arc</li> </ul>

## 5.3.4 Hotstart

The function hot start ensures a secure igniting of the arc and a sufficient heating to the still cold parent metal at the beginning of the welding process. The ignition takes place here with increased current (hot start current) over a certain time (hot start time).

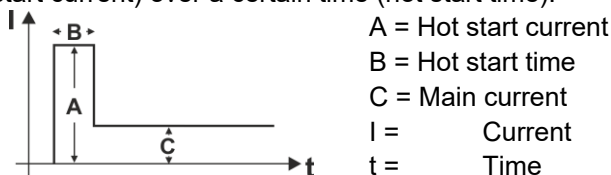

Figure 5-27

### 5.3.4.1 Hotstart settings

The setting ranges for the parameter values are summarised in the Parameter overview section > see 11.2 chapter.

- Select MMA JOB 128 > see 5.3.2 chapter.

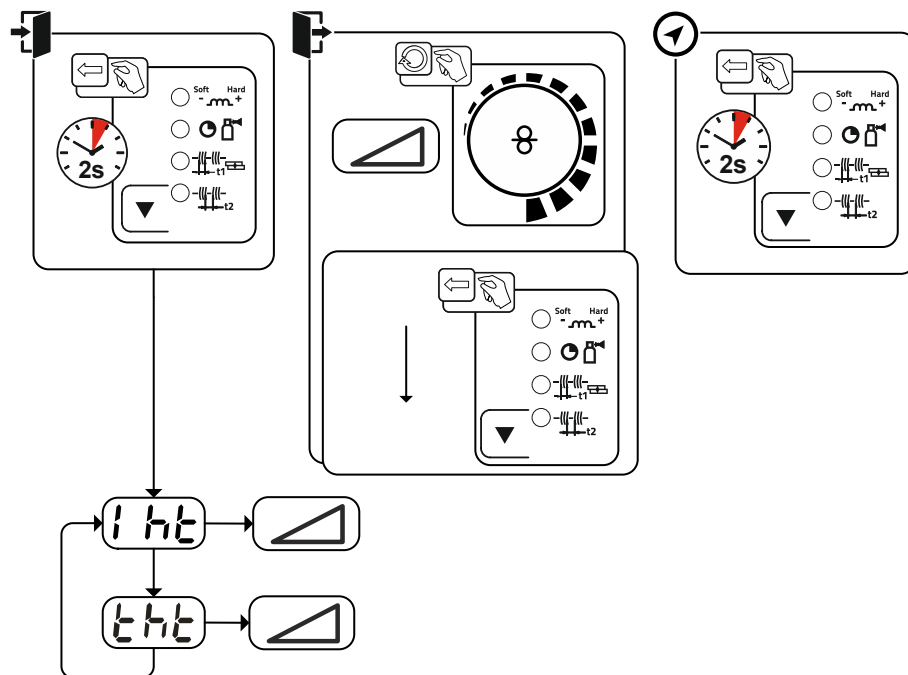
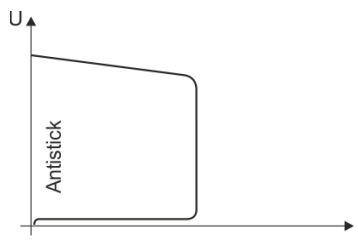

Figure 5-28

Display	Setting/selection
	Hotstart current
	Hotstart time

### 5.3.5 Antistick



**The Antistick feature prevents the electrode from annealing.**

Should the electrode stick despite the Arcforce feature, the machine automatically switches to the minimum current within approx. one second. This prevents the electrode from annealing. Check the welding current setting and correct for the welding task in hand.

Figure 5-29

## 5.4 TIG welding

### 5.4.1 Preparing the TIG welding torch

The TIG welding torch is to be equipped to suit the relevant welding task!

- Fit suitable tungsten electrodes and
- an appropriate shielding gas nozzle.
- Observe the operating instructions for the TIG welding torch!

## 5.4.2 Welding torch and workpiece line connection

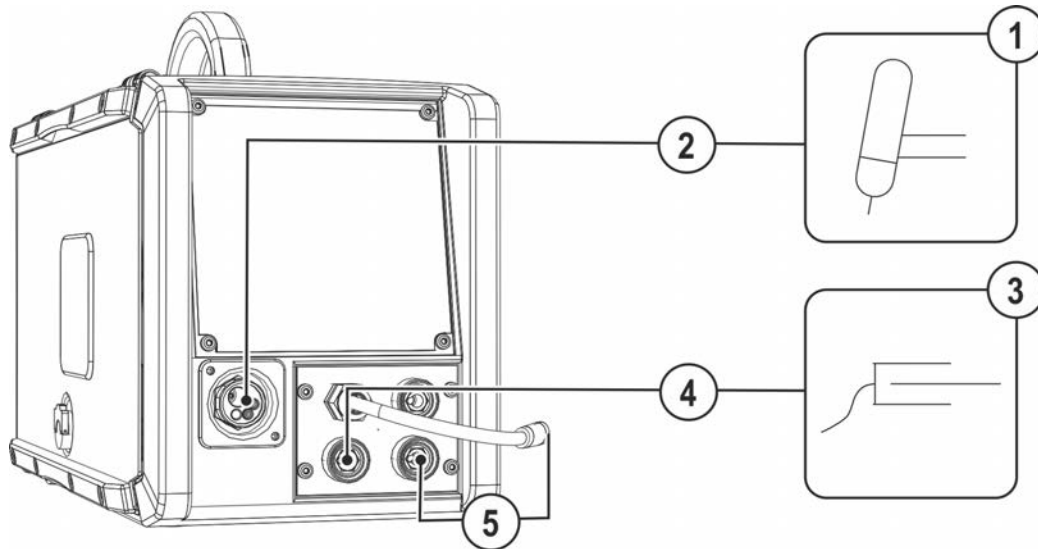

Figure 5-30

Item	Symbol	Description
1		<b>Welding torch</b>
2		<b>Welding torch connection (Euro torch connector)</b> Welding current, shielding gas and torch trigger integrated
3		<b>Workpiece</b>
4		<b>Connection socket, "+" welding current</b> • TIG welding: Workpiece connection
5		<b>Polarity selector plug, welding current cable</b> Internal welding current cable for central connection/welding torch. • Connection socket for "-" welding current

- Insert the central plug for the welding torch into the central connector and screw together with crown nut.
- Insert the polarity selection plug into the "-" welding current connection socket and lock in place by turning to the right.
- Insert the plug of the workpiece lead into the "+" welding current connection socket and lock in place by turning to the right.

**5.4.3 Welding task selection**

- Select TIG JOB 127.

You can only change the JOB number when no welding current is flowing.

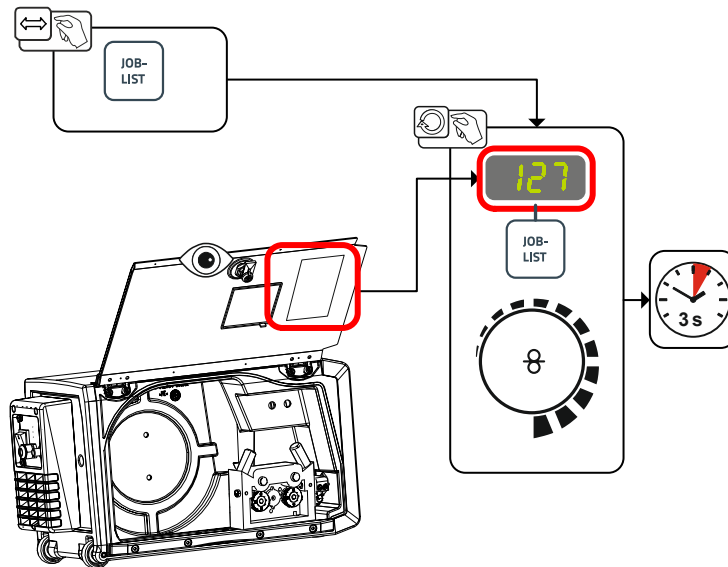

Figure 5-31

**5.4.4 Adjusting the gas post-flow time**

- Preselection: Select TIG JOB 127 > see 5.4.3 chapter.

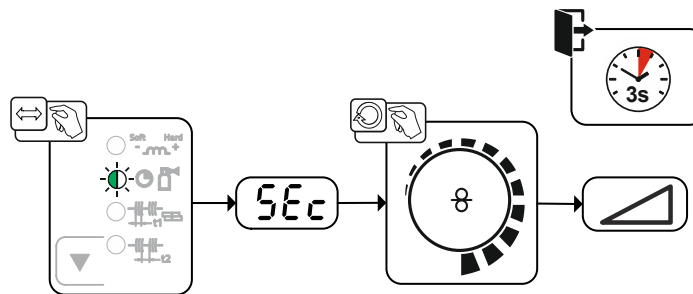

Figure 5-32

Display	Setting/selection
5Ec	Gas post-flow time

**5.4.5 Further welding parameters**

The setting ranges for the parameter values are summarised in the Parameter overview section > see 11.2 chapter.

- Preselection: Select TIG JOB 127 > see 5.4.3 chapter.

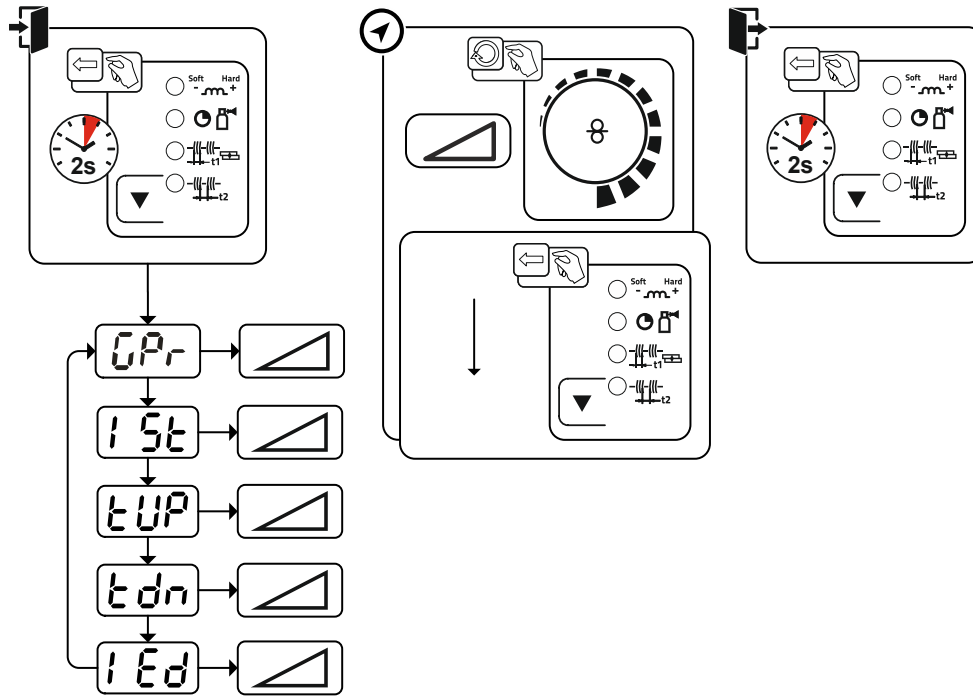







Figure 5-33

Display	Setting/selection
<b>GPr</b>	Gas pre-flow time
<b>15t</b>	Ignition current
<b>tUP</b>	Up-slope time
<b>tdn</b>	Down-slope time
<b>IEd</b>	End current

## 5.4.6 Operating modes (functional sequences)

### 5.4.6.1 Legend

Symbol	Meaning
	Press torch trigger
	Release torch trigger
I	Welding current
	Gas pre-flows
	Gas post-flows
	Non-latched
	Latched
t	Time
$t_{up}$	Upslope time
$t_{down}$	Downslope time
$I_{start}$	Ignition current
$I_{end}$	End-crater current

### 5.4.6.2 Automatic cut-out

Once the fault periods have elapsed, the automatic cut-out stops the welding process when it has been triggered by one of two states:

- During ignition  
5 s after the start of the welding process, no welding current flows (ignition error).
- During welding  
The arc is interrupted for more than 5 s (arc interruption).

## Non-latched mode

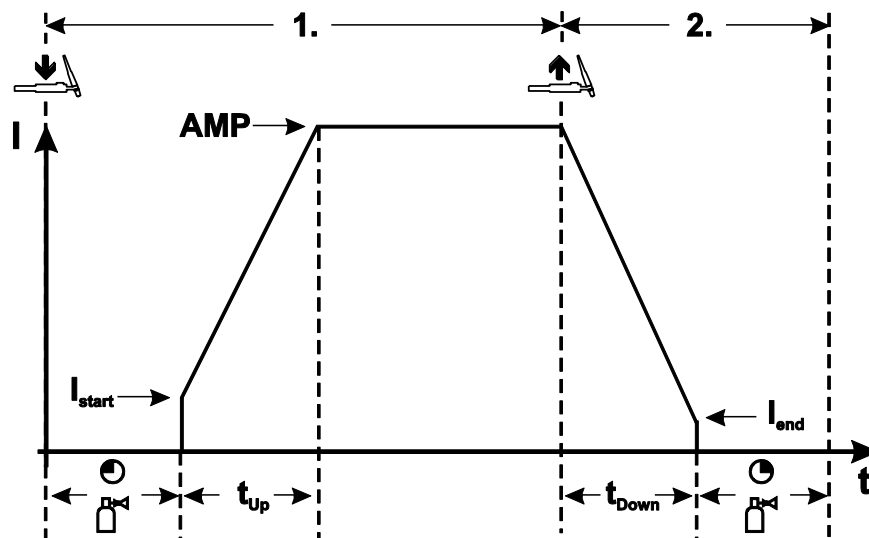

Figure 5-34

### 1st cycle

- Press and hold torch trigger.
- Shielding gas is expelled (gas pre-flows).

#### The arc is ignited using liftarc.

- The welding current flows with the value set for the starting current  $I_{start}$ .
- Welding current increases to the main current in the set upslope time.

### 2nd cycle

- Release torch trigger.
- The main current falls in the set downslope time to the end-crater current  $I_{end}$ .

#### If the torch trigger is pressed again during the downslope time, the welding current returns to the set main current!

- The main current reaches the end-crater current  $I_{end}$ , the arc extinguishes.
- Gas post-flow time elapses.



## Latched mode

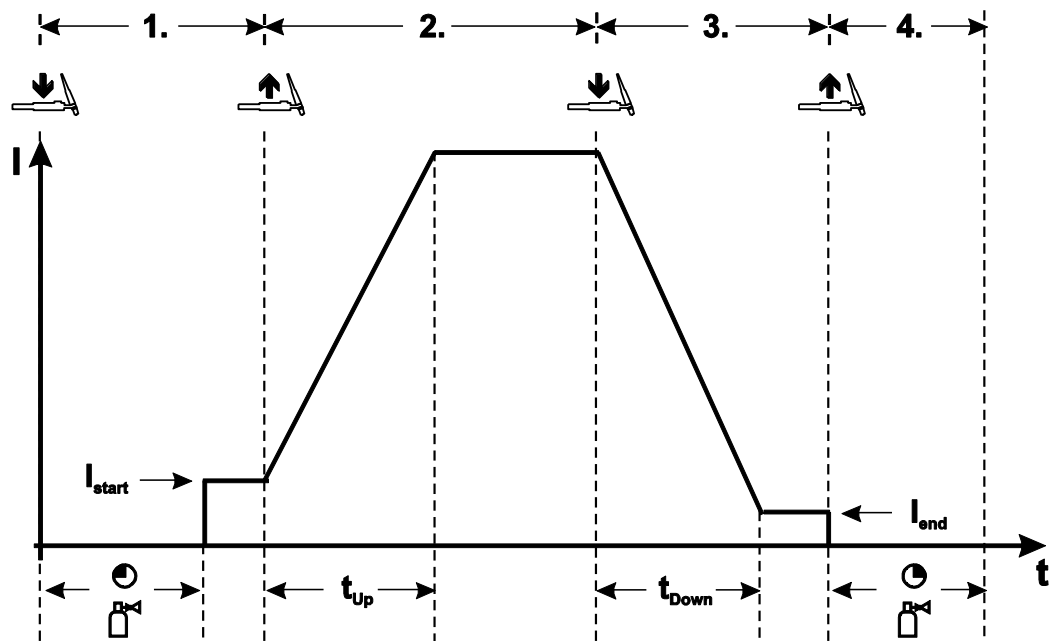

Figure 5-35

**1st cycle**

- Press and hold torch trigger.
- Shielding gas is expelled (gas pre-flows).

**The arc is ignited using liftarc.**

- The welding current flows with the value set for the starting current  $I_{start}$ .

**2nd cycle**

- Release torch trigger.
- Welding current increases to the main current in the set upslope time.

**3rd cycle**

- Press and hold torch trigger.
- The main current falls in the set downslope time to the end-crater current  $I_{end}$ .

**4th cycle**

- Release torch trigger, arc is extinguished.
- Gas post-flow time elapses.

**The welding process is terminated immediately if the torch trigger is released during the downslope time.**

The welding current drops to zero and the gas post-flow time begins.

### 5.4.7 Arc ignition

#### 5.4.7.1 Liftarc

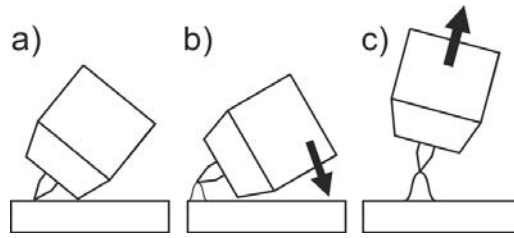

Figure 5-36

**The arc ignites through contact with the workpiece:**

- Carefully place the torch gas nozzle and tungsten electrode tip against the workpiece (lift arc current flows independent of the set main current)
- Angle the torch above the torch gas nozzle until the distance between electrode tip and workpiece is approx. 2–3 mm (arc ignites, current increases to the set main current).
- Lift the torch off and bring into normal position.

**Complete the welding task: Remove the torch from the workpiece so that the arc extinguishes.**

## 5.5 Machine configuration menu

### 5.5.1 Selecting, changing and saving parameters

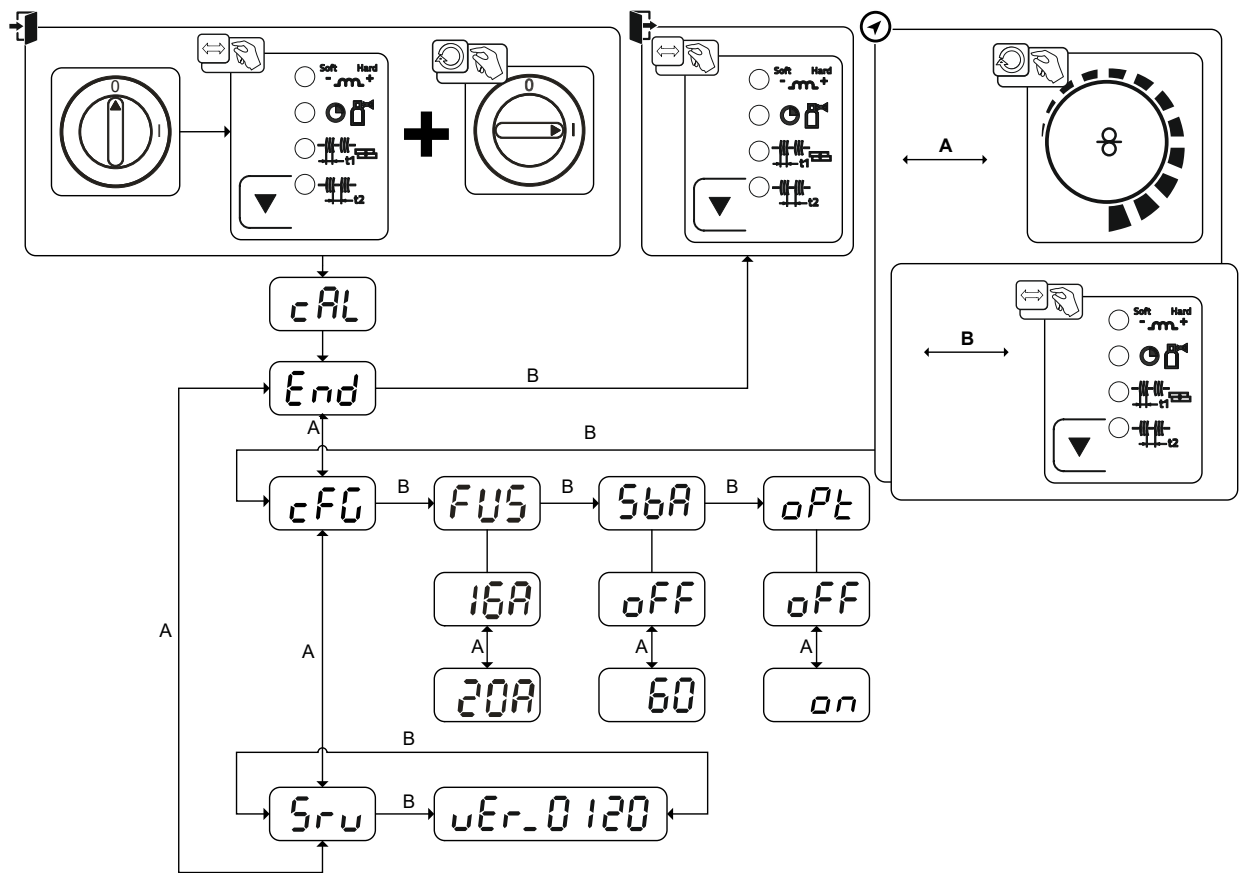

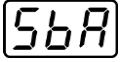

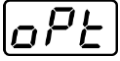

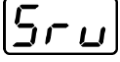



Figure 5-37

Display	Setting/selection
<b>cAL</b>	<b>Calibration</b> The machine will be calibrated for approx 2 seconds each time it is switched on.
<b>End</b>	<b>Exit the menu</b> Exit
<b>cFG</b>	<b>Machine configuration</b> Settings for machine functions and parameter display

Display	Setting/selection
	<b>Dynamic power adjustment</b> > see 7.5 chapter
	<b>Time-based power-saving mode</b> > see 5.6 chapter Time to activation of the power-saving mode in case of inactivity. Setting  = disabled or numerical value 5-60 min..
	<b>Arc detection for welding helmets (TIG)</b> Modulated waviness for better arc detection  ----- Function enabled  ----- Function disabled
	<b>Service menu</b> Any changes to the service menu should be agreed with the authorised service personnel.
	<b>Software version of the machine control</b> Version display

## 5.6 Power-saving mode (Standby)

You can activate the power-saving mode by either pressing the push-button > see 4.3 chapter for a prolonged time or by setting a parameter in the machine configuration menu (time-controlled power-saving mode  ) > see 5.5 chapter.

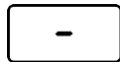

When power-saving mode is activated, the machine displays show the horizontal digit in the centre of the display only.

Pressing any operating element (e.g. turning a rotary knob) deactivates power-saving mode and the machine is ready for welding again.

## 6 Maintenance, care and disposal

### 6.1 General

#### **DANGER**



**Risk of injury due to electrical voltage after switching off!**

**Working on an open machine can lead to fatal injuries!**

**Capacitors are loaded with electrical voltage during operation. Voltage remains present for up to four minutes after the mains plug is removed.**

1. Switch off machine.
2. Remove the mains plug.
3. Wait for at least 4 minutes until the capacitors have discharged!

#### **WARNING**



**Incorrect maintenance, testing and repair!**

**Maintenance, testing and repair of the machine may only be carried out by skilled and qualified personnel. A qualified person is one who, because of his or her training, knowledge and experience, is able to recognise the dangers that can occur while testing welding power sources as well as possible subsequent damage, and who is able to implement the required safety procedures.**

Observe the maintenance instructions > see 6.2 chapter.

- In the event that the provisions of one of the below-stated tests are not met, the machine must not be operated again until it has been repaired and a new test has been carried out!

Repair and maintenance work may only be performed by qualified authorised personnel; otherwise the right to claim under warranty is void. In all service matters, always consult the dealer who supplied the machine. Return deliveries of defective equipment subject to warranty may only be made through your dealer. When replacing parts, use only original spare parts. When ordering spare parts, please quote the machine type, serial number and item number of the machine, as well as the type designation and item number of the spare part.

Under the specified ambient conditions and normal working conditions this machine is essentially maintenance-free and requires just a minimum of care.

Contamination of the machine may impair service life and duty cycle. The cleaning intervals depend on the ambient conditions and the resulting contamination of the machine. The minimum interval is every six months.

#### 6.1.1 Cleaning

- Clean the outer surfaces with a moist cloth (no aggressive cleaning agents).
- Purge the machine venting channel and cooling fins (if present) with oil- and water-free compressed air. Compressed air may overspeed and destroy the machine fans. Never direct the compressed air directly at the machine fans. Mechanically block the fans, if required.
- Check the coolant for contaminants and replace, if necessary.

#### 6.1.2 Dirt filter

When using a dirt filter, the cooling air throughput is reduced and the duty cycle of the machine is reduced as a result. The duty cycle decreases with the increasing contamination of the filter. The dirt filter must be removed at regular intervals and cleaned by blowing out with compressed air (depending on the level of soiling).

## **6.2 Maintenance work, intervals**

### **6.2.1 Daily maintenance tasks**

Visual inspection

- Mains supply lead and its strain relief
- Gas cylinder securing elements
- Check hose package and power connections for exterior damage and replace or have repaired by specialist staff as necessary!
- Gas tubes and their switching equipment (solenoid valve)
- Check that all connections and wearing parts are hand-tight and tighten if necessary.
- Check correct mounting of the wire spool.
- Wheels and their securing elements
- Transport elements (strap, lifting lugs, handle)
- Other, general condition

Functional test

- Operating, message, safety and adjustment devices (Functional test)
- Welding current cables (check that they are fitted correctly and secured)
- Gas tubes and their switching equipment (solenoid valve)
- Gas cylinder securing elements
- Check correct mounting of the wire spool.
- Check that all screw and plug connections and replaceable parts are secured correctly, tighten if necessary.
- Remove any spatter.
- Clean the wire feed rollers on a regular basis (depending on the degree of soiling).

### **6.2.2 Monthly maintenance tasks**

Visual inspection

- Casing damage (front, rear and side walls)
- Wheels and their securing elements
- Transport elements (strap, lifting lugs, handle)
- Check coolant tubes and their connections for impurities

Functional test

- Selector switches, command devices, emergency stop devices, voltage reducing devices, message and control lamps
- Check wire guide elements (wire feed roll holder, wire feed nipple, wire guide tube) for tight fit. Recommendation for replacing the wire feed roll holder (eFeed) after 2000 hours of operation, see replacement parts).
- Check coolant tubes and their connections for impurities
- Check and clean the welding torch. Deposits in the torch can cause short circuits and have a negative impact on the welding result, ultimately causing damage to the torch.

### **6.2.3 Annual test (inspection and testing during operation)**

A periodic test according to IEC 60974-4 "Periodic inspection and test" has to be carried out. In addition to the regulations on testing given here, the relevant local laws and regulations must also be observed.

For more information refer to the "Warranty registration" brochure supplied and our information regarding warranty, maintenance and testing at [www.ewm-group.com](http://www.ewm-group.com)!

## 6.3 Disposing of equipment



### Proper disposal!

The machine contains valuable raw materials, which should be recycled, and electronic components, which must be disposed of.

- Do not dispose of in household waste!
- Observe the local regulations regarding disposal!
- According to European provisions (Directive 2012/19/EU on Waste of Electrical and Electronic Equipment), used electric and electronic equipment may no longer be placed in unsorted municipal waste. It must be collected separately. The symbol depicting a waste container on wheels indicates that the equipment must be collected separately.  
This machine has to be disposed of, or recycled, in accordance with the waste separation systems in use.
- According to German law (law governing the distribution, taking back and environmentally correct disposal of electric and electronic equipment (ElektroG)), used machines are to be placed in a collection system separate from unsorted municipal waste. The public waste management utilities (communities) have created collection points at which used equipment from private households can be disposed of free of charge.
- Information about returning used equipment or about collections can be obtained from the respective municipal administration office.
- In addition to this, returns are also possible throughout Europe via EWM sales partners.

## 7 Rectifying faults

All products are subject to rigorous production checks and final checks. If, despite this, something fails to work at any time, please check the product using the following flowchart. If none of the fault rectification procedures described leads to the correct functioning of the product, please inform your authorised dealer.

### 7.1 Checklist for rectifying faults

**The correct machine equipment for the material and process gas in use is a fundamental requirement for perfect operation!**

Legend	Symbol	Description
	↗	Fault/Cause
	✘	Remedy

#### Collective interference signal light illuminates

- ↗ Excess temperature, welding machine
  - ✘ Allow the machine to cool down whilst still switched on
- ↗ Welding current monitoring device triggered (stray welding currents flowing across the protective earth). The error must be reset by switching the machine off and on again.
  - ✘ Welding wire is touching electrically conductive casing parts (check wire guide, has the welding wire sprung off the wire spool?).
  - ✘ Check for a correct mounting of the welding lead. Fit the feeder clamp of the welding lead as close as possible to the arc.

#### Excess temperature signal light illuminates

- ↗ Excess temperature, welding machine
  - ✘ Allow the machine to cool down whilst still switched on

#### Functional errors

- ↗ Mains fuse triggers - unsuitable mains fuse
  - ✘ Set up recommended mains fuse > see 8 chapter.
- ↗ Machine does not start up after switching on (device fan and possibly coolant pump have no function).
  - ✘ Connect the control cable of the wire feeder.
- ↗ All machine control signal lights are illuminated after switching on
- ↗ No machine control signal light is illuminated after switching on
- ↗ No welding power
  - ✘ Phase failure > check mains connection (fuses)
- ↗ Machine restarts continuously
- ↗ Wire feeder without function
- ↗ System does not start up
  - ✘ Make control lead connections and check that they are fitted correctly.
- ↗ Loose welding current connections
  - ✘ Tighten power connections on the torch and/or on the workpiece
  - ✘ Properly fasten the contact tip and contact tip holder.

## Wire feed problems

- ✓ Contact tip blocked
  - ✘ Clean, spray with anti-spatter spray and replace if necessary
- ✓ Setting the spool brake > see 5.2.2.4 chapter
  - ✘ Check settings and correct if necessary
- ✓ Setting pressure units > see 5.2.2.3 chapter
  - ✘ Check settings and correct if necessary
- ✓ Worn wire rolls
  - ✘ Check and replace if necessary
- ✓ Kinked hose packages
  - ✘ Extend and lay out the torch hose package
- ✓ Wire guide core or spiral is dirty or worn
  - ✘ Clean core or spiral; replace kinked or worn cores

## Mains fuse triggers

- ✓ Mains fuse triggers - unsuitable mains fuse
  - ✘ Set up recommended mains fuse > see 8 chapter.



## 7.2 Error messages (power source)

A welding machine error is indicated by the collective fault signal lamp (A1) lighting up and an error code (see table) being displayed in the machine control display. In the event of a machine error, the power unit shuts down.

- If multiple errors occur, these are displayed in succession.
- Document machine errors and inform service staff as necessary.

Error message	Possible cause	Remedy
E 0	Start signal set in the event of errors	Do not press the torch trigger or the foot-operated remote control
E 4	Temperature error	Allow the machine to cool down
E 5	Mains overvoltage	Switch off the machine and check the mains voltage
E 6	Mains undervoltage	
E 7	Electronics error	Switch the machine off and on again.
E 9	Secondary overvoltage	If the error persists, notify service department
E12	Voltage reduction error (VRD)	
E13	Electronics error	
E14	Adjustment error in current recording	Switch off the machine, place the electrode holder in an insulated position and switch the machine back on. If the error persists, notify service department
E15	Error in one of the electronics supply voltages	Switch the machine off and on again. If the error persists, notify service department
E23	Temperature error	Allow the machine to cool down
E32	Electronics error	Switch the machine off and on again. If the error persists, notify service department
E33	Adjustment error in voltage recording	Switch off the machine, place the electrode holder in an insulated position and switch the machine back on. If the error persists, notify service department
E34	Electronics error	Switch the machine off and on again. If the error persists, notify service department
E37	Temperature error	Allow the machine to cool down
E40	Motor fault	Check wire feed mechanism, switch the machine off and on again, inform the service department if the fault persists.
E51	Earth fault (PE error)	Connection between welding wire and machine casing
E55	Failure of a mains phase	Switch off the machine and check the mains voltage
E58	Short circuit in welding circuit	Switch off the machine and check welding current leads for correct installation, e.g. by placing the electrode holder in an insulated position; detach current lead from degaussing.

## 7.3 Resetting welding parameters to the factory settings

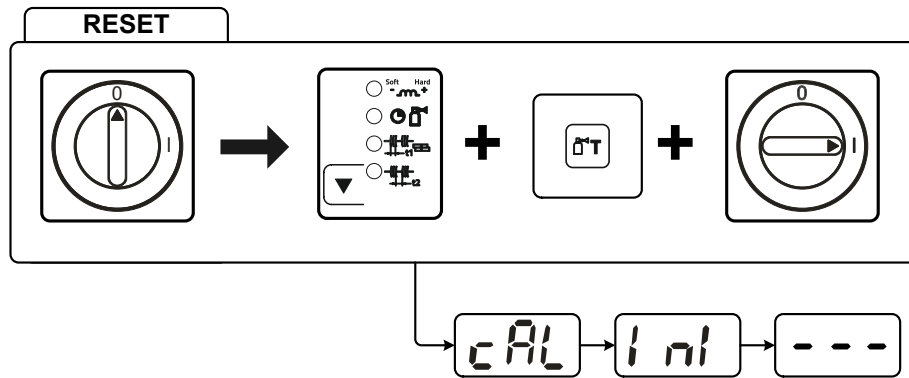

Figure 7-1

Display	Setting/selection
	<b>Calibration</b> The machine will be calibrated for approx 2 seconds each time it is switched on.
	<b>Initialising</b> Keep the push-button pressed until  is shown on the display.

## 7.4 Display machine control software version

The query of the software versions only serves to inform the authorised service staff. It is available in the machine configuration menu > see 5.5 chapter.

## 7.5 Dynamic power adjustment

**This requires use of the appropriate mains fuse.**

**Observe mains fuse specification > see 8 chapter!**

The dynamic power adjustment automatically adjusts the welding performance to an uncritical level for the fuse.

The dynamic power adjustment can be set in two increments in the machine configuration menu using parameter "FUS": 20 A, 16 A > see 5.5 chapter.

The currently selected value will be shown on the "cal" section of the display for three seconds after the machine has been switched on.

## 8 Technical data

### 8.1 Picomig 180 puls TKG

Performance specifications and guarantee only in connection with original spare and replacement parts!

	MIG/MAG	TIG	MMA
Welding current (I <sub>2</sub> )	5 A to 180 A		5 A to 150 A
Welding voltage according to standard (U <sub>2</sub> )	14,3 V to 23,0 V	10,2 V to 17,2 V	20,2 V to 26,0 V
Duty cycle DC at 40° C <sup>[1]</sup>	180 A (25 %) 120 A (60 %) 100 A (100 %)	180 A (30 %) 140 A (60 %) 120 A (100 %)	150 A (35 %) 110 A (60 %) 100 A (100 %)
Open circuit voltage (U <sub>0</sub> )	80 V		
Mains voltage (Tolerance)	1 x 230 V (-40 % to +15 %)		
Frequency	50/60 Hz		
mains fuse <sup>[2]</sup>	1 x 16 A		
Mains connection cable	H07RN-F3G2,5		
max. Connected load (S <sub>1</sub> )	5,9 kVA	4,4 kVA	5,5 kVA
Generator rating (Rec.)	8,0 kVA		
Cos φ / efficiency	0,99 / 86 %		
Protection class / Overvoltage category	I / III		
Contamination level	3		
Insulation class / protection classification	H / IP 23		
Residual current circuit breaker	Type B (recommended)		
Noise level <sup>[3]</sup>	<70 dB(A)		
Ambient temperature	-25 °C to +40 °C		
Machine cooling / Torch cooling	Fan (AF) / gas		
Wire feed speed	1 m/min to 15m/min		
Factory-installed roll equipment	0,8/1,0 mm for steel wire		
Drive	4 rollers (37 mm)		
Wire spool diameter	Standardised wire spools up to 200 mm		
Welding torch connection	Euro torch connector		
Workpiece lead (min.)	25 mm <sup>2</sup>		
EMC class	A		
Safety marking	☐ / CE / EAC		
Standards used	See declaration of conformity (appliance documents)		
Dimensions (l x b x h)	559 x 276 x 340 mm / 22.0 x 10.9 x 13.4 inch		
Weight	16,0 kg / 35.3 lb.		

<sup>[1]</sup> Load cycle: 10 min. (60 % DC  $\pm$  6 min. welding, 4 min. pause)

<sup>[2]</sup> Safety fuses are recommended DIAZED xxA gG. When using automatic cutouts, the "C" trigger characteristic must be used.

<sup>[3]</sup> Noise level during idle mode and operation under standard load according to IEC 60974- 1 at the maximum operating point.

## 9 Accessories

Performance-dependent accessories like torches, workpiece leads, electrode holders or intermediate hose packages are available from your authorised dealer.

### 9.1 General accessories

Type	Designation	Item no.
ADAP CEE16/SCHUKO	Earth contact coupling/CEE16A plug	092-000812-00000
DM 842 Ar/CO2 230bar 30l D	Pressure regulator with manometer	394-002910-00030
G1 G1/4 R 3M	Gas hose	094-000010-00003
ADAPTER EZA --> DINSE-ZA	Adapter for welding torches with Dinse connector to Euro central connector, on the machine	094-016765-00000

### 9.2 Options

Type	Designation	Item no.
ON Filter T.0005	Retrofit option, dirt filter for air inlet	092-002553-00000
ON Trolley Picomig	Trolley Picomig 180 with holder for 300 mm wire spool	092-000312-00000
ON CS T.005/TG.0003/D.0002	Crane suspension for Picomig 180 / 185 D3 / 305 D3, Phoenix and Taurus 355 compact, drive 4	092-002549-00000

### 9.3 Transport system

Type	Designation	Item no.
Trolley 35-1	Transport vehicle	090-008629-00000

## 10 Replaceable parts



*The manufacturer's warranty becomes void if non-genuine parts are used!*

- *Only use system components and options (power sources, welding torches, electrode holders, remote controls, spare parts and replacement parts, etc.) from our range of products!*
- *Only insert and lock accessory components into the relevant connection socket when the machine is switched off.*

### 10.1 Wire feed rollers

#### 10.1.1 Wire feed rollers for steel wire

Type	Designation	Item no.
FE 2DR4R 0,6+0,8	Drive rollers, 37 mm, steel	092-000839-00000
FE 2DR4R 0,8+1,0	Drive rollers, 37 mm, steel	092-000840-00000
FE 2DR4R 0,9+1,2	Drive rollers, 37 mm, steel	092-000841-00000
FE 2DR4R 1,0+1,2	Drive rollers, 37 mm, steel	092-000842-00000
FE 2DR4R 1,2+1,6	Drive rollers, 37 mm, steel	092-000843-00000
FE/AL 2GR4R SF	Pressure rollers, smooth, 37 mm	092-000414-00000

#### 10.1.2 Wire feed rollers for aluminium wire

Type	Designation	Item no.
AL 4ZR4R 0,8+1,0	Twin rollers, 37 mm, for aluminium	092-000869-00000
AL 4ZR4R 1,0+1,2	Twin rollers, 37 mm, for aluminium	092-000848-00000
AL 4ZR4R 1,2+1,6	Twin rollers, 37 mm, for aluminium	092-000849-00000
AL 4ZR4R 2,4+3,2	Twin rollers, 37 mm, for aluminium	092-000870-00000

#### 10.1.3 Wire feed rollers for cored wire

Type	Designation	Item no.
ROE 2DR4R 0,8/0,9+0,8/0,9	Drive rollers, 37 mm, cored wire	092-000834-00000
ROE 2DR4R 1,0/1,2+1,4/1,6	Drive rollers, 37 mm, cored wire	092-000835-00000
ROE 2DR4R 1,4/1,6+2,0/2,4	Drive rollers, 37 mm, cored wire	092-000836-00000
ROE 2DR4R 2,8+3,2	Drive rollers, 37 mm, cored wire	092-000837-00000
ROE 2GR4R	Pressure rollers, knurled, 37mm	092-000838-00000

## 10.1.4 Conversion kit

Type	Designation	Item no.
URUE VERZ>UNVERZ FE/AL 4R SF	Conversion kit, 37mm, 4-roller drive on non-toothed rollers (steel/aluminium)	092-000415-00000
URUE ROE 2DR4R 0,8/0,9+0,8/0,9 SF	Conversion kit, 37 mm, 4-roller drive for cored wire	092-000410-00000
URUE ROE 2DR4R 1,0/1,2+1,4/1,6 SF	Conversion kit, 37 mm, 4-roller drive for cored wire	092-000411-00000
URUE ROE 2DR4R 1,4/1,6+2,0/2,4 SF	Conversion kit, 37 mm, 4-roller drive for cored wire	092-000412-00000
URUE ROE 2DR4R 2,8+3,2 SF	Conversion kit, 37 mm, 4-roller drive for cored wire	092-000413-00000
URUE AL 4ZR4R 0,8+1,0 SF	Conversion kit, 37 mm, 4-roller drive for aluminium	092-002268-00000
URUE AL 4ZR4R 1,0+1,2 SF	Conversion kit, 37 mm, 4-roller drive for aluminium	092-002266-00000
URUE AL 4ZR4R 1,2+1,6 SF	Conversion kit, 37 mm, 4-roller drive for aluminium	092-002269-00000
URUE AL 4ZR4R 2,4+3,2 SF	Conversion kit, 37 mm, 4-roller drive for aluminium	092-002270-00000

<b>Verschleißteile</b> <b>4 Rollen-Antrieb</b> <b>Ø = 37mm</b>		St= Stahl Al= Aluminium CrNi= Edelstahl Cu= Kupfer	<b>Wear parts</b> <b>4-Roller drive system</b> <b>Ø = 37mm</b>
<b>V-Nut: St-, CrNi-, Cu-Draht</b> „Standard V-Nut“, oben unverzahnt und glatt, Rollenbezeichnung: „1,0“		<b>V-groove: St-, CrNi-, Cu wire</b> "Standard V-groove", on the top ungeared and plane, rolls description: "1,0"	
<b>Antriebsrollen- Ø (b):</b> <b>Drive rolls- Ø (b):</b> 0,6 + 0,8 0,8 + 1,0 0,9 + 1,2 1,0 + 1,2 1,2 + 1,6	<b>Ersatzset:</b> <b>Spare set:</b> 092-000839-00000 092-000840-00000 092-000841-00000 092-000842-00000 092-000843-00000		
Gegendruckrollenset (a) <i>Set of counter pressure rolls (a)</i> 092-000414-00000 Umrüstung verzahnt → unverzahnt: <i>conversion geared → ungeared:</i> 092-000415-00000			
<b>U-Nut: Al-, Cu-Draht</b> „Option U-Nut“, oben verzahnt, Rollenbezeichnung: „1,0 A2“		<b>U-groove: Al-, Cu wire</b> "Option U-groove", on the top geared-twin rolls, rolls description: "1,0 A2"	
<b>Antriebsrollen- Ø (a+b):</b> <b>Drive rolls- Ø (a+b):</b> 0,8 + 1,0 1,0 + 1,2 1,2 + 1,6 2,4 + 3,2	<b>Ersatzset:</b> <b>Spare set:</b> 092-000869-00000 092-000848-00000 092-000849-00000 092-000870-00000	<b>Umrüstset:</b> <b>Conversion set:</b> 092-002268-00000 092-002266-00000 092-002269-00000 092-002270-00000	
<b>U-Nut gerändelt: Füll-/Röhrchendraht</b> „Option U-Nut gerändelt“, oben verzahnt, ohne Nut gerändelt, Rollenbezeichnung: „1,0-1,2 R“		<b>knurled U-groove: Cored wire</b> "Option knurled U-groove", on the top geared, without knurled groove, rolls description: "1,0-1,2 R"	
<b>Antriebsrollen- Ø (b):</b> <b>Drive rolls- Ø (b):</b> 0,8 / 0,9 + 0,8 / 0,9 1,0 / 1,2 + 1,4 / 1,6 1,4 / 1,6 + 2,0 / 2,4 2,8 + 3,2	<b>Ersatzset:</b> <b>Spare set:</b> 092-000834-00000 092-000835-00000 092-000836-00000 092-000837-00000	<b>Umrüstset:</b> <b>Conversion set:</b> 092-000410-00000 092-000411-00000 092-000412-00000 092-000413-00000	
Gegendruckrollenset (a): <i>Set of counterpressure rolls (a):</i> 092-000838-00000			

Figure 10-1

# 11 Appendix

## 11.1 JOB-List

We recommend using the characteristics for 1.0-mm solid wire electrodes also for the 0.9-mm solid wire electrodes.

		<input checked="" type="checkbox"/> Pulse/ Standard	<input type="checkbox"/> Standard	JOB-LIST			
		Pulse only in Picomig puls Version					
● Massivdraht / Solid Wire	 Material	 Gas %	Ø Wire				
			0,6	0,8	1,0	1,2	
				Job-Nr.			
	SG2/3 G3/4 Si1	CO <sub>2</sub> 100 / C1	176	1	3	4	
		Ar80 - 90 / M21	175	6	8	9	
	CrNi	Ar91 - 99 / M12 - M13		34	35		
		Ar/He / I3		42	43		
	CuSi Löten / Brazing	Ar100 / I1		114	115	116	
		Ar91 - 99 / M12 - M13		110	111	112	
	AlMg	Ar100 / I1		74	75	76	
AlSi	Ar100 / I1		82	83	84		
Al99	Ar100 / I1		90	91	92		
● Fülldraht / Flux-Cored Wire	 Material	 Gas %	Ø Wire				
			0,9	1,0	1,1	1,2	
				Job-Nr.			
	E71T-11	Self-Shielded	172		171	170	
	E71T-1M Rutile	Ar80-90 / M21		242			
E70TC Metal	Ar80-90 / M21		237				
GMAW non synergic			188				
WIG / TIG			127				
E-Hand / MMA			128				

Figure 11-1

MIG/MAG pulse arc welding can be selected with JOBS 6, 34, 42, 74, 75, 76, 82, 83, 84, 90, 91, 110, 111, 114 and 115. If an attempt is made to set another JOB to pulse, "noP" = "no Pulse" appears briefly on the display and the machine is reset to default.

## 11.2 Parameter overview – setting ranges

Welding data display (3-digit)	Parameters/function	Setting range			
		Standard (ex works)	Min.	Max.	Unit

MIG/MAG				
$\overline{GPr}$	Gas pre-flow time	0,2	0,0 - 20,0	s
$\overline{dYn}$	Dynamic correction	0	-40 - 40	
$\overline{SEc}$	Gas post-flow time	0,5	0,0 - 20,0	s
$\overline{SEc}$	Spot time	1,0	0,1 - 20,0	s
$\overline{SEc}$	Pause time (interval)	1,0	0,1 - 20,0	s
$\overline{rbd}$	Wire burn-back	0	-50 - 50	%
TIG				
$\overline{GPr}$	Gas pre-flow time	0,5	0,0 - 5,0	s
$\overline{iSt}$	Ignition current	20	1 - 200	%
$\overline{tUp}$	Up-slope time	1,0	0,0 - 20,0	s
$\overline{tDn}$	Down-slope time	1,0	0,0 - 20,0	s
$\overline{iEd}$	End current	20	1 - 200	%
$\overline{SEc}$	Gas post-flow time	4,0	0,0 - 20,0	s
MMA				
$\overline{Arc}$	Arcforce correction	0	-10 - 10	
$\overline{iHt}$	Hot start current	120	50 - 200	%
$\overline{tHt}$	Hot start time	0,5	0,1 - 20,0	s
Basic parameters (independent of procedure)				
$\overline{cAL}$	Calibration			
$\overline{End}$	Exit menu			
$\overline{cFG}$	Machine configuration			
$\overline{FUS}$	Dynamic power adjustment	16	16 - 20	A
$\overline{SbA}$	Time-based power-saving mode	20	5 - 60	min.
$\overline{aPt}$	Arcdetection for welding helmets (TIG)	off	off - on	
$\overline{Sru}$	Service menu			
$\overline{uEr}$	Softwareversion of the machine control			
$\overline{-}$	Power-saving mode active			



### 11.3 Searching for a dealer

Sales & service partners  
[www.ewm-group.com/en/specialist-dealers](http://www.ewm-group.com/en/specialist-dealers)



"More than 400 EWM sales partners worldwide"