



EN

Welding machine

Taurus 400 Basic TDG

099-005446-EW501

Observe additional system documents!

22.02.2017

**Register now
and benefit!
Jetzt Registrieren
und Profitieren!**

www.ewm-group.com



General instructions

WARNING



Read the operating instructions!

The operating instructions provide an introduction to the safe use of the products.

- Read and observe the operating instructions for all system components, especially the safety instructions and warning notices!
- Observe the accident prevention regulations and any regional regulations!
- The operating instructions must be kept at the location where the machine is operated.
- Safety and warning labels on the machine indicate any possible risks. Keep these labels clean and legible at all times.
- The machine has been constructed to state-of-the-art standards in line with any applicable regulations and industrial standards. Only trained personnel may operate, service and repair the machine.
- Technical changes due to further development in machine technology may lead to a differing welding behaviour.



In the event of queries on installation, commissioning, operation or special conditions at the installation site, or on usage, please contact your sales partner or our customer service department on +49 2680 181-0.

A list of authorised sales partners can be found at www.ewm-group.com.

Liability relating to the operation of this equipment is restricted solely to the function of the equipment. No other form of liability, regardless of type, shall be accepted. This exclusion of liability shall be deemed accepted by the user on commissioning the equipment.

The manufacturer is unable to monitor whether or not these instructions or the conditions and methods are observed during installation, operation, usage and maintenance of the equipment.

An incorrectly performed installation can result in material damage and injure persons as a result. For this reason, we do not accept any responsibility or liability for losses, damages or costs arising from incorrect installation, improper operation or incorrect usage and maintenance or any actions connected to this in any way.

© EWM AG

Dr. Günter-Henle-Straße 8

56271 Mündersbach

Germany

The copyright to this document remains the property of the manufacturer.

Copying, including extracts, only permitted with written approval.

The content of this document has been prepared and reviewed with all reasonable care. The information provided is subject to change; errors excepted.

1 Contents

| | | |
|----------|--|-----------|
| 1 | Contents | 3 |
| 2 | For your safety | 5 |
| 2.1 | Notes on the use of these operating instructions | 5 |
| 2.1.1 | Explanation of icons | 6 |
| 2.2 | Part of the complete documentation | 7 |
| 2.3 | Safety instructions | 7 |
| 2.4 | Transport and installation | 10 |
| 3 | Intended use | 12 |
| 3.1 | Applications | 12 |
| 3.1.1 | Use and operation solely with the following machines | 12 |
| 3.2 | Documents which also apply | 12 |
| 3.2.1 | Warranty | 12 |
| 3.2.2 | Declaration of Conformity | 12 |
| 3.2.3 | Welding in environments with increased electrical hazards | 12 |
| 3.2.4 | Service documents (spare parts and circuit diagrams) | 12 |
| 3.2.5 | Calibration/Validation | 13 |
| 4 | Machine description – quick overview | 14 |
| 4.1 | Front view | 14 |
| 4.2 | Rear view | 15 |
| 4.3 | Machine control – Operating elements | 16 |
| 5 | Design and function | 17 |
| 5.1 | Transport and installation | 17 |
| 5.1.1 | Ambient conditions | 17 |
| 5.1.1.1 | In operation | 17 |
| 5.1.1.2 | Transport and storage | 17 |
| 5.1.2 | Machine cooling | 17 |
| 5.1.3 | Workpiece lead, general | 18 |
| 5.1.4 | Adjusting the length of the carrying strap | 18 |
| 5.1.5 | Cable strap | 19 |
| 5.1.6 | Cable holder | 19 |
| 5.1.6.1 | Assembly | 20 |
| 5.1.6.2 | Application | 20 |
| 5.1.7 | Protective flap, welding machine control | 21 |
| 5.1.7.1 | Deinstallation/Installation | 21 |
| 5.1.8 | Notes on the installation of welding current leads | 22 |
| 5.1.8.1 | Stray welding currents | 23 |
| 5.1.9 | Mains connection | 23 |
| 5.1.9.1 | Mains configuration | 23 |
| 5.2 | Welding data display | 24 |
| 5.3 | MIG/MAG welding | 25 |
| 5.3.1 | Connecting the intermediate hose package to the power source | 25 |
| 5.3.2 | Welding task selection | 25 |
| 5.3.3 | MIG/MAG functional sequences / operating modes | 27 |
| 5.3.3.1 | Explanation of signs and functions | 27 |
| 5.4 | MMA welding | 29 |
| 5.4.1 | Connecting the electrode holder and workpiece lead | 30 |
| 5.4.2 | Welding task selection | 30 |
| 5.4.2.1 | Arcforce | 31 |
| 5.4.2.2 | Hotstart | 31 |
| 5.4.2.3 | Antistick | 31 |
| 5.4.3 | Arc length restriction (USP) | 31 |
| 5.4.4 | Expert menu (MMA) | 32 |
| 5.5 | Remote control | 32 |
| 5.5.1 | RT1 19POL | 32 |
| 5.5.2 | RTG1 19POL | 32 |
| 5.6 | Power-saving mode (Standby) | 33 |

| | | |
|-----------|---|-----------|
| 5.7 | Machine configuration menu | 33 |
| 5.7.1 | Selecting, changing and saving parameters..... | 33 |
| 6 | Maintenance, care and disposal | 35 |
| 6.1 | General..... | 35 |
| 6.2 | Cleaning | 35 |
| 6.3 | Maintenance work, intervals | 35 |
| 6.3.1 | Daily maintenance tasks..... | 36 |
| 6.3.1.1 | Visual inspection | 36 |
| 6.3.1.2 | Functional test..... | 36 |
| 6.3.2 | Monthly maintenance tasks | 36 |
| 6.3.2.1 | Visual inspection | 36 |
| 6.3.2.2 | Functional test..... | 36 |
| 6.3.3 | Annual test (inspection and testing during operation) | 36 |
| 6.4 | Disposing of equipment..... | 37 |
| 6.4.1 | Manufacturer's declaration to the end user | 37 |
| 6.5 | Meeting the requirements of RoHS..... | 37 |
| 7 | Rectifying faults..... | 38 |
| 7.1 | Checklist for rectifying faults | 38 |
| 7.2 | Error messages (power source)..... | 39 |
| 7.3 | Resetting welding parameters to the factory settings | 40 |
| 8 | Technical data..... | 41 |
| 8.1 | Taurus 400 Basic TDG..... | 41 |
| 9 | Accessories | 42 |
| 9.1 | System components..... | 42 |
| 9.1.1 | Wire feed unit..... | 42 |
| 9.2 | Options..... | 42 |
| 9.3 | Remote controls and accessories..... | 42 |
| 9.4 | General accessories | 42 |
| 10 | Appendix A..... | 43 |
| 10.1 | Parameter overview – setting information..... | 43 |
| 11 | Appendix B..... | 44 |
| 11.1 | Overview of EWM branches..... | 44 |

2 For your safety

2.1 Notes on the use of these operating instructions

DANGER

Working or operating procedures which must be closely observed to prevent imminent serious and even fatal injuries.

- Safety notes include the "DANGER" keyword in the heading with a general warning symbol.
- The hazard is also highlighted using a symbol on the edge of the page.

WARNING

Working or operating procedures which must be closely observed to prevent serious and even fatal injuries.

- Safety notes include the "WARNING" keyword in the heading with a general warning symbol.
- The hazard is also highlighted using a symbol in the page margin.

CAUTION

Working or operating procedures which must be closely observed to prevent possible minor personal injury.

- The safety information includes the "CAUTION" keyword in its heading with a general warning symbol.
- The risk is explained using a symbol on the edge of the page.



Special technical points which users must observe.

Instructions and lists detailing step-by-step actions for given situations can be recognised via bullet points, e.g.:

- Insert the welding current lead socket into the relevant socket and lock.

2.1.1 Explanation of icons

| Symbol | Description | Symbol | Description |
|--------|---|--------|---------------------------------|
| | Indicates technical aspects which the user must observe. | | Activate and release/tap/tip |
| | Switch off machine | | Release |
| | Switch on machine | | Press and keep pressed |
| | | | Switch |
| | Wrong | | Turn |
| | Correct | | Numerical value – adjustable |
| | Menu entry | | Signal light lights up in green |
| | Navigating the menu | | Signal light flashes green |
| | Exit menu | | Signal light lights up in red |
| | Time representation (e.g.: wait 4 s/activate) | | Signal light flashes red |
| | Interruption in the menu display (other setting options possible) | | |
| | Tool not required/do not use | | |
| | Tool required/use | | |

2.2 Part of the complete documentation

These operating instructions are part of the complete documentation and valid only in combination with all other parts of these instructions! Read and observe the operating instructions for all system components, especially the safety instructions!

The illustration shows a general example of a welding system.

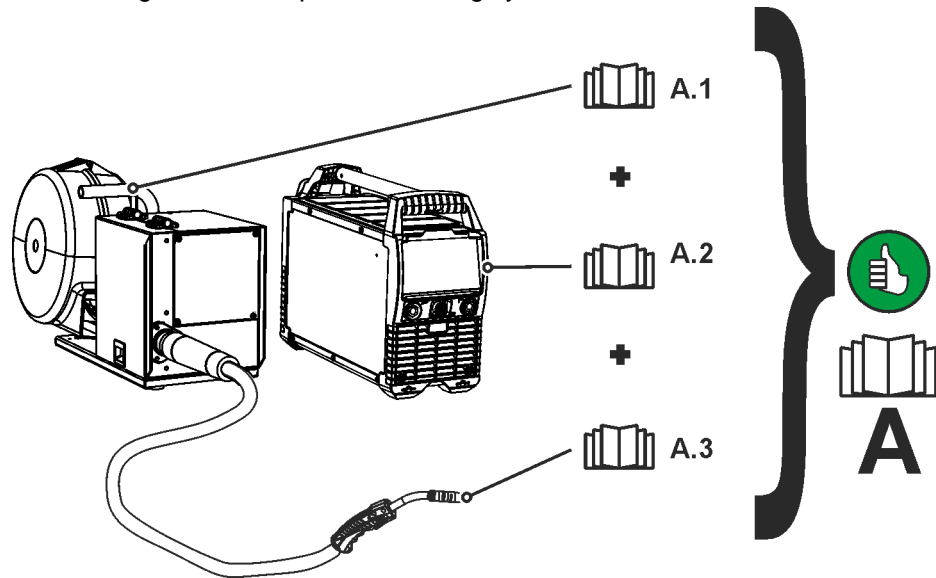

Figure 2-1

| Item | Documentation |
|------|------------------------|
| A.1 | Wire feeder |
| A.2 | Power source |
| A.3 | Welding torch |
| A | Complete documentation |

2.3 Safety instructions

WARNING



Risk of accidents due to non-compliance with the safety instructions!
Non-compliance with the safety instructions can be fatal!

- Carefully read the safety instructions in this manual!
- Observe the accident prevention regulations and any regional regulations!
- Inform persons in the working area that they must comply with the regulations!



Risk of injury from electrical voltage!

Voltages can cause potentially fatal electric shocks and burns on contact. Even low voltages can cause a shock and lead to accidents.

- Never touch live components such as welding current sockets or stick, tungsten or wire electrodes!
- Always place torches and electrode holders on an insulated surface!
- Wear the full personal protective equipment (depending on the application)!
- The machine may only be opened by qualified personnel!

WARNING



Hazard when interconnecting multiple power sources!

If a number of power sources are to be connected in parallel or in series, only a technical specialist may interconnect the sources as per standard *IEC 60974-9:2010: Installation and use* and German Accident Prevention Regulation *BVG D1 (formerly VBG 15)* or country-specific regulations.

Before commencing arc welding, a test must verify that the equipment cannot exceed the maximum permitted open circuit voltage.

- Only qualified personnel may connect the machine.
- When taking individual power sources out of operation, all mains and welding current leads must be safely disconnected from the welding system as a whole. (Hazard due to reverse polarity voltage!)
- Do not interconnect welding machines with pole reversing switch (PWS series) or machines for AC welding since a minor error in operation can cause the welding voltages to be combined, which is not permitted.



Risk of injury due to improper clothing!

During arc welding, radiation, heat and voltage are sources of risk that cannot be avoided. The user has to be equipped with the complete personal protective equipment at all times. The protective equipment has to include:

- Respiratory protection against hazardous substances and mixtures (fumes and vapours); otherwise implement suitable measures such as extraction facilities.
- Welding helmet with proper protection against ionizing radiation (IR and UV radiation) and heat.
- Dry welding clothing (shoes, gloves and body protection) to protect against warm environments with conditions comparable to ambient temperatures of 100 °C or higher and arcing and work on live components.
- Hearing protection against harming noise.



Risk of injury due to radiation or heat!

Arc radiation results in injury to skin and eyes.

Contact with hot workpieces and sparks results in burns.

- Use welding shield or welding helmet with the appropriate safety level (depending on the application)!
- Wear dry protective clothing (e.g. welding shield, gloves, etc.) according to the relevant regulations in the country in question!
- Protect persons not involved in the work against arc beams and the risk of glare using safety curtains!



Explosion risk!

Apparently harmless substances in closed containers may generate excessive pressure when heated.

- Move containers with inflammable or explosive liquids away from the working area!
- Never heat explosive liquids, dusts or gases by welding or cutting!



Fire hazard!

Due to the high temperatures, sparks, glowing parts and hot slag that occur during welding, there is a risk of flames.

- Be watchful of potential sources of fire in the working area!
- Do not carry any easily inflammable objects, e.g. matches or lighters.
- Ensure suitable fire extinguishers are available in the working area!
- Thoroughly remove any residue of flammable materials from the workpiece prior to starting to weld.
- Only further process workpieces after they have cooled down. Do not allow them to contact any flammable materials!

⚠ CAUTION**Smoke and gases!**

Smoke and gases can lead to breathing difficulties and poisoning. In addition, solvent vapour (chlorinated hydrocarbon) may be converted into poisonous phosgene due to the ultraviolet radiation of the arc!

- Ensure that there is sufficient fresh air!
- Keep solvent vapour away from the arc beam field!
- Wear suitable breathing apparatus if appropriate!

**Noise exposure!**

Noise exceeding 70 dBA can cause permanent hearing damage!

- Wear suitable ear protection!
- Persons located within the working area must wear suitable ear protection!

**Obligations of the operator!**

The respective national directives and laws must be complied with when operating the machine!

- *Implementation of national legislation relating to framework directive 89/391/EEC on the introduction of measures to encourage improvements in the safety and health of workers at work and associated individual guidelines.*
- *In particular, directive 89/655/EEC concerning the minimum safety and health requirements for the use of work equipment by workers at work.*
- *The regulations applicable to occupational safety and accident prevention in the country concerned.*
- *Setting up and operating the machine as per IEC 60974.-9.*
- *Brief the user on safety-conscious work practices on a regular basis.*
- *Regularly inspect the machine as per IEC 60974.-4.*

**The manufacturer's warranty becomes void if non-genuine parts are used!**

- *Only use system components and options (power sources, welding torches, electrode holders, remote controls, spare parts and replacement parts, etc.) from our range of products!*
- *Only insert and lock accessory components into the relevant connection socket when the machine is switched off.*

**Requirements for connection to the public mains network**

High-performance machines can influence the mains quality by taking current from the mains network. For some types of machines, connection restrictions or requirements relating to the maximum possible line impedance or the necessary minimum supply capacity at the interface with the public network (Point of Common Coupling, PCC) can therefore apply. In this respect, attention is also drawn to the machines' technical data. In this case, it is the responsibility of the operator, where necessary in consultation with the mains network operator, to ensure that the machine can be connected.

⚠ CAUTION**Electromagnetic fields!**

The power source may cause electrical or electromagnetic fields to be produced which could affect the correct functioning of electronic equipment such as IT or CNC devices, telecommunication lines, power cables, signal lines and pacemakers.



- Observe the maintenance instructions > see 6.3 chapter!
- Unwind welding leads completely!
- Shield devices or equipment sensitive to radiation accordingly!
- The correct functioning of pacemakers may be affected (obtain advice from a doctor if necessary).

⚠ CAUTION



According to IEC 60974-10, welding machines are divided into two classes of electromagnetic compatibility (the EMC class can be found in the Technical data) > see 8 chapter:



Class A machines are not intended for use in residential areas where the power supply comes from the low-voltage public mains network. When ensuring the electromagnetic compatibility of class A machines, difficulties can arise in these areas due to interference not only in the supply lines but also in the form of radiated interference.



Class B machines fulfil the EMC requirements in industrial as well as residential areas, including residential areas connected to the low-voltage public mains network.

Setting up and operating

When operating arc welding systems, in some cases, electro-magnetic interference can occur although all of the welding machines comply with the emission limits specified in the standard. The user is responsible for any interference caused by welding.

In order to **evaluate** any possible problems with electromagnetic compatibility in the surrounding area, the user must consider the following: (see also EN 60974-10 Appendix A)

- Mains, control, signal and telecommunication lines
- Radios and televisions
- Computers and other control systems
- Safety equipment
- The health of neighbouring persons, especially if they have a pacemaker or wear a hearing aid
- Calibration and measuring equipment
- The immunity to interference of other equipment in the surrounding area
- The time of day at which the welding work must be carried out

Recommendations for **reducing interference emission**

- Mains connection, e.g. additional mains filter or shielding with a metal tube
- Maintenance of the arc welding system
- Welding leads should be as short as possible and run closely together along the ground
- Potential equalization
- Earthing of the workpiece. In cases where it is not possible to earth the workpiece directly, it should be connected by means of suitable capacitors.
- Shielding from other equipment in the surrounding area or the entire welding system

2.4 Transport and installation

⚠ WARNING



Risk of injury due to improper handling of shielding gas cylinders!
Improper handling and insufficient securing of shielding gas cylinders can cause serious injuries!

- Observe the instructions from the gas manufacturer and any relevant regulations concerning the use of compressed air!
- Do not attach any element to the shielding gas cylinder valve!
- Prevent the shielding gas cylinder from heating up.

⚠ CAUTION



Risk of accidents due to supply lines!
During transport, attached supply lines (mains leads, control cables, etc.) can cause risks, e.g. by causing connected machines to tip over and injure persons!

- Disconnect all supply lines before transport!





Risk of tipping!

There is a risk of the machine tipping over and injuring persons or being damaged itself during movement and set up. Tilt resistance is guaranteed up to an angle of 10° (according to IEC 60974-1).

- Set up and transport the machine on level, solid ground.
- Secure add-on parts using suitable equipment.

-  **The units are designed for operation in an upright position!**
Operation in non-permissible positions can cause equipment damage.
 - **Only transport and operate in an upright position!**

-  **Accessory components and the power source itself can be damaged by incorrect connection!**
 - **Only insert and lock accessory components into the relevant connection socket when the machine is switched off.**
 - **Comprehensive descriptions can be found in the operating instructions for the relevant accessory components.**
 - **Accessory components are detected automatically after the power source is switched on.**

-  **Protective dust caps protect the connection sockets and therefore the machine against dirt and damage.**
 - **The protective dust cap must be fitted if there is no accessory component being operated on that connection.**
 - **The cap must be replaced if faulty or if lost!**

3 Intended use

WARNING



Hazards due to improper usage!

The machine has been constructed to the state of the art and any regulations and standards applicable for use in industry and trade. It may only be used for the welding procedures indicated at the rating plate. Hazards may arise for persons, animals and material objects if the equipment is not used correctly. No liability is accepted for any damages arising from improper usage!

- The equipment must only be used in line with its designated purpose and by trained or expert personnel!
- Do not improperly modify or convert the equipment!

3.1 Applications

Arc welding machine for gas-shielded metal-arc welding and MMA welding as secondary process. It may be possible to expand the range of functions by using accessories (see the documentation in the relevant chapter).

3.1.1 Use and operation solely with the following machines



A suitable wire feed unit (system component) is required in order to operate the welding machine!

- Taurus drive 4L Basic

3.2 Documents which also apply

3.2.1 Warranty



For more information refer to the "Warranty registration" brochure supplied and our information regarding warranty, maintenance and testing at www.ewm-group.com!

3.2.2 Declaration of Conformity



The labelled machine complies with the following EC directives in terms of its design and construction:

- Low Voltage Directive (LVD)
- Electromagnetic Compatibility Directive (EMC)
- Restriction of Hazardous Substance (RoHS)

In case of unauthorised changes, improper repairs, non-compliance with specified deadlines for "Arc Welding Equipment – Inspection and Testing during Operation", and/or prohibited modifications which have not been explicitly authorised by EWM, this declaration shall be voided. An original document of the specific declaration of conformity is included with every product.

3.2.3 Welding in environments with increased electrical hazards



In compliance with IEC / DIN EN 60974, VDE 0544 the machines can be used in environments with an increased electrical hazard.

3.2.4 Service documents (spare parts and circuit diagrams)

WARNING



Do not carry out any unauthorised repairs or modifications!

To avoid injury and equipment damage, the unit must only be repaired or modified by specialist, skilled persons!

The warranty becomes null and void in the event of unauthorised interference.

- Appoint only skilled persons for repair work (trained service personnel)!

Original copies of the circuit diagrams are enclosed with the unit.

Spare parts can be obtained from the relevant authorised dealer.

3.2.5 Calibration/Validation

We hereby confirm that this machine has been tested using calibrated measuring equipment, as stipulated in IEC/EN 60974, ISO/EN 17662, EN 50504, and complies with the admissible tolerances.
Recommended calibration interval: 12 months

4 Machine description – quick overview

4.1 Front view

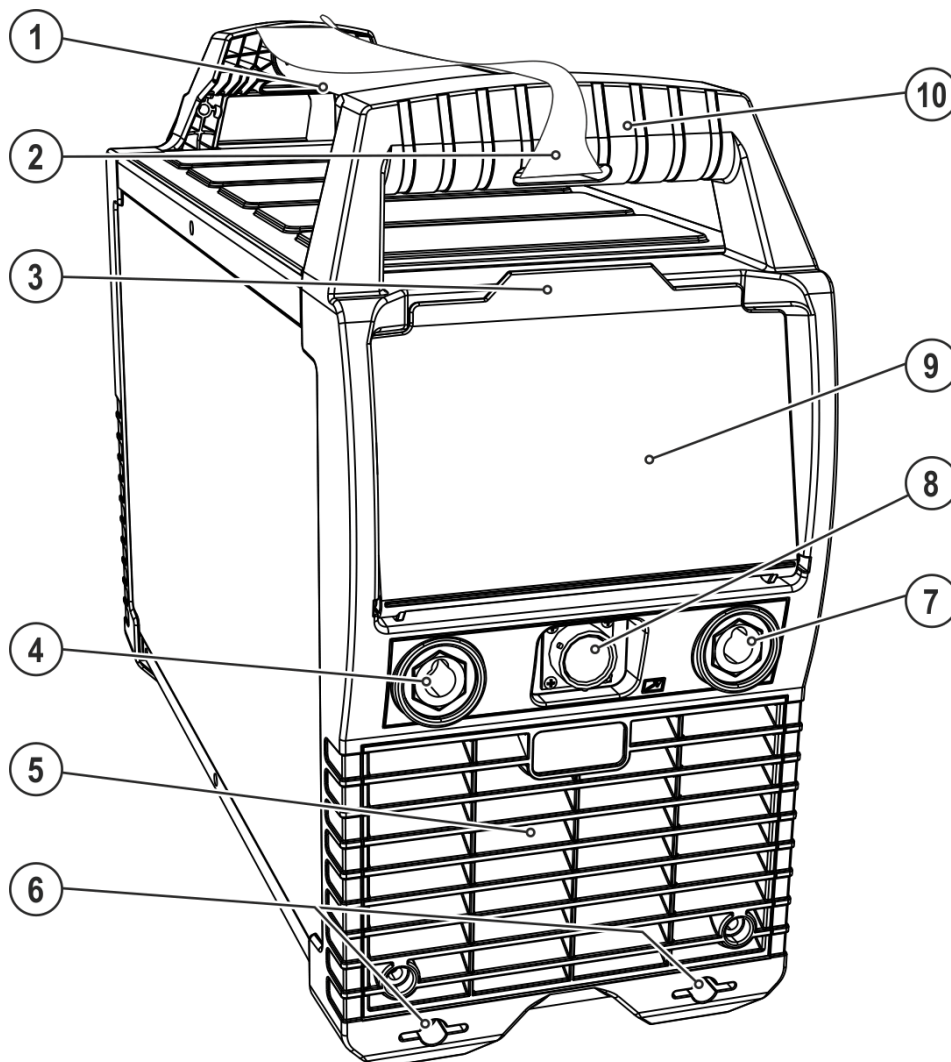

Figure 4-1

| Item | Symbol | Description |
|------|--------|--|
| 1 | | Transport bar |
| 2 | | Carrying strap > see 5.1.4 chapter |
| 3 | | Protective cap |
| 4 | | Connection socket, “+” welding current How to connect the accessories depends on the welding procedure. Please observe the connection description for the corresponding welding procedure > see 5 chapter. |
| 5 | | Cooling air inlet Dirt filter can be retrofitted |
| 6 | | Machine feet |
| 7 | | Connection socket, “-” welding current How to connect the accessories depends on the welding procedure. Please observe the connection description for the corresponding welding procedure > see 5 chapter. |
| 8 | | 19-pole connection socket Control cable for remote control and/or wire feeder |
| 9 | | Protective cap, welding machine control > see 4.3 chapter |
| 10 | | Carrying handle |

4.2 Rear view

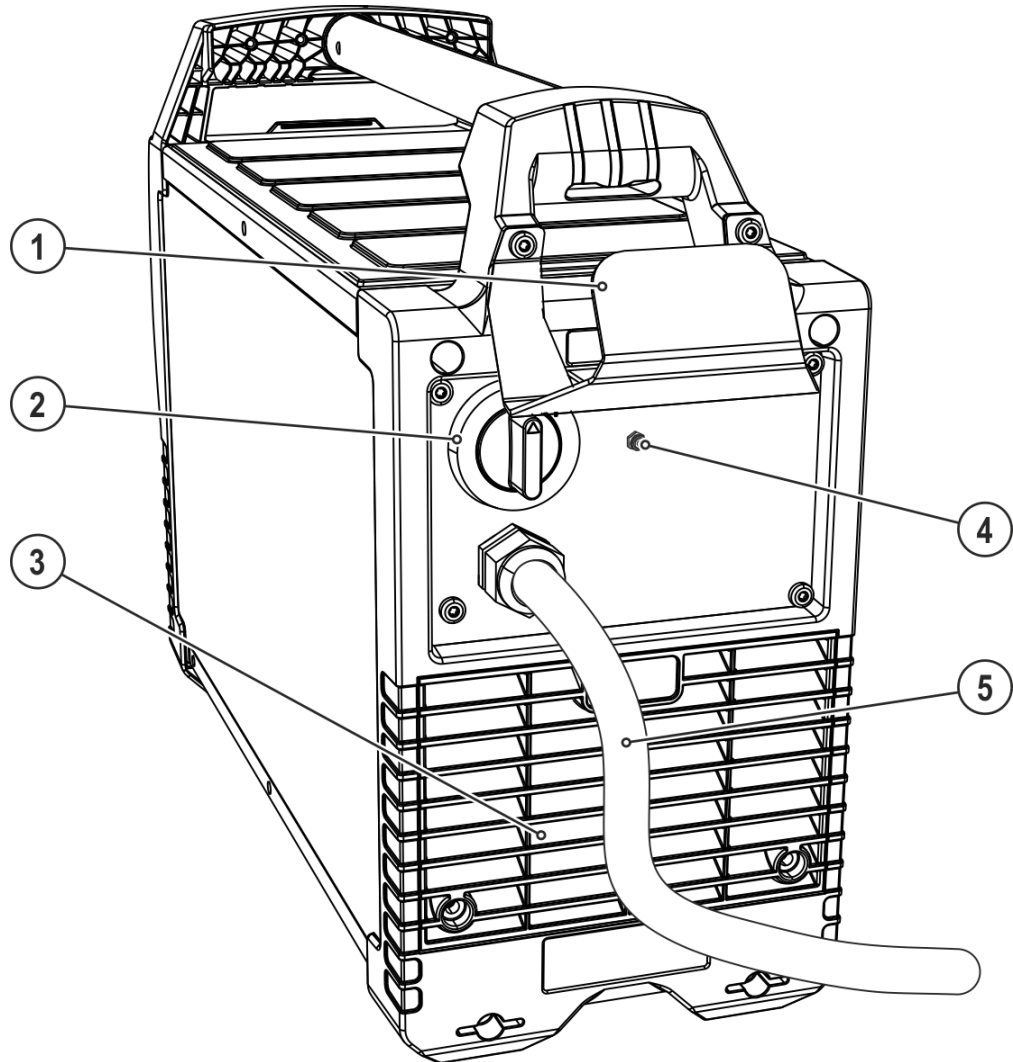

Figure 4-2

| Item | Symbol | Description |
|------|--------|---|
| 1 | | Cable holder |
| 2 | | Main switch, machine on/off |
| 3 | | Cooling air outlet |
| 4 | | Key button, automatic cutout Wire feed motor supply voltage fuse press to reset a triggered fuse |
| 5 | | Mains connection cable > see 5.1.9 chapter |

4.3 Machine control – Operating elements

The setting ranges for the parameter values are summarised in the Parameter overview section > see 10.1 chapter.

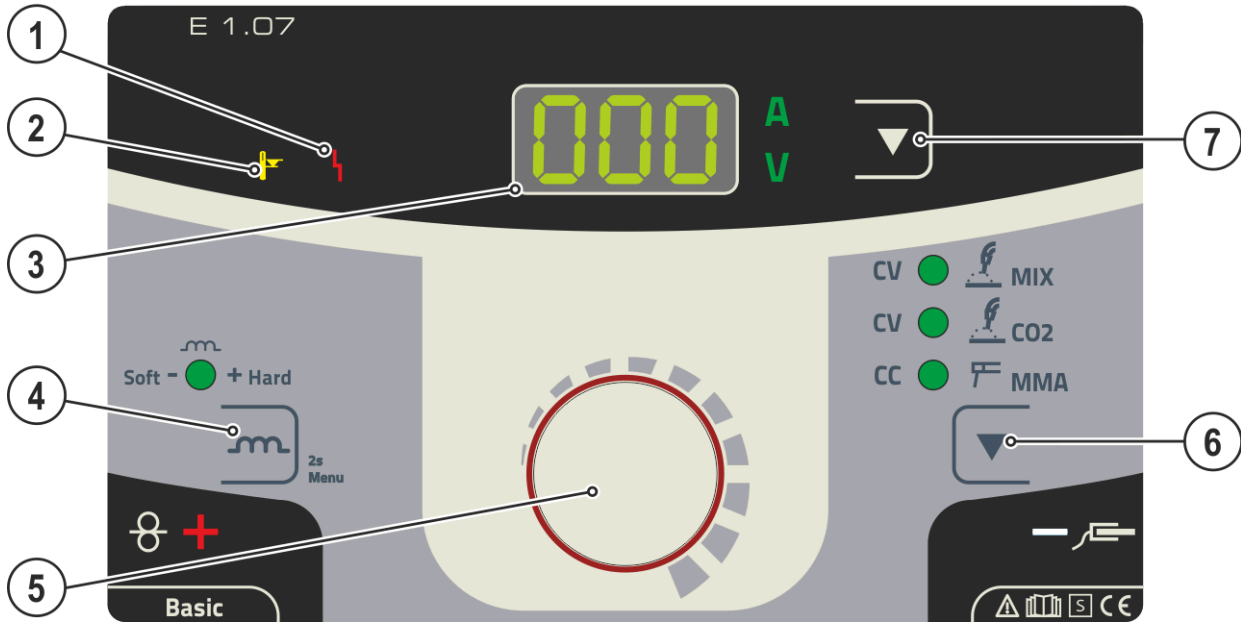

Figure 4-3

| Item | Symbol | Description |
|------|--------|--|
| 1 | | Collective interference signal light For error messages, > see 7 chapter |
| 2 | | Excess temperature signal light In case of excess temperature, temperature monitors de-activate the power unit, and the excess temperature control lamp comes on. Once the machine has cooled down, welding can continue without any further measures. |
| 3 | | Welding data display (3-digit) Displays the welding parameters and the corresponding values > see 5.2 chapter |
| 4 | | Choke effect/Arcforce push-button MIG/MAG Choke effect (arc dynamics) > see 5.3.2 chapter MMA ---- Arcforce > see 5.4.2 chapter |
| 5 | | Welding parameter setting rotary transducer Setting of welding current and other welding parameter and their values |
| 6 | | Welding procedure push-button MIX - MIG/MAG welding with default constant voltage characteristics "CV constant voltage" for welding with argon and MIX gases. CO2 - MAG welding with default constant voltage characteristics "CV constant voltage" for welding with 100% CO2. MMA MMA welding with constant current characteristics "CC constant current". |
| 7 | | Display/Power-saving mode switching push-button A ----- Welding current display V ----- Welding voltage display STBY --- Press for 2 s to put machine into power-saving mode. To reactivate, activate one of the operating elements. |

5 Design and function

⚠ WARNING



Risk of injury from electric shock!

Contact with live parts, e.g. welding current sockets, is potentially fatal!

- Follow safety instructions on the opening pages of the operating instructions.
- Commissioning may only be carried out by persons who have the relevant expertise of working with arc welding machines!
- Connection and welding leads (e.g. electrode holder, welding torch, workpiece lead, interfaces) may only be connected when the machine is switched off!

5.1 Transport and installation

⚠ WARNING



Risk of accident due to improper transport of machines that must not be lifted!

Do not lift or suspend the machine! The machine can drop and cause injuries! The handles, straps or brackets are suitable for transport by hand only!

- The machine must not be suspended or lifted using a crane.

👉 **Read and observe the documentation to all system and accessory components!**

5.1.1 Ambient conditions

👉 **The machine may only be placed and operated on a suitable, load-bearing and even surface (according to IP 34s in case of outside operation as well)!**

- **Ensure the machine is operated on an even, anti-slip floor and provide sufficient lighting of the work area.**
- **Safe operation of the machine must be guaranteed at all times!**

👉 **Unusually high quantities of dust, acid, corrosive gases or substances may damage the equipment.**

- **Avoid high volumes of smoke, vapour, oil vapour and grinding dust!**
- **Avoid ambient air containing salt (sea air)!**

5.1.1.1 In operation

Temperature range of the ambient air:

- -25 °C to +40 °C

Relative air humidity:

- Up to 50% at 40 °C
- Up to 90% at 20 °C

5.1.1.2 Transport and storage

Storage in an enclosed space, temperature range of the ambient air:

- -30 °C to +70 °C

Relative air humidity

- Up to 90% at 20 °C

5.1.2 Machine cooling

👉 **Insufficient ventilation results in a reduction in performance and equipment damage.**

- **Observe the ambient conditions!**
- **Keep the cooling air inlet and outlet clear!**
- **Observe the minimum distance of 0.5 m from obstacles!**

5.1.3 Workpiece lead, general

⚠ CAUTION



Risk of burning due to incorrect welding current connection!

If the welding current plugs (machine connections) are not locked or if the workpiece connection is contaminated (paint, corrosion), these connections and leads can heat up and cause burns when touched!

- Check welding current connections on a daily basis and lock by turning to the right when necessary.
- Clean workpiece connection thoroughly and secure properly. Do not use structural parts of the workpiece as welding current return lead!

5.1.4 Adjusting the length of the carrying strap



To demonstrate adjustment, lengthening the strap is shown in the figure. To shorten, the strap's loops must be inched in the opposite direction.

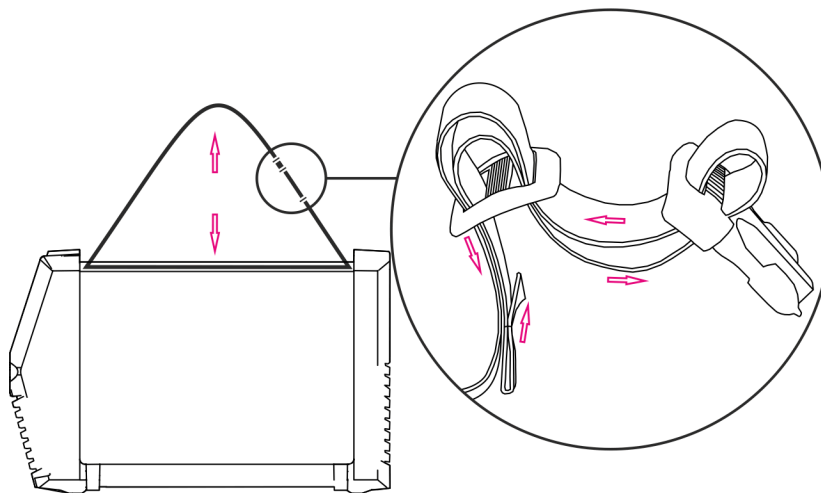

Figure 5-1

5.1.5 Cable strap

In the delivery state, the machine has a cable strap for easy and orderly transport of earth lead, welding torch, electrode holder etc. The following figure shows the fastened strap and how the components can be secured.

The machine itself may not be transported with this cable strap!

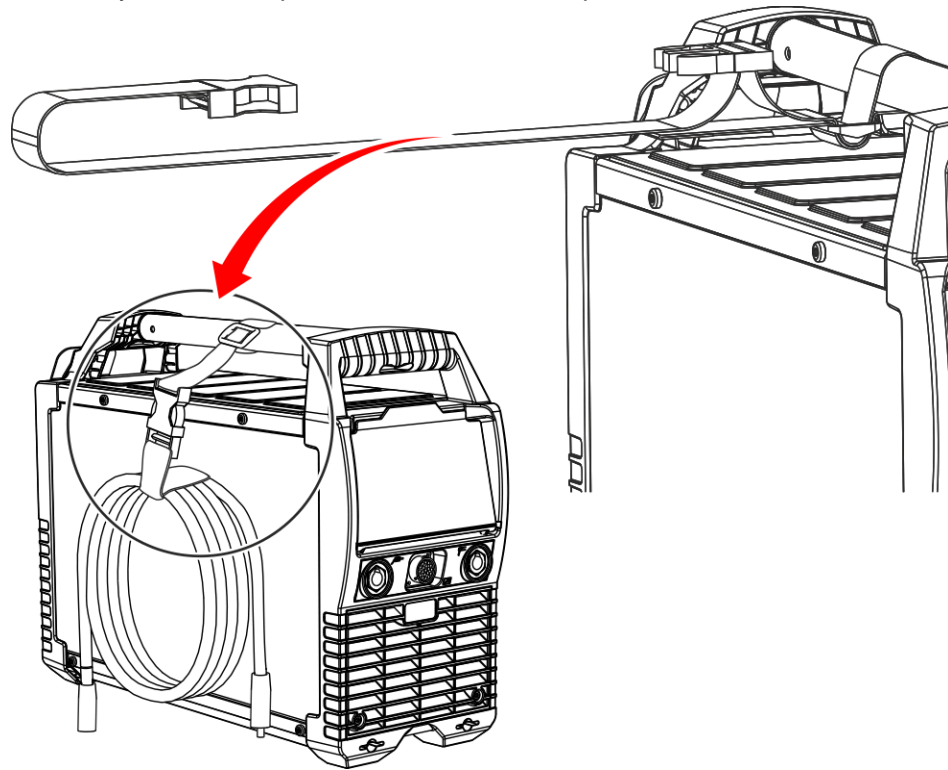

Figure 5-2

5.1.6 Cable holder

The machine is supplied with a cable holder with mounting material. This cable holder can be used to coil and conveniently transport the mains cable. Install the cable holder as shown in the figure.

5.1.6.1 Assembly

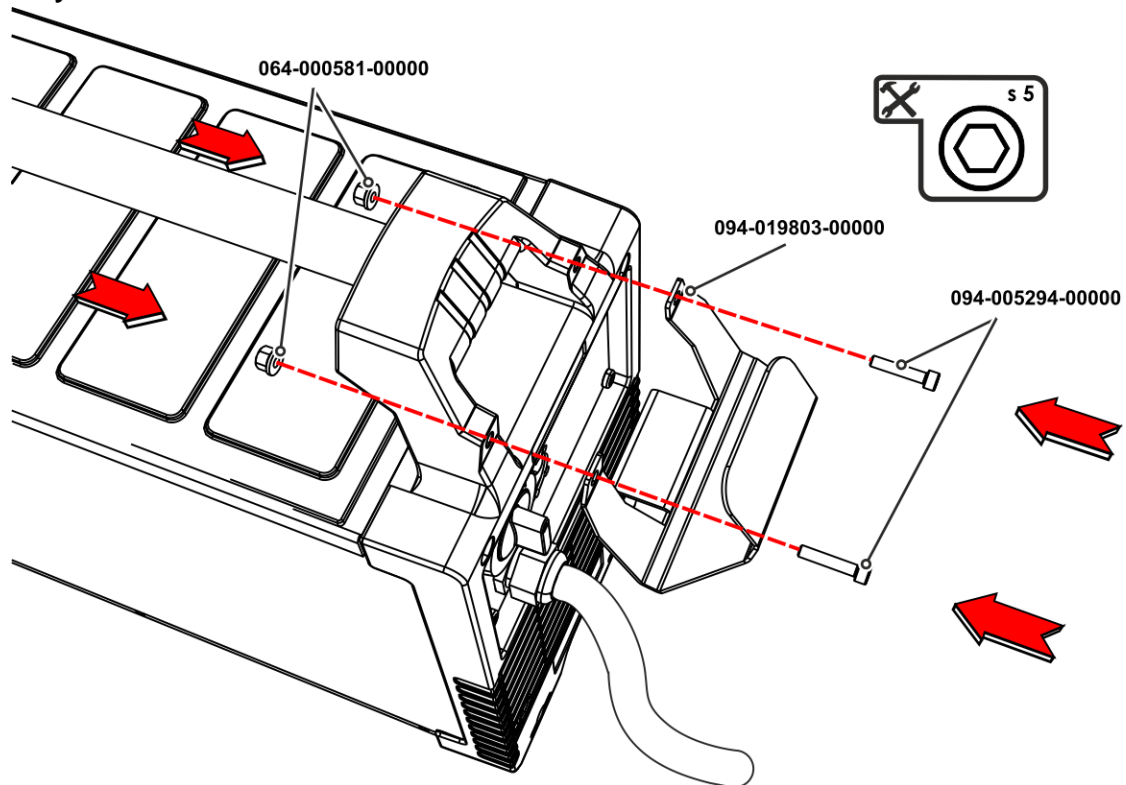

Figure 5-3

5.1.6.2 Application

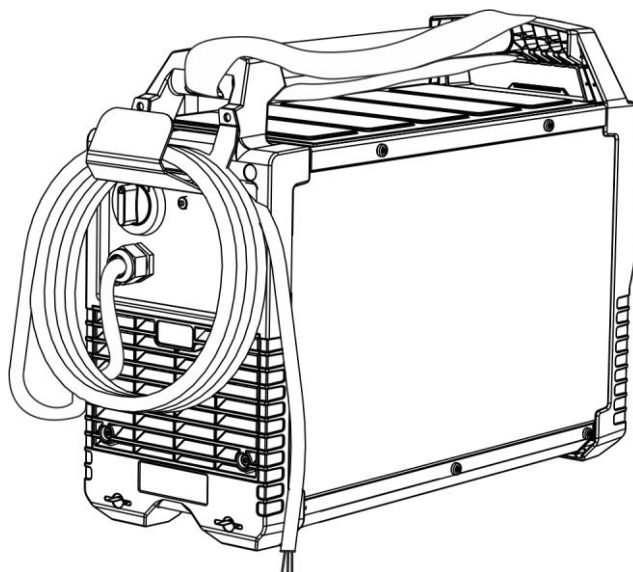

Figure 5-4

5.1.7 Protective flap, welding machine control

5.1.7.1 Deinstallation/Installation

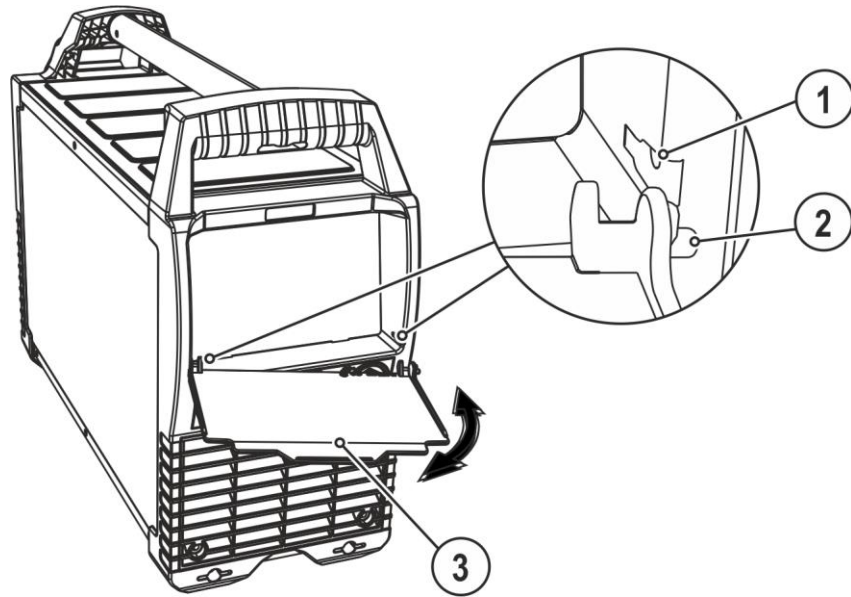

Figure 5-5

| Item | Symbol | Description |
|------|--------|----------------------------------|
| 1 | | Seating hole for mounting nipple |
| 2 | | Mounting nipple, protective cap |
| 3 | | Protective cap |

- Remove the protective cap by gently pressing from the side while simultaneously pulling. To attach, insert and snap into place.

5.1.8 Notes on the installation of welding current leads



Incorrectly installed welding current leads can cause faults in the arc (flickering).

Lay the workpiece lead and hose package of power sources without HF igniter (MIG/MAG) for as long and as close as possible in parallel.

Lay the workpiece lead and hose package of power sources with HF igniter (TIG) for as long as possible in parallel with a distance of 20 cm to avoid HF sparkover.

Always keep a distance of at least 20 cm to leads of other power sources to avoid interferences

Always keep leads as short as possible! For optimum welding results max. 30 m (welding lead + intermediate hose package + torch lead).

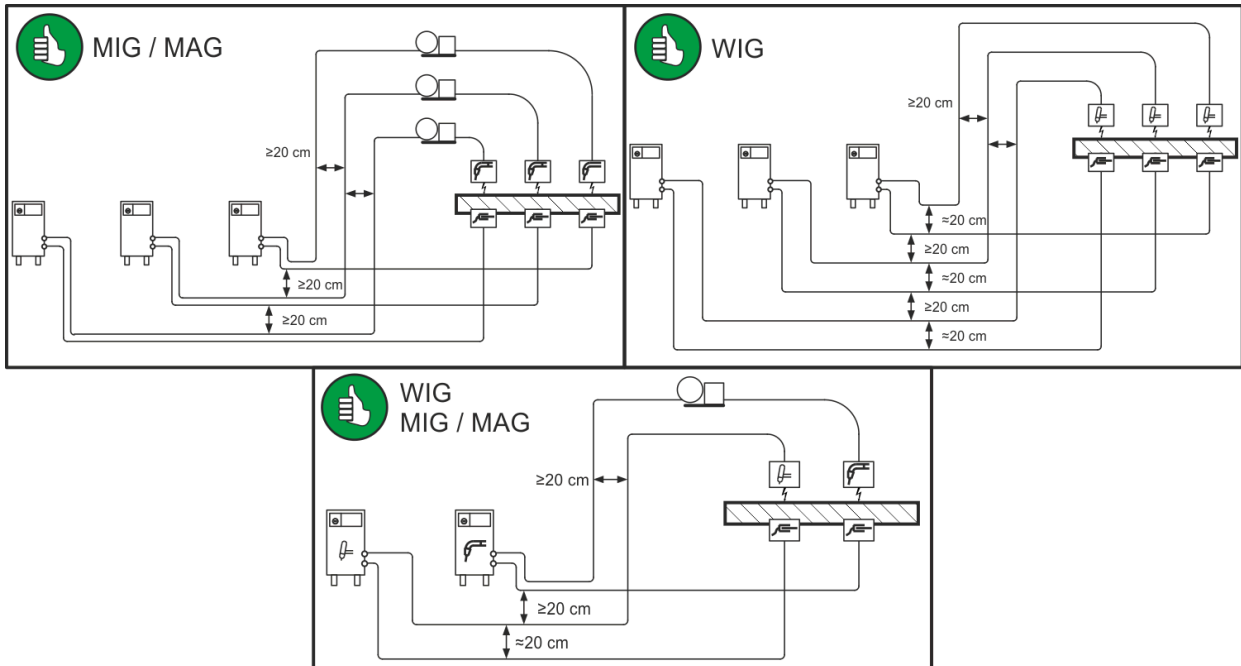

Figure 5-6



Use an individual welding lead to the workpiece for each welding machine!

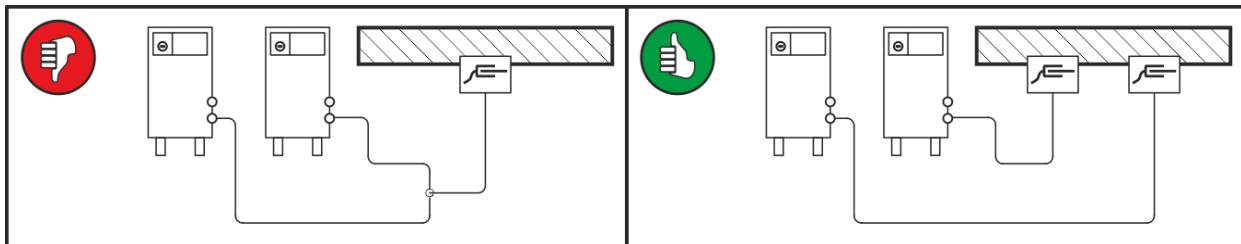

Figure 5-7



Fully unroll welding current leads, torch hose packages and intermediate hose packages. Avoid loops!



Always keep leads as short as possible!



Lay any excess cable lengths in meanders.

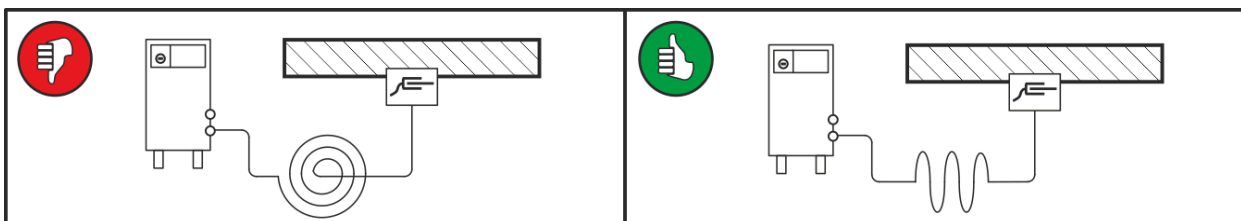

Figure 5-8

5.1.8.1 Stray welding currents

⚠ WARNING**Risk of injury due to stray welding currents!**

Stray welding currents can destroy protective earth conductors, damage machines and electronic devices and cause overheating of components, leading to fire.

- Check that all welding current connections are firmly secured and electrical connections are in perfect condition.
- Set up, attach or suspend all conductive power source components such as casing, transport vehicles and crane frames so they are insulated.
- Do not place any other electronic devices such as drills or angle grinders on the power source, transport vehicle or crane frames unless they are insulated.
- Always put welding torches and electrode holders on an insulated surface when they are not in use.

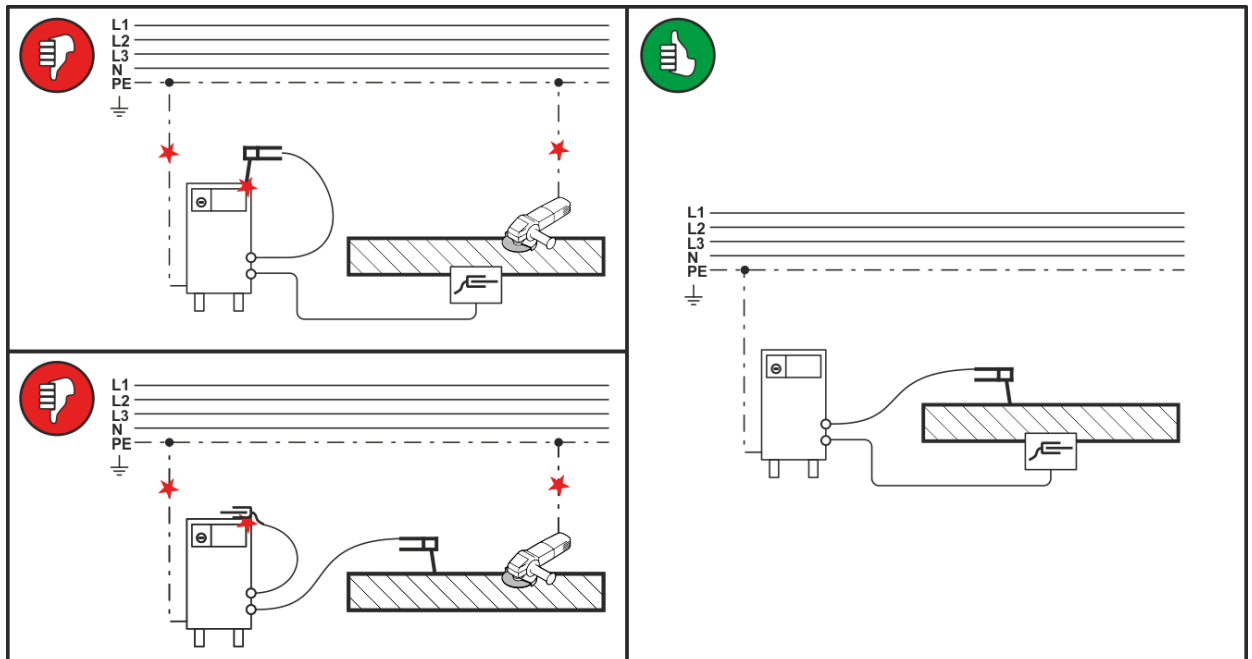

Figure 5-9

5.1.9 Mains connection

⚠ DANGER**Hazards caused by improper mains connection!**

An improper mains connection can cause injuries or damage property!

- Only operate machine using a socket that has correctly fitted protective earth.
- The mains voltage indicated on the rating plate must match the supply voltage.
- If a new mains plug must be fitted, only an electrician may do so as per the relevant national legislation or regulations.
- Mains plug, socket and lead must be checked by an electrician on a regular basis.
- When operating the generator, always ensure it is earthed as stipulated in the operating instructions. The network created must be suitable for operating machines according to protection class I.

5.1.9.1 Mains configuration



The machine may be connected to:

- **a three-phase system with four conductors and an earthed neutral conductor**
- **a three-phase system with three conductors of which any one can be earthed, e.g. the outer conductor**

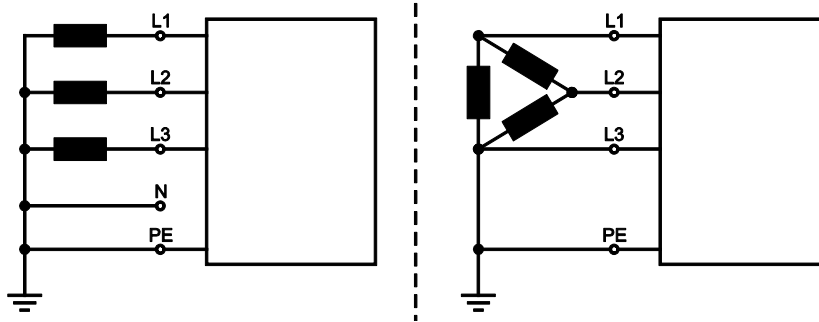

Figure 5-10

Legend

| Item | Designation | Colour code |
|------|----------------------|--------------|
| L1 | Outer conductor 1 | brown |
| L2 | Outer conductor 2 | black |
| L3 | Outer conductor 3 | grey |
| N | Neutral conductor | blue |
| PE | Protective conductor | green-yellow |

- Insert mains plug of the switched-off machine into the appropriate socket.

5.2 Welding data display

All relevant welding parameters with their values are shown depending on the welding procedure selected and the associated functions. Machine parameters and error codes are shown as well in a unique manner. The meaning of the parameters and values shown is explained in the relevant chapter for the function.

Next to the display is the Display/Power-saving mode switching push-button. Each time the push-button is pressed the display switches between the desired parameters.

Depending on the process, the parameters are shown as nominal values (before welding), actual values (during welding) or hold values (after welding):

MIG/MAG welding with constant voltage (CV):

| | Nominal values | Actual values | Hold values (5 s) |
|------------------------|-------------------------------------|-------------------------------------|-------------------------------------|
| Welding current | <input checked="" type="checkbox"/> | <input checked="" type="checkbox"/> | <input checked="" type="checkbox"/> |
| Welding voltage | <input checked="" type="checkbox"/> | <input checked="" type="checkbox"/> | <input checked="" type="checkbox"/> |

By turning the rotary transducer for the welding parameter settings the display automatically switches to the welding voltage display.

MMA welding with constant current (CC):

| | Nominal values | Actual values | Hold values (5 s) |
|-----------------------------|-------------------------------------|---|---|
| Welding current | <input checked="" type="checkbox"/> | <input type="checkbox"/> / <input checked="" type="checkbox"/> ^[1] | <input type="checkbox"/> / <input checked="" type="checkbox"/> ^[1] |
| Welding voltage | <input type="checkbox"/> | <input checked="" type="checkbox"/> | <input checked="" type="checkbox"/> |
| Open circuit voltage | <input checked="" type="checkbox"/> | <input type="checkbox"/> | <input type="checkbox"/> |

By turning the rotary transducer for the welding parameter settings the display automatically switches to the welding current display.

^[1] optional setting > see 5.7 chapter

5.3 MIG/MAG welding

5.3.1 Connecting the intermediate hose package to the power source

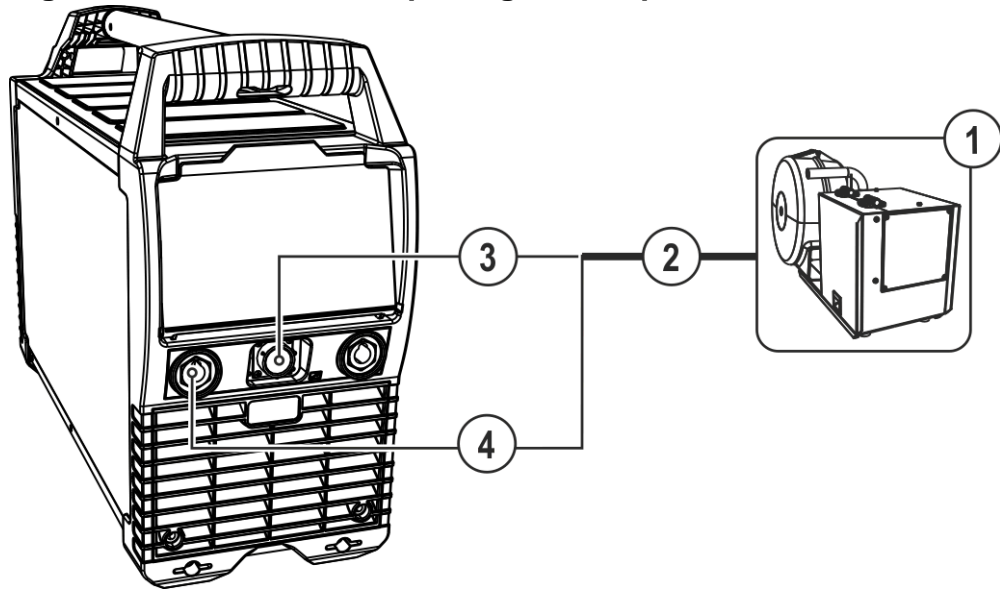



Figure 5-11

| Item | Symbol | Description |
|------|---|--|
| 1 | | Wire feed unit |
| 2 | | Intermediate hose package |
| 3 |  | 19-pole connection socket (analogue) Wire feed unit control lead connection |
| 4 |  | Connection socket, welding current "+" Welding current connection on wire feed unit |

- Insert the plug on the welding current lead into the welding current connection socket "+" and lock.
- Insert cable plug on the control lead into the 19-pole connection socket and secure with crown nut (the plug can only be inserted into the connection socket in one position).



Some wire electrodes (e.g. self-shielding cored wire) are welded using negative polarity. In this case, the welding current lead should be connected to the "-" welding current socket, and the workpiece lead should be connected to the "+" welding current socket. Observe the information from the electrode manufacturer!

5.3.2 Welding task selection



Selection of a welding task involves the interaction of the controls on the welding machine and the wire feed unit. After the basic settings are made on the welding machine, the operating point and other parameters can be set on the wire feed unit.

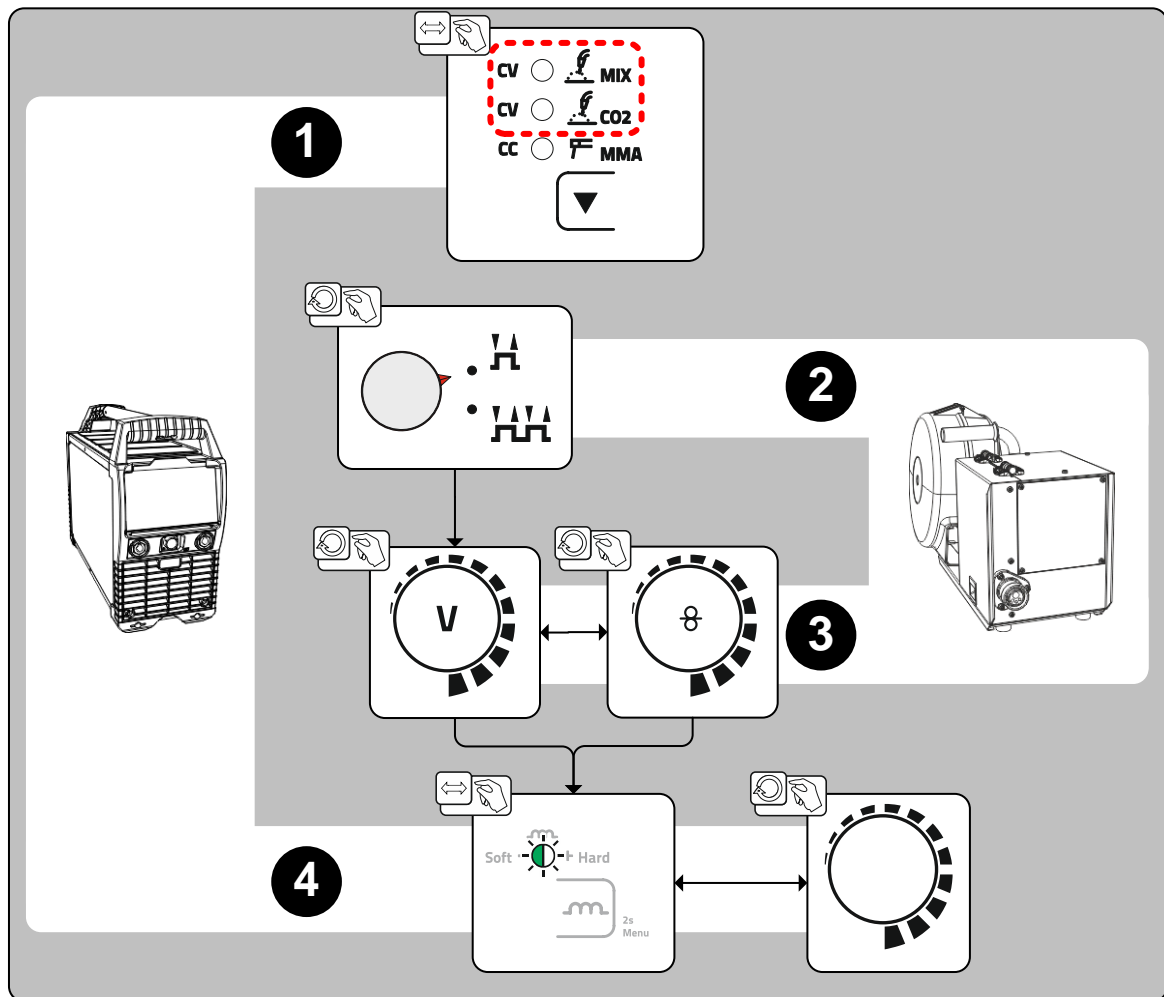











Figure 5-12

 **If you cannot adjust the welding voltage, configuration parameter $\overline{L_{VF}}$ has to be set to \overline{on} > see 5.7 chapter.**

5.3.3 MIG/MAG functional sequences / operating modes

5.3.3.1 Explanation of signs and functions

| Symbol | Meaning |
|--|---|
|  | Press torch trigger |
|  | Release torch trigger |
|  | Tap torch trigger (press briefly and release) |
|  | Shielding gas flowing |
| I | Welding output |
|  | Wire electrode is being conveyed |
|  | Wire creep |
|  | Wire burn-back |
|  | Gas pre-flows |
|  | Gas post-flows |
| H | Non-latched |
| HH | Latched |
| t | Time |
| PSTART | Ignition program |
| PA | Main program |
| PEND | End program |

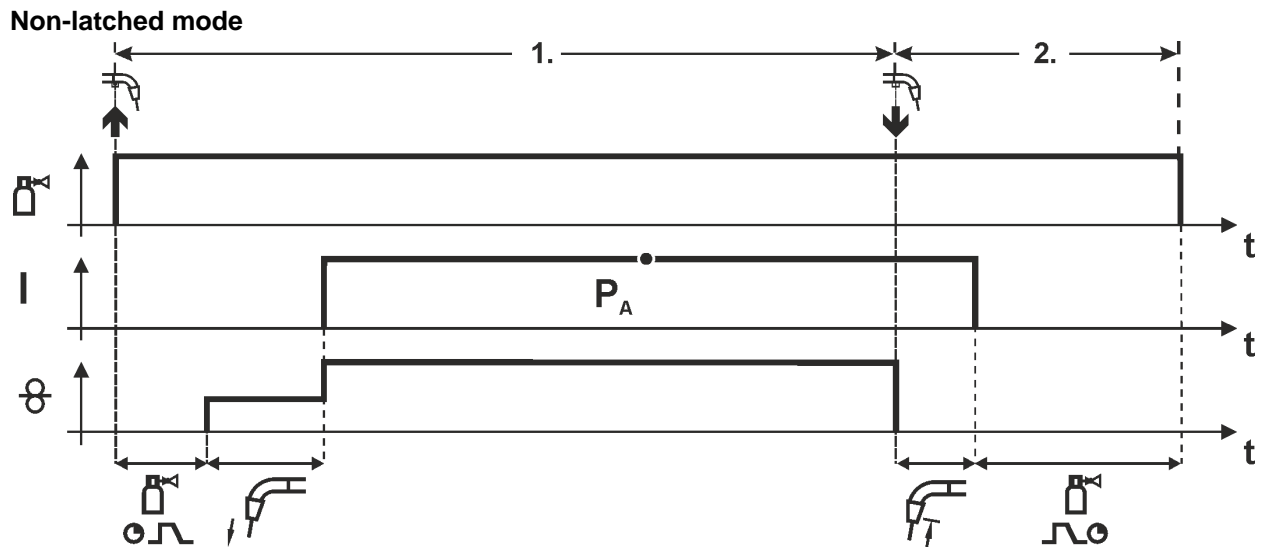

Figure 5-13

Step 1

- Press and hold torch trigger.
- Shielding gas is expelled (gas pre-flows).
- Wire feed motor runs at “creep speed”.
- Arc ignites after the wire electrode makes contact with the workpiece; welding current flows.
- Change over to pre-selected wire speed.

Step 2

- Release torch trigger.
- WF motor stops.
- Arc is extinguished after the preselected wire burn-back time expires.
- Gas post-flow time elapses.

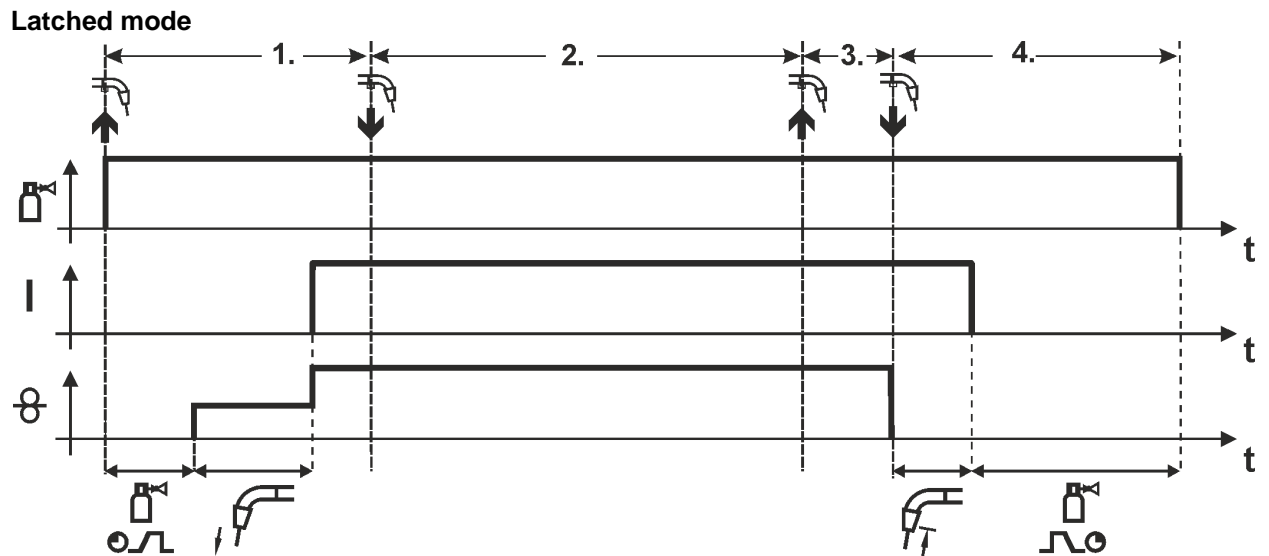

Figure 5-14

Step 1

- Press and hold torch trigger
- Shielding gas is expelled (gas pre-flows)
- Wire feed motor runs at “creep speed”.
- Arc ignites after the wire electrode makes contact with the workpiece; welding current flows.
- Change over to pre-selected WF speed (main program P_A).

Step 2

- Release torch trigger (no effect)

Step 3

- Press torch trigger (no effect)

Step 4

- Release torch trigger
- WF motor stops.
- Arc is extinguished after the preselected wire burn-back time expires.
- Gas post-flow time elapses.

5.4 MMA welding

⚠ CAUTION



Risk of being crushed or burnt.

When replacing spent or new stick electrodes

- Switch off machine at the main switch
- Wear appropriate safety gloves
- Use insulated tongs to remove spent stick electrodes or to move welded workpieces and
- Always put the electrode holder down on an insulated surface.

5.4.1 Connecting the electrode holder and workpiece lead

Polarity depends on the instructions from the electrode manufacturer given on the electrode packaging.

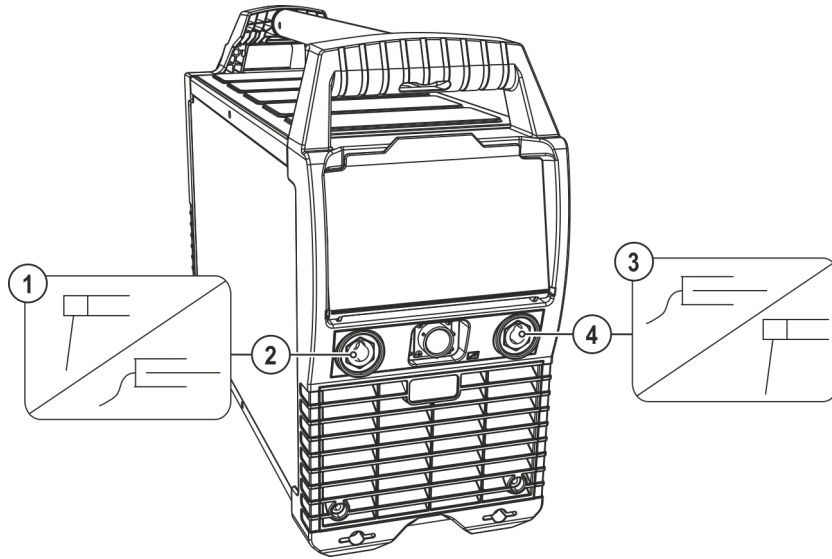

Figure 5-15

| Item | Symbol | Description |
|------|--------|---|
| 1 | | Electrode holder |
| 2 | | Connection socket for "+" welding current Electrode holder or workpiece lead connection |
| 3 | | Workpiece |
| 4 | | Connection socket, "-" welding current Workpiece lead or electrode holder connection |

- Insert cable plug of the electrode holder into either the "+" or "-" welding current connection socket and lock by turning to the right.
- Insert cable plug of the workpiece lead into either the "+" or "-" welding current connection socket and lock by turning to the right.

5.4.2 Welding task selection

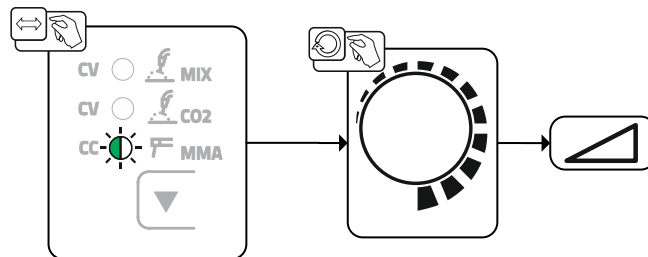

Figure 5-16

5.4.2.1 Arcforce

During the welding process, arcforce prevents the electrode sticking in the weld pool with increases in current. This makes it easier to weld large-drop melting electrode types at low current strengths with a short arc in particular.

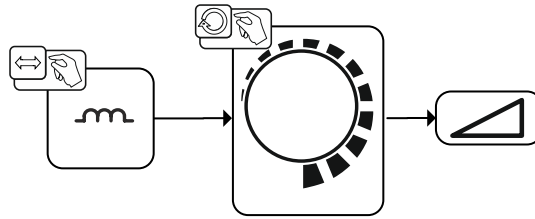

Figure 5-17

5.4.2.2 Hotstart

The hotstart device improves the ignition of the stick electrodes using an increased ignition current.

- a) = Hotstart time
- b) = Hotstart current
- I = Welding current
- t = Time

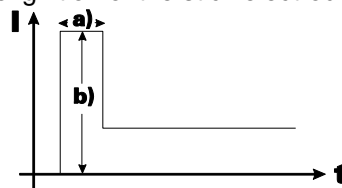
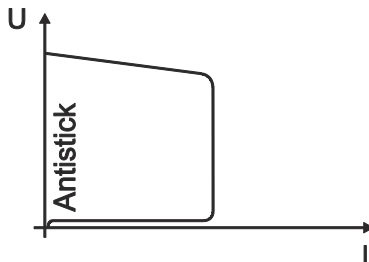

Figure 5-18

 For parameter setting, > see 5.4.4 chapter.

5.4.2.3 Antistick



Anti-stick prevents the electrode from annealing.

If the electrode sticks in spite of the Arcforce device, the machine automatically switches over to the minimum current within about 1 second to prevent the electrode from overheating. Check the welding current setting and correct according to the welding task!

Figure 5-19

5.4.3 Arc length restriction (USP)

The arc length restriction **USP** function stops the welding process when an excessive arc voltage is detected (unusually high gap between electrode and workpiece). The function can be switched on or off, depending on the process > see 5.4.4 chapter.

5.4.4 Expert menu (MMA)

The Expert menu has adjustable parameters stored that don't require regular setting. The number of parameters shown may be limited, e.g. if a function is deactivated.

The setting ranges for the parameter values are summarised in the Parameter overview section > see 10.1 chapter.

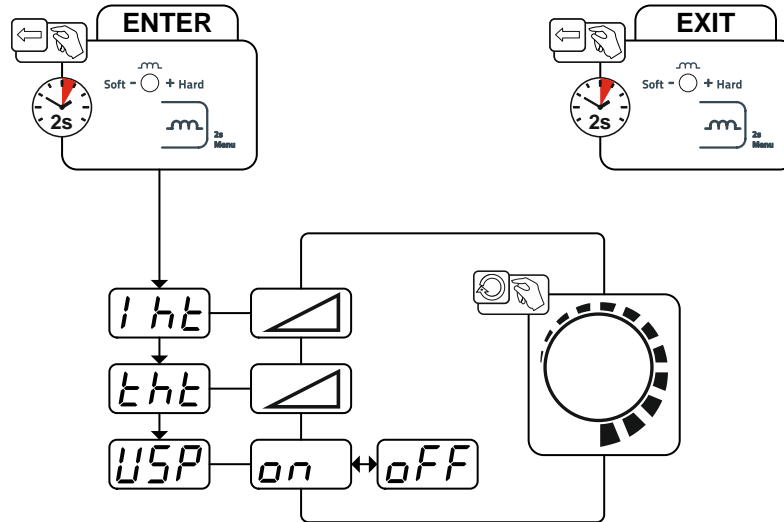

Figure 5-20

| Display | Setting/selection |
|---------|---|
| | Hotstart current |
| | Hotstart time |
| | Arc length restriction > see 5.4.3 chapter ----- Function switched on ----- Function switched off |

5.5 Remote control

The remote controls are operated on the 19-pole remote control connection socket (analogue).

5.5.1 RT1 19POL



Functions

- Infinitely adjustable welding current (0% to 100%) depending on the preselected main current on the welding machine.

5.5.2 RTG1 19POL

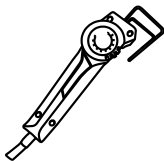

Functions

- Infinite setting of the welding current (0% to 100%) depending on the main current preselected at the welding machine

5.6 Power-saving mode (Standby)

You can activate the power-saving mode by either pressing the push-button > see 4.3 chapter for a prolonged time or by setting a parameter in the machine configuration menu (time-controlled power-saving mode **SbA**) > see 5.7 chapter.



When power-saving mode is activated, the machine displays show the horizontal digit in the centre of the display only.

Pressing any operating element (e.g. tapping the torch trigger) deactivates power-saving mode and the machine is ready for welding again.

5.7 Machine configuration menu

5.7.1 Selecting, changing and saving parameters



ENTER (Enter the menu)

- Switch off the machine at the main switch.
- Press and hold the "Sequence parameter" push-button and switch the machine on again at the same time. Wait until the "End" menu item is shown and release the push-button.

EXIT (Exit the menu)

- Select menu item End.
- Press the "Sequence parameter" push-button (settings will be applied, machine changes to the ready-to-operate status).

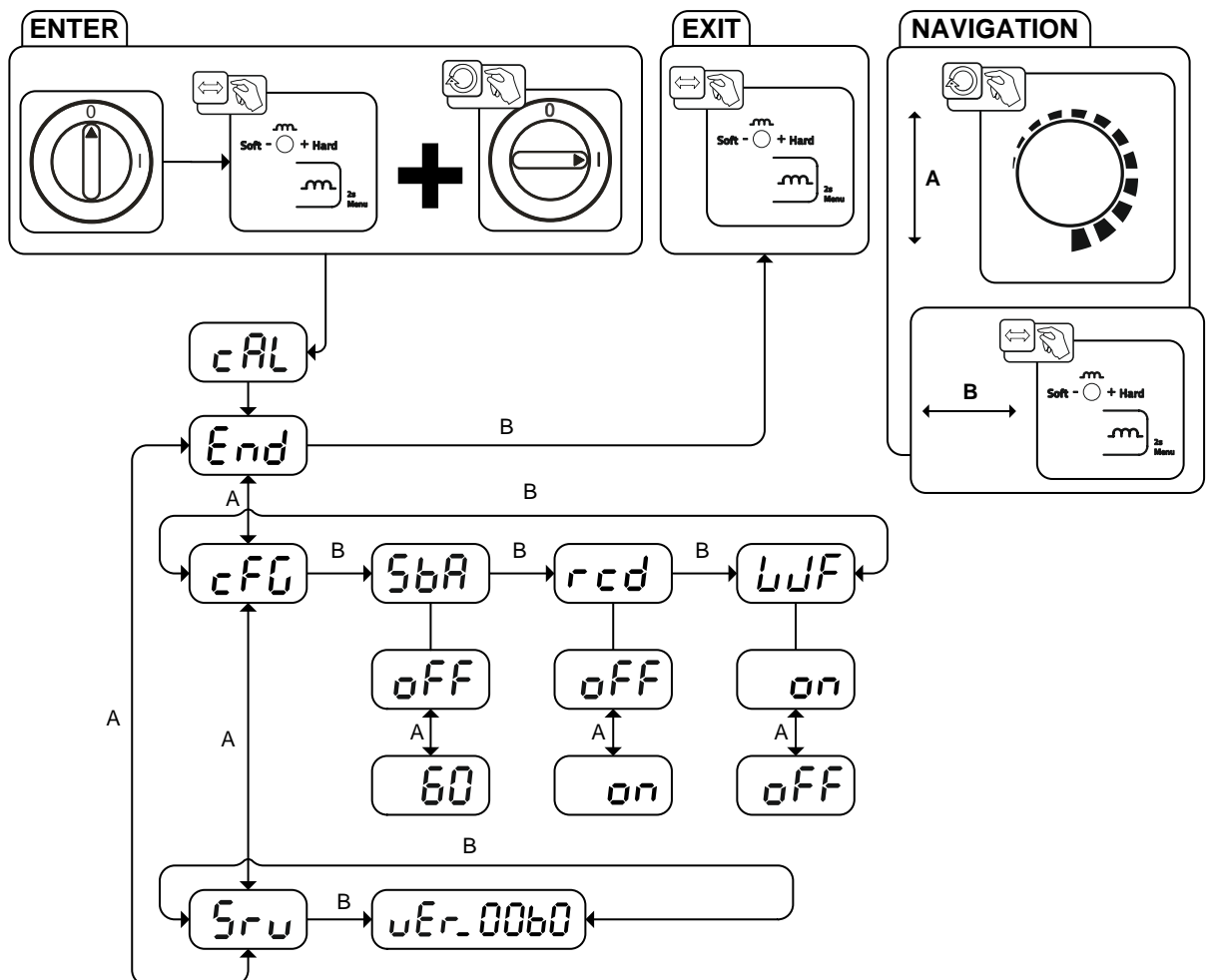

Figure 5-21

| Display | Setting/selection |
|---------|--|
| | Calibration The machine will be calibrated for approx 2 seconds each time it is switched on. |

| Display | Setting/selection |
|------------|---|
| End | Exit the menu Exit |
| cFG | Machine configuration Settings for machine functions and parameter display |
| SbA | Time-based power-saving mode > see 5.6 chapter 5 min.–60 min. = Time to activation of power-saving mode in case of inactivity. <input type="checkbox"/> FF----- inactivated |
| rCd | Current display switching (MMA) <input type="checkbox"/> ----- Actual value display <input type="checkbox"/> FF----- Nominal value display (ex works) |
| WUF | Use of accessories <input type="checkbox"/> ----- Operation with wire feeder (ex works) <input type="checkbox"/> FF----- Operation with foot-operated remote control |
| SrU | Service menu Any changes to the service menu should be agreed with the authorised service personnel. |
| uEr | Software version of the machine control Version display |

6 Maintenance, care and disposal

6.1 General

DANGER



Incorrect maintenance and testing!

The machine may be cleaned, repaired and tested by skilled and qualified personnel only. A qualified person is one who, due to their training, knowledge and experience, can detect any hazards and possible consequential damage when checking the machine, and can take the necessary safety measures.

- Observe the maintenance instructions > see 6.3 chapter!
- The machine may only be put into operation again once the testing has been successful.



Risk of injury due to electrical voltage after switching off!

Working on an open machine can lead to fatal injuries!

Capacitors are loaded with electrical voltage during operation. Voltage remains present for up to four minutes after the mains plug is removed.

1. Switch off machine.
2. Remove the mains plug.
3. Wait for at last 4 minutes until the capacitors have discharged!

WARNING



Cleaning, testing and repair!

Cleaning, testing and repairing of the welding machine may only be carried out by competent, qualified personnel. A qualified person is one who, because of his or her training, knowledge and experience, is able to recognise the dangers that can occur while testing welding power sources as well as possible subsequent damage, and who is able to implement the required safety procedures.

- In the event of failure of any one of the following tests, the machine must not be operated again until it has been repaired and a new test has been carried out.

Repair and maintenance work may only be performed by qualified authorised personnel; otherwise the right to claim under warranty is void. In all service matters, always consult the dealer who supplied the machine. Return deliveries of defective equipment subject to warranty may only be made through your dealer. When replacing parts, use only original spare parts. When ordering spare parts, please quote the machine type, serial number and item number of the machine, as well as the type designation and item number of the spare part.

Under the specified ambient conditions and normal working conditions this machine is essentially maintenance-free and requires just a minimum of care.

Contamination of the machine may impair service life and duty cycle. The cleaning intervals depend on the ambient conditions and the resulting contamination of the machine. The minimum interval is every six months.

6.2 Cleaning

- Clean the outer surfaces with a moist cloth (no aggressive cleaning agents).
- Purge the machine venting channel and cooling fins (if present) with oil- and water-free compressed air. Compressed air may overspeed and destroy the machine fans. Never direct the compressed air directly at the machine fans. Mechanically block the fans, if required.
- Check the coolant for contaminants and replace, if necessary.

6.3 Maintenance work, intervals

Repair and maintenance work may only be performed by qualified authorised personnel; otherwise the right to claim under warranty is void. In all service matters, always consult the dealer who supplied the machine. Return deliveries of defective equipment subject to warranty may only be made through your dealer. When replacing parts, use only original spare parts. When ordering spare parts, please quote the machine type, serial number and item number of the machine, as well as the type designation and item number of the spare part.

6.3.1 Daily maintenance tasks

6.3.1.1 Visual inspection

- Mains supply lead and its strain relief
- Gas cylinder securing elements
- Check hose package and power connections for exterior damage and replace or have repaired by specialist staff as necessary!
- Gas tubes and their switching equipment (solenoid valve)
- Check that all connections and wearing parts are hand-tight and tighten if necessary.
- Check correct mounting of the wire spool.
- Wheels and their securing elements
- Transport elements (strap, lifting lugs, handle)
- Other, general condition

6.3.1.2 Functional test

- Operating, message, safety and adjustment devices (Functional test)
- Welding current cables (check that they are fitted correctly and secured)
- Gas tubes and their switching equipment (solenoid valve)
- Gas cylinder securing elements
- Check correct mounting of the wire spool.
- Check that all screw and plug connections and replaceable parts are secured correctly, tighten if necessary.
- Remove any spatter.
- Clean the wire feed rollers on a regular basis (depending on the degree of soiling).

6.3.2 Monthly maintenance tasks

6.3.2.1 Visual inspection

- Casing damage (front, rear and side walls)
- Wheels and their securing elements
- Transport elements (strap, lifting lugs, handle)
- Check coolant tubes and their connections for impurities

6.3.2.2 Functional test

- Selector switches, command devices, emergency stop devices, voltage reducing devices, message and control lamps
- Check that the wire guide elements (inlet nipple, wire guide tube) are fitted securely.
- Check coolant tubes and their connections for impurities
- Check and clean the welding torch. Deposits in the torch can cause short circuits and have a negative impact on the welding result, ultimately causing damage to the torch.

6.3.3 Annual test (inspection and testing during operation)



The welding machine may only be tested by competent, capable persons! A capable person is one who, because of his training, knowledge and experience, is able to recognise the dangers that can occur while testing welding power sources as well as possible subsequent damage and who is able to implement the required safety procedures.



For more information refer to the "Warranty registration" brochure supplied and our information regarding warranty, maintenance and testing at www.ewm-group.com!

A periodic test according to IEC 60974-4 "Periodic inspection and test" has to be carried out. In addition to the regulations on testing given here, the relevant local laws and regulations must also be observed.

6.4 Disposing of equipment



Proper disposal!

The machine contains valuable raw materials, which should be recycled, and electronic components, which must be disposed of.

- **Do not dispose of in household waste!**
- **Observe the local regulations regarding disposal!**



6.4.1 Manufacturer's declaration to the end user

- According to European provisions (guideline 2012/19/EU of the European Parliament and the Council of Juli, 4th 2021), used electric and electronic equipment may no longer be placed in unsorted municipal waste. It must be collected separately. The symbol depicting a waste container on wheels indicates that the equipment must be collected separately.
This machine is to be placed for disposal or recycling in the waste separation systems provided for this purpose.
- According to German law (law governing the distribution, taking back and environmentally correct disposal of electric and electronic equipment (ElektroG) from 16.03.2005), used machines are to be placed in a collection system separate from unsorted municipal waste. The public waste management utilities (communities) have created collection points at which used equipment from private households can be disposed of free of charge.
- Information about giving back used equipment or about collections can be obtained from the respective municipal administration office.
- EWM participates in an approved waste disposal and recycling system and is registered in the Used Electrical Equipment Register (EAR) under number WEEE DE 57686922.
- In addition to this, returns are also possible throughout Europe via EWM sales partners.

6.5 Meeting the requirements of RoHS

We, EWM AG in Mündersbach, Germany, hereby confirm that all products which we supply to you and that are subject to the RoHS directive comply with RoHS requirements (also see applicable EC directives on the Declaration of Conformity on your machine).

7 Rectifying faults

All products are subject to rigorous production checks and final checks. If, despite this, something fails to work at any time, please check the product using the following flowchart. If none of the fault rectification procedures described leads to the correct functioning of the product, please inform your authorised dealer.

7.1 Checklist for rectifying faults



The correct machine equipment for the material and process gas in use is a fundamental requirement for perfect operation!

| Legend | Symbol | Description |
|--------|--------|-------------|
| | ↘ | Fault/Cause |
| | ✘ | Remedy |

Wire feed problems

- ↘ Contact tip blocked
 - ✘ Clean, spray with anti-spatter spray and replace if necessary
- ↘ Setting the spool brake
 - ✘ Check settings and correct if necessary
- ↘ Setting pressure units
 - ✘ Check settings and correct if necessary
- ↘ Worn wire rolls
 - ✘ Check and replace if necessary
- ↘ Wire feed motor without supply voltage (automatic cutout triggered by overloading)
 - ✘ Reset triggered fuse (rear of the power source) by pressing the key button
- ↘ Kinked hose packages
 - ✘ Extend and lay out the torch hose package
- ↘ Wire guide core or spiral is dirty or worn
 - ✘ Clean core or spiral; replace kinked or worn cores

Functional errors

- ↘ All machine control signal lights are illuminated after switching on
- ↘ No machine control signal light is illuminated after switching on
- ↘ No welding power
 - ✘ Phase failure > check mains connection (fuses)
- ↘ Several parameters cannot be set (machines with access block)
 - ✘ Entry level is blocked, disable access lock
- ↘ Connection problems
 - ✘ Make control lead connections and check that they are fitted correctly.
- ↘ Loose welding current connections
 - ✘ Tighten power connections on the torch and/or on the workpiece
 - ✘ Tighten contact tip correctly

7.2 Error messages (power source)

 **A welding machine error is indicated by an error code being displayed (see table) on the display on the machine control.**

In the event of a machine error, the power unit is shut down.

 **The display of possible error numbers depends on the machine version (interfaces/functions).**

- If multiple errors occur, these are displayed in succession.
- Document machine errors and inform service staff as necessary.

| Error message | Possible cause | Remedy |
|---------------|---|--|
| E 0 | Start signal set in the event of errors | Do not press the torch trigger or the foot-operated remote control |
| E 4 | Temperature error | Allow the machine to cool down |
| E 5 | Mains overvoltage | Switch off the machine and check the mains voltage |
| E 6 | Mains undervoltage | |
| E 7 | Electronics error | Switch the machine on and off again. |
| E 9 | Secondary overvoltage | If the error persists, notify service department |
| E12 | Voltage reduction error (VRD) | |
| E13 | Electronics error | |
| E14 | Adjustment error in current recording | Switch off the machine, place the electrode holder in an insulated position and switch the machine back on. If the error persists, notify service department |
| E15 | Error in one of the electronics supply voltages | Switch the machine off and on again. If the error persists, notify service department |
| E23 | Temperature error | Allow the machine to cool down |
| E32 | Electronics error | Switch the machine on and off again. If the error persists, notify service department |
| E33 | Adjustment error in voltage recording | Switch off the machine, place the electrode holder in an insulated position and switch the machine back on. If the error persists, notify service department |
| E34 | Electronics error | Switch the machine on and off again. If the error persists, notify service department |
| E37 | Temperature error | Allow the machine to cool down |
| E40 | Motor fault | Check wire feed unit, switch the machine off and on again, inform the service department if the fault persists. |
| E55 | Failure of a mains phase | Switch off the machine and check the mains voltage |
| E58 | Short circuit in welding circuit | Switch off machine and check welding current leads for correct installation, e.g., put down electrode holder in an electrically insulated manner, disconnect degausser current lead. |

7.3 Resetting welding parameters to the factory settings

All customised welding parameters that are stored will be replaced by the factory settings.

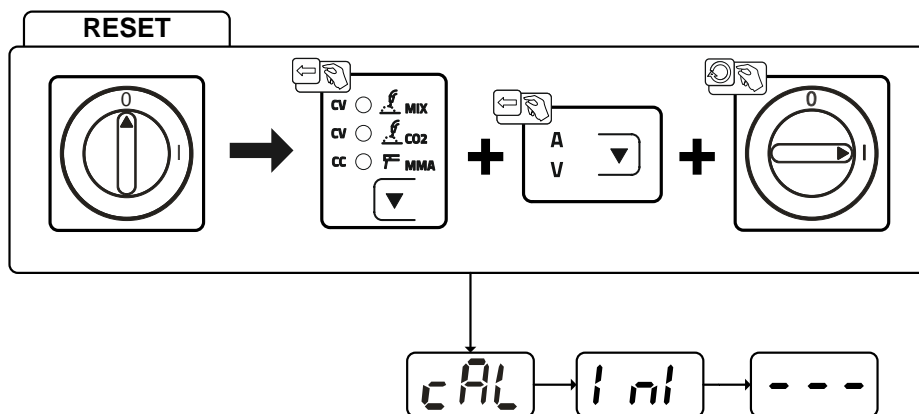

Figure 7-1

| Display | Setting/selection |
|---------|--|
| | Calibration The machine will be calibrated for approx 2 seconds each time it is switched on. |
| | Initialising Keep the push-button pressed until "lnl" is shown on the display. |

8 Technical data



Performance specifications and guarantee only in connection with original spare and replacement parts!

8.1 Taurus 400 Basic TDG

| Setting range | MIG/MAG | MMA |
|--|---|----------------|
| Welding current | 10 A to 400 A | |
| Welding voltage | 14.5 V to 34 V | 20.4 V to 36 V |
| Duty cycle at 40 °C ambient temperature | | |
| 30% DC | 400 A | |
| 60% DC | 280 A | |
| 100% DC | 230 A | |
| Load cycle | 10 min. (60% DC \pm 6 min. welding, 4 min. pause) | |
| Open circuit voltage | 80 V | |
| Mains voltage (tolerances) | 3 x 400 V (-25% to +20%) | |
| Frequency | 50/60 Hz | |
| Mains fuse (safety fuse, slow-blow) | 3 x 16 A | |
| Mains connection lead | H07RN-F4G2,5 | |
| Max. connected load | 17.2 kVA | 18.2 kVA |
| Recommended generator rating | 24.6 kVA | |
| cos ϕ /efficiency | 0.99/88% | |
| Machine cooling/torch cooling | Fan (AF)/gas | |
| Workpiece lead | 50 mm ² | |
| Insulation class/protection classification | H/IP 34s | |
| EMC class | A | |
| Safety identification |  | |
| Harmonised standards used | IEC 60974-1,-10 | |
| Dimensions L x W x H | 539 mm x 210 mm x 415 mm | |
| | 21.2 inch x 8.3 inch x 16.3 inch | |
| Weight (without mains cable) | 23.5 kg | |
| | 51.8 lb | |

9 Accessories



Performance-dependent accessories like torches, workpiece leads, electrode holders or intermediate hose packages are available from your authorised dealer.

9.1 System components

9.1.1 Wire feed unit

| Type | Designation | Item no. |
|-----------------------|-------------|------------------|
| Taurus drive 4L Basic | Wire feeder | 090-005447-00502 |

9.2 Options

| Type | Designation | Item no. |
|--------------------|---------------------------|------------------|
| ON Filter Pico 350 | Dirt filter for air inlet | 092-002756-00000 |

9.3 Remote controls and accessories

| Type | Designation | Item no. |
|------------------|--------------------------------------|------------------|
| RT1 19POL | Remote control current | 090-008097-00000 |
| RTG1 19POL 5m | Remote control, current | 090-008106-00000 |
| RTG1 19POL 10m | Remote control, current | 090-008106-00010 |
| RV5M19 19POLE 5M | Extension cable | 092-000857-00000 |
| RA10 19POL 10M | Remote control e.g. connection cable | 092-001470-00010 |
| RA20 19POL 20M | Remote control e.g. connection cable | 092-001470-00020 |

9.4 General accessories

| Type | Designation | Item no. |
|----------------------------|-----------------------------------|------------------|
| DM 842 Ar/CO2 230bar 30l D | Pressure regulator with manometer | 394-002910-00030 |
| 5POLE/CEE/32A/M | Machine plug | 094-000207-00000 |
| RV5M19 19POLE 5M | Extension cable | 092-000857-00000 |

10 Appendix A

10.1 Parameter overview – setting information

| Welding data display (3-digit) | Parameters/function | Setting range | | | |
|--|---|------------------------|------------|------|------|
| | | Standard (ex works) | Min. | Max. | Unit |
| MIG/MAG | | | | | |
| | Welding voltage | 10 | 10 - 49,9 | V | |
| | Dynamic correction | 0 | -40 - 40 | | |
| MMA | | | | | |
| | Main current | 10 | 10 - 400 | A | |
| | Arcforce correction | 0 | -10 - 20 | | |
| I h t | Hot start current | 120 | 50 - 200 | % | |
| t h t | Hot start time | 0,5 | 0,1 - 20,0 | s | |
| U S P | Arc length restriction | off | on / off | | |
| Basic parameters (independent of procedure) | | | | | |
| - 0 - | Power-saving mode active | | | | |
| End | Exit menu | | | | |
| c F G | Machine configuration | | | | |
| U J F | Use of accessories | on | on / off | | |
| S b R | Time-based power-saving mode | off | 5 - 60 | min. | |
| r c d | Current display switching (MMA) | | | | |
| S r u | Service menu | | | | |
| u E r | Software version of the machine control | | | | |

11 Appendix B

11.1 Overview of EWM branches

Headquarters

EWM AG
Dr. Günter-Henle-Straße 8
56271 Mündersbach · Germany
Tel: +49 2680 181-0 · Fax: -244
www.ewm-group.com · info@ewm-group.com

Technology centre

EWM AG
Forststraße 7-13
56271 Mündersbach · Germany
Tel: +49 2680 181-0 · Fax: -144
www.ewm-group.com · info@ewm-group.com

Production, Sales and Service

EWM AG
Dr. Günter-Henle-Straße 8
56271 Mündersbach · Germany
Tel: +49 2680 181-0 · Fax: -244
www.ewm-group.com · info@ewm-group.com

EWM HIGHTEC WELDING s.r.o.
9. května 718 / 31
407 53 Jiřikov · Czech Republic
Tel.: +420 412 358-551 · Fax: -504
www.ewm-jirikov.cz · info@ewm-jirikov.cz

EWM HIGH TECHNOLOGY (Kunshan) Ltd.
10 Yuanshan Road, Kunshan · New & Hi-tech Industry Development Zone
Kunshan City · Jiangsu · Post code 215300 · People's Republic of China
Tel: +86 512 57867-188 · Fax: -182
www.ewm.cn · info@ewm.cn · info@ewm-group.cn

Sales and Service Germany

EWM AG
Sales and Technology Centre
Grünauer Fenn 4
14712 Rathenow · Tel: +49 3385 49402-0 · Fax: -20
www.ewm-rathenow.de · info@ewm-rathenow.de

EWM HIGHTEC WELDING GmbH
Centre Technology and mechanisation
Daimlerstr. 4-6
69469 Weinheim · Tel: +49 6201 84557-0 · Fax: -20
www.ewm-weinheim.de · info@ewm-weinheim.de

EWM AG
Rudolf-Winkel-Straße 7-9
37079 Göttingen · Tel: +49 551-3070713-0 · Fax: -20
www.ewm-goettingen.de · info@ewm-goettingen.de

EWM Schweißtechnik Handels GmbH
Karlsdorfer Straße 43
88069 Tettngang · Tel: +49 7542 97998-0 · Fax: -29
www.ewm-tettngang.de · info@ewm-tettngang.de

EWM AG
Dieselstraße 9b
50259 Pulheim · Tel: +49 2238-46466-0 · Fax: -14
www.ewm-pulheim.de · info@ewm-pulheim.de

EWM Schweißtechnik Handels GmbH
Heinkelstraße 8
89231 Neu-Ulm · Tel: +49 731 7047939-0 · Fax: -15
www.ewm-neu-ulm.de · info@ewm-neu-ulm.de

EWM AG
August-Horch-Straße 13a
56070 Koblenz · Tel: +49 261 963754-0 · Fax: -10
www.ewm-koblenz.de · info@ewm-koblenz.de

EWM AG
Eiserfelder Straße 300
57080 Siegen · Tel: +49 271 3878103-0 · Fax: -9
www.ewm-siegen.de · info@ewm-siegen.de

Sales and Service International

EWM HIGH TECHNOLOGY (Kunshan) Ltd.
10 Yuanshan Road, Kunshan · New & Hi-tech Industry Development Zone
Kunshan City · Jiangsu · Post code 215300 · People's Republic of China
Tel: +86 512 57867-188 · Fax: -182
www.ewm.cn · info@ewm.cn · info@ewm-group.cn

EWM HIGHTEC WELDING UK Ltd.
Unit 2B Coopies Way · Coopies Lane Industrial Estate
Morpeth · Northumberland · NE61 6JN · Great Britain
Tel: +44 1670 505875 · Fax: -514305
www.ewm-morpeth.co.uk · info@ewm-morpeth.co.uk

EWM HIGHTEC WELDING GmbH
Wiesenstraße 27b
4812 Pinsdorf · Austria · Tel: +43 7612 778 02-0 · Fax: -20
www.ewm-austria.at · info@ewm-austria.at

EWM HIGHTEC WELDING Sales s.r.o. / Prodejní a poradenské centrum
Tyršova 2106
256 01 Benešov u Prahy · Czech Republic
Tel: +420 317 729-517 · Fax: -712
www.ewm-benesov.cz · info@ewm-benesov.cz

Liaison office Turkey

EWM AG Türkiye İrtibat Bürosu
İkitelli OSB Mah. · Marmara Sanayi Sitesi P Blok Apt. No: 44
Küçükçekmece / İstanbul Türkiye
Tel.: +90 212 494 32 19
www.ewm-istanbul.com.tr · info@ewm-istanbul.com.tr

