



EN

Welding machine

Taurus 351 Basic FKG

Taurus 401 Basic FKG

Taurus 351 Basic FKW

Taurus 401 Basic FKW

Taurus 501 Basic FKW

099-005425-EW501

14.07.2016

**Register now
and benefit!**
**Jetzt Registrieren
und Profitieren!**

www.ewm-group.com

3 Years

5 Years
transformer
and rectifier

ewm-warranty*
24 hours / 7 days

* For details visit
www.ewm-group.com

General instructions

WARNING



Read the operating instructions!

The operating instructions provide an introduction to the safe use of the products.

- Read and observe the operating instructions for all system components, especially the safety instructions and warning notices!
- Observe the accident prevention regulations and any regional regulations!
- The operating instructions must be kept at the location where the machine is operated.
- Safety and warning labels on the machine indicate any possible risks. Keep these labels clean and legible at all times.
- The machine has been constructed to state-of-the-art standards in line with any applicable regulations and industrial standards. Only trained personnel may operate, service and repair the machine.
- Technical changes due to further development in machine technology may lead to a differing welding behaviour.



In the event of queries on installation, commissioning, operation or special conditions at the installation site, or on usage, please contact your sales partner or our customer service department on +49 2680 181-0.

A list of authorised sales partners can be found at www.ewm-group.com.

Liability relating to the operation of this equipment is restricted solely to the function of the equipment. No other form of liability, regardless of type, shall be accepted. This exclusion of liability shall be deemed accepted by the user on commissioning the equipment.

The manufacturer is unable to monitor whether or not these instructions or the conditions and methods are observed during installation, operation, usage and maintenance of the equipment.

An incorrectly performed installation can result in material damage and injure persons as a result. For this reason, we do not accept any responsibility or liability for losses, damages or costs arising from incorrect installation, improper operation or incorrect usage and maintenance or any actions connected to this in any way.

© EWM AG

Dr. Günter-Henle-Straße 8

56271 Mündersbach

Germany

The copyright to this document remains the property of the manufacturer.

Copying, including extracts, only permitted with written approval.

The content of this document has been prepared and reviewed with all reasonable care. The information provided is subject to change; errors excepted.

1 Contents

1	Contents	3
2	Safety instructions	6
2.1	Notes on the use of these operating instructions	6
2.2	Explanation of icons	7
2.3	Safety instructions	8
2.4	Transport and installation	12
3	Intended use	13
3.1	Documents which also apply	13
3.1.1	Warranty	13
3.1.2	Declaration of Conformity	13
3.1.3	Welding in environments with increased electrical hazards	13
3.1.4	Service documents (spare parts and circuit diagrams)	13
3.1.5	Calibration/Validation	13
4	Machine description – quick overview	14
4.1	Front view	14
4.2	Rear view	16
4.3	Inside view	18
4.4	Machine control – Operating elements	19
5	Design and function	21
5.1	Transport and installation	21
5.1.1	Lifting by crane	21
5.1.2	Ambient conditions	22
5.1.2.1	In operation	22
5.1.2.2	Transport and storage	22
5.1.3	Machine cooling	22
5.1.4	Workpiece lead, general	22
5.1.5	Welding torch cooling system	23
5.1.5.1	Approved coolants overview	23
5.1.5.2	Maximal hose package length	23
5.1.5.3	Adding coolant	24
5.1.6	Notes on the installation of welding current leads	25
5.1.7	Stray welding currents	26
5.1.8	Mains connection	27
5.1.8.1	Mains configuration	27
5.1.9	Shielding gas supply (shielding gas cylinder for welding machine)	28
5.1.9.1	Pressure regulator connection	28
5.1.9.2	Shielding gas hose connection	29
5.1.9.3	Gas test – setting the shielding gas volume	30
5.1.9.4	Rinse hose package function	30
5.2	Welding data display	31
5.3	MIG/MAG welding	32
5.3.1	Welding torch and workpiece line connection	32
5.3.2	Wire feed	35
5.3.2.1	Open the protective flap of the wire feeder	35
5.3.2.2	Inserting the wire spool	36
5.3.2.3	Changing the wire feed rollers	37
5.3.2.4	Inching the wire electrode	39
5.3.2.5	Spool brake setting	40
5.3.3	Welding task selection	41
5.3.3.1	Accessory components for operating point setting	41
5.3.4	Further welding parameters	42
5.3.5	MIG/MAG functional sequences / operating modes	43
5.3.5.1	Explanation of signs and functions	43
5.3.6	Standard MIG/MAG torch	45
5.3.7	MIG/MAG special-torches	45
5.4	MMA welding	46

5.4.1	Connecting the electrode holder and workpiece lead	47
5.4.2	Welding task selection	48
5.4.3	Arcforce.....	48
5.4.4	Hotstart	48
5.4.5	Antistick.....	48
5.4.6	Air arc gouging.....	49
	5.4.6.1 Connection	49
5.4.7	Welding task selection	50
5.5	Remote control.....	51
5.6	Special parameters (advanced settings).....	51
5.6.1	Selecting, changing and saving parameters.....	51
	5.6.1.1 Reset to factory settings.....	53
	5.6.1.2 Special parameters in detail	53
5.7	Machine configuration menu	54
5.7.1	Selecting, changing and saving parameters.....	54
5.7.2	Power-saving mode (Standby)	55
5.7.3	Aligning the cable resistance.....	55
6	Maintenance, care and disposal	57
6.1	General.....	57
6.2	Cleaning	57
6.3	Maintenance work, intervals	58
6.3.1	Daily maintenance tasks.....	58
	6.3.1.1 Visual inspection	58
	6.3.1.2 Functional test	58
6.3.2	Monthly maintenance tasks	58
	6.3.2.1 Visual inspection	58
	6.3.2.2 Functional test.....	58
6.3.3	Annual test (inspection and testing during operation)	59
6.4	Disposing of equipment.....	59
	6.4.1 Manufacturer's declaration to the end user	59
6.5	Meeting the requirements of RoHS.....	59
7	Rectifying faults.....	60
7.1	Checklist for rectifying faults	60
7.2	Error messages (power source).....	61
7.3	Welding parameter calibration	63
7.4	Vent coolant circuit.....	64
8	Technical data.....	65
8.1	Taurus 351 FKG.....	65
8.2	Taurus 401 FKG.....	66
8.3	Taurus 351 FKW	67
8.4	Taurus 401 FKW	68
8.5	Taurus 501 FKW	69
9	Accessories	70
9.1	General accessories	70
9.2	Remote control / connection cable.....	70
9.3	Options.....	70
10	Replaceable parts.....	71
10.1	Wire feed rollers	71
	10.1.1 Wire feed rollers for steel wire	71
	10.1.2 Wire feed rollers for aluminium wire	72
	10.1.3 Wire feed rollers for cored wire.....	72
	10.1.4 Wire guide.....	72
11	Appendix A.....	73
11.1	Setting instructions.....	73
12	Appendix B.....	74
12.1	Overview of EWM branches.....	74

2 Safety instructions

2.1 Notes on the use of these operating instructions

DANGER

Working or operating procedures which must be closely observed to prevent imminent serious and even fatal injuries.

- Safety notes include the "DANGER" keyword in the heading with a general warning symbol.
- The hazard is also highlighted using a symbol on the edge of the page.

WARNING

Working or operating procedures which must be closely observed to prevent serious and even fatal injuries.

- Safety notes include the "WARNING" keyword in the heading with a general warning symbol.
- The hazard is also highlighted using a symbol in the page margin.

CAUTION

Working or operating procedures which must be closely observed to prevent possible minor personal injury.

- The safety information includes the "CAUTION" keyword in its heading with a general warning symbol.
- The risk is explained using a symbol on the edge of the page.



Special technical points which users must observe.

Instructions and lists detailing step-by-step actions for given situations can be recognised via bullet points, e.g.:

- Insert the welding current lead socket into the relevant socket and lock.

2.2 Explanation of icons

Symbol	Description	Symbol	Description
	Indicates technical aspects which the user must observe.		Activate and release/tap/tip
	Switch off machine		Release
	Switch on machine		Press and keep pressed
			Switch
	Wrong		Turn
	Correct		Numerical value – adjustable
	Menu entry		Signal light lights up in green
	Navigating the menu		Signal light flashes green
	Exit menu		Signal light lights up in red
	Time representation (e.g.: wait 4 s/activate)		Signal light flashes red
	Interruption in the menu display (other setting options possible)		
	Tool not required/do not use		
	Tool required/use		

2.3 Safety instructions

WARNING



Risk of accidents due to non-compliance with the safety instructions!

Non-compliance with the safety instructions can be fatal!

- Carefully read the safety instructions in this manual!
- Observe the accident prevention regulations and any regional regulations!
- Inform persons in the working area that they must comply with the regulations!

WARNING



Risk of injury from electrical voltage!

Voltages can cause potentially fatal electric shocks and burns on contact. Even low voltages can cause a shock and lead to accidents.

- Never touch live components such as welding current sockets or stick, tungsten or wire electrodes!
- Always place torches and electrode holders on an insulated surface!
- Wear the full personal protective equipment (depending on the application)!
- The machine may only be opened by qualified personnel!



Hazard when interconnecting multiple power sources!

If a number of power sources are to be connected in parallel or in series, only a technical specialist may interconnect the sources as per standard *IEC 60974-9:2010: Installation and use* and German Accident Prevention Regulation BVD D1 (formerly VBG 15) or country-specific regulations.

Before commencing arc welding, a test must verify that the equipment cannot exceed the maximum permitted open circuit voltage.

- Only qualified personnel may connect the machine.
- When taking individual power sources out of operation, all mains and welding current leads must be safely disconnected from the welding system as a whole. (Hazard due to reverse polarity voltage!)
- Do not interconnect welding machines with pole reversing switch (PWS series) or machines for AC welding since a minor error in operation can cause the welding voltages to be combined, which is not permitted.

⚠ WARNING**Risk of injury due to improper clothing!**

During arc welding, radiation, heat and voltage are sources of risk that cannot be avoided. The user has to be equipped with the complete personal protective equipment at all times. The protective equipment has to include:

- Respiratory protection against hazardous substances and mixtures (fumes and vapours); otherwise implement suitable measures such as extraction facilities.
- Welding helmet with proper protection against ionizing radiation (IR and UV radiation) and heat.
- Dry welding clothing (shoes, gloves and body protection) to protect against warm environments with conditions comparable to ambient temperatures of 100 °C or higher and arcing and work on live components.
- Hearing protection against harming noise.

⚠ WARNING**Risk of injury due to radiation or heat!**

Arc radiation results in injury to skin and eyes.

Contact with hot workpieces and sparks results in burns.

- Use welding shield or welding helmet with the appropriate safety level (depending on the application)!
- Wear dry protective clothing (e.g. welding shield, gloves, etc.) according to the relevant regulations in the country in question!
- Protect persons not involved in the work against arc beams and the risk of glare using safety curtains!

⚠ WARNING**Explosion risk!**

Apparently harmless substances in closed containers may generate excessive pressure when heated.

- Move containers with inflammable or explosive liquids away from the working area!
- Never heat explosive liquids, dusts or gases by welding or cutting!

**Fire hazard!**

Due to the high temperatures, sparks, glowing parts and hot slag that occur during welding, there is a risk of flames.

- Be watchful of potential sources of fire in the working area!
- Do not carry any easily inflammable objects, e.g. matches or lighters.
- Ensure suitable fire extinguishers are available in the working area!
- Thoroughly remove any residue of flammable materials from the workpiece prior to starting to weld.
- Only further process workpieces after they have cooled down. Do not allow them to contact any flammable materials!

CAUTION



Smoke and gases!

Smoke and gases can lead to breathing difficulties and poisoning. In addition, solvent vapour (chlorinated hydrocarbon) may be converted into poisonous phosgene due to the ultraviolet radiation of the arc!

- Ensure that there is sufficient fresh air!
- Keep solvent vapour away from the arc beam field!
- Wear suitable breathing apparatus if appropriate!

CAUTION



Noise exposure!

Noise exceeding 70 dBA can cause permanent hearing damage!

- Wear suitable ear protection!
- Persons located within the working area must wear suitable ear protection!



Obligations of the operator!

The respective national directives and laws must be complied with when operating the machine!

- **Implementation of national legislation relating to framework directive 89/391/EEC on the introduction of measures to encourage improvements in the safety and health of workers at work and associated individual guidelines.**
- **In particular, directive 89/655/EEC concerning the minimum safety and health requirements for the use of work equipment by workers at work.**
- **The regulations applicable to occupational safety and accident prevention in the country concerned.**
- **Setting up and operating the machine as per IEC 60974.-9.**
- **Brief the user on safety-conscious work practices on a regular basis.**
- **Regularly inspect the machine as per IEC 60974.-4.**



The manufacturer's warranty becomes void if non-genuine parts are used!

- **Only use system components and options (power sources, welding torches, electrode holders, remote controls, spare parts and replacement parts, etc.) from our range of products!**
- **Only insert and lock accessory components into the relevant connection socket when the machine is switched off.**



Requirements for connection to the public mains network

High-performance machines can influence the mains quality by taking current from the mains network. For some types of machines, connection restrictions or requirements relating to the maximum possible line impedance or the necessary minimum supply capacity at the interface with the public network (Point of Common Coupling, PCC) can therefore apply. In this respect, attention is also drawn to the machines' technical data. In this case, it is the responsibility of the operator, where necessary in consultation with the mains network operator, to ensure that the machine can be connected.

⚠ CAUTION



Electromagnetic fields!

The power source may cause electrical or electromagnetic fields to be produced which could affect the correct functioning of electronic equipment such as IT or CNC devices, telecommunication lines, power cables, signal lines and pacemakers.



- Observe the maintenance instructions > see 6.3 chapter!
- Unwind welding leads completely!
- Shield devices or equipment sensitive to radiation accordingly!
- The correct functioning of pacemakers may be affected (obtain advice from a doctor if necessary).



According to IEC 60974-10, welding machines are divided into two classes of electromagnetic compatibility (the EMC class can be found in the Technical data) > see 8 chapter:



Class A machines are not intended for use in residential areas where the power supply comes from the low-voltage public mains network. When ensuring the electromagnetic compatibility of class A machines, difficulties can arise in these areas due to interference not only in the supply lines but also in the form of radiated interference.



Class B machines fulfil the EMC requirements in industrial as well as residential areas, including residential areas connected to the low-voltage public mains network.

Setting up and operating

When operating arc welding systems, in some cases, electro-magnetic interference can occur although all of the welding machines comply with the emission limits specified in the standard. The user is responsible for any interference caused by welding.

In order to **evaluate** any possible problems with electromagnetic compatibility in the surrounding area, the user must consider the following: (see also EN 60974-10 Appendix A)

- Mains, control, signal and telecommunication lines
- Radios and televisions
- Computers and other control systems
- Safety equipment
- The health of neighbouring persons, especially if they have a pacemaker or wear a hearing aid
- Calibration and measuring equipment
- The immunity to interference of other equipment in the surrounding area
- The time of day at which the welding work must be carried out

Recommendations for **reducing interference emission**

- Mains connection, e.g. additional mains filter or shielding with a metal tube
- Maintenance of the arc welding system
- Welding leads should be as short as possible and run closely together along the ground
- Potential equalization
- Earthing of the workpiece. In cases where it is not possible to earth the workpiece directly, it should be connected by means of suitable capacitors.
- Shielding from other equipment in the surrounding area or the entire welding system

2.4 Transport and installation

WARNING



Risk of injury due to improper handling of shielding gas cylinders!
Improper handling and insufficient securing of shielding gas cylinders can cause serious injuries!

- Observe the instructions from the gas manufacturer and any relevant regulations concerning the use of compressed air!
- Do not attach any element to the shielding gas cylinder valve!
- Prevent the shielding gas cylinder from heating up.

CAUTION



Risk of accidents due to supply lines!
During transport, attached supply lines (mains leads, control cables, etc.) can cause risks, e.g. by causing connected machines to tip over and injure persons!

- Disconnect all supply lines before transport!



Risk of tipping!

There is a risk of the machine tipping over and injuring persons or being damaged itself during movement and set up. Tilt resistance is guaranteed up to an angle of 10° (according to IEC 60974-1).

- Set up and transport the machine on level, solid ground.
- Secure add-on parts using suitable equipment.



The units are designed for operation in an upright position!
Operation in non-permissible positions can cause equipment damage.

- ***Only transport and operate in an upright position!***



Accessory components and the power source itself can be damaged by incorrect connection!

- ***Only insert and lock accessory components into the relevant connection socket when the machine is switched off.***
- ***Comprehensive descriptions can be found in the operating instructions for the relevant accessory components.***
- ***Accessory components are detected automatically after the power source is switched on.***



Protective dust caps protect the connection sockets and therefore the machine against dirt and damage.

- ***The protective dust cap must be fitted if there is no accessory component being operated on that connection.***
- ***The cap must be replaced if faulty or if lost!***

3 Intended use

⚠ WARNING



Hazards due to improper usage!

The machine has been constructed to the state of the art and any regulations and standards applicable for use in industry and trade. It may only be used for the welding procedures indicated at the rating plate. Hazards may arise for persons, animals and material objects if the equipment is not used correctly. No liability is accepted for any damages arising from improper usage!

- The equipment must only be used in line with its designated purpose and by trained or expert personnel!
- Do not improperly modify or convert the equipment!

Arc welding machine for gas-shielded metal-arc welding and MMA welding as secondary process. It may be possible to expand the range of functions by using accessories (see the documentation in the relevant chapter).

3.1 Documents which also apply

3.1.1 Warranty



For more information refer to the "Warranty registration" brochure supplied and our information regarding warranty, maintenance and testing at www.ewm-group.com!

3.1.2 Declaration of Conformity



The labelled machine complies with the following EC directives in terms of its design and construction:

- Low Voltage Directive (LVD)
- Electromagnetic Compatibility Directive (EMC)
- Restriction of Hazardous Substance (RoHS)

In case of unauthorised changes, improper repairs, non-compliance with specified deadlines for "Arc Welding Equipment – Inspection and Testing during Operation", and/or prohibited modifications which have not been explicitly authorised by EWM, this declaration shall be voided. An original document of the specific declaration of conformity is included with every product.

3.1.3 Welding in environments with increased electrical hazards



In compliance with IEC / DIN EN 60974, VDE 0544 the machines can be used in environments with an increased electrical hazard.

3.1.4 Service documents (spare parts and circuit diagrams)

⚠ WARNING



Do not carry out any unauthorised repairs or modifications!

To avoid injury and equipment damage, the unit must only be repaired or modified by specialist, skilled persons!

The warranty becomes null and void in the event of unauthorised interference.

- Appoint only skilled persons for repair work (trained service personnel)!

Original copies of the circuit diagrams are enclosed with the unit.

Spare parts can be obtained from the relevant authorised dealer.

3.1.5 Calibration/Validation

We hereby confirm that this machine has been tested using calibrated measuring equipment, as stipulated in IEC/EN 60974, ISO/EN 17662, EN 50504, and complies with the admissible tolerances. Recommended calibration interval: 12 months

4 Machine description – quick overview

4.1 Front view



Coolant tank and quick connect coupling of coolant supply and return are only fitted in machines with water cooling.

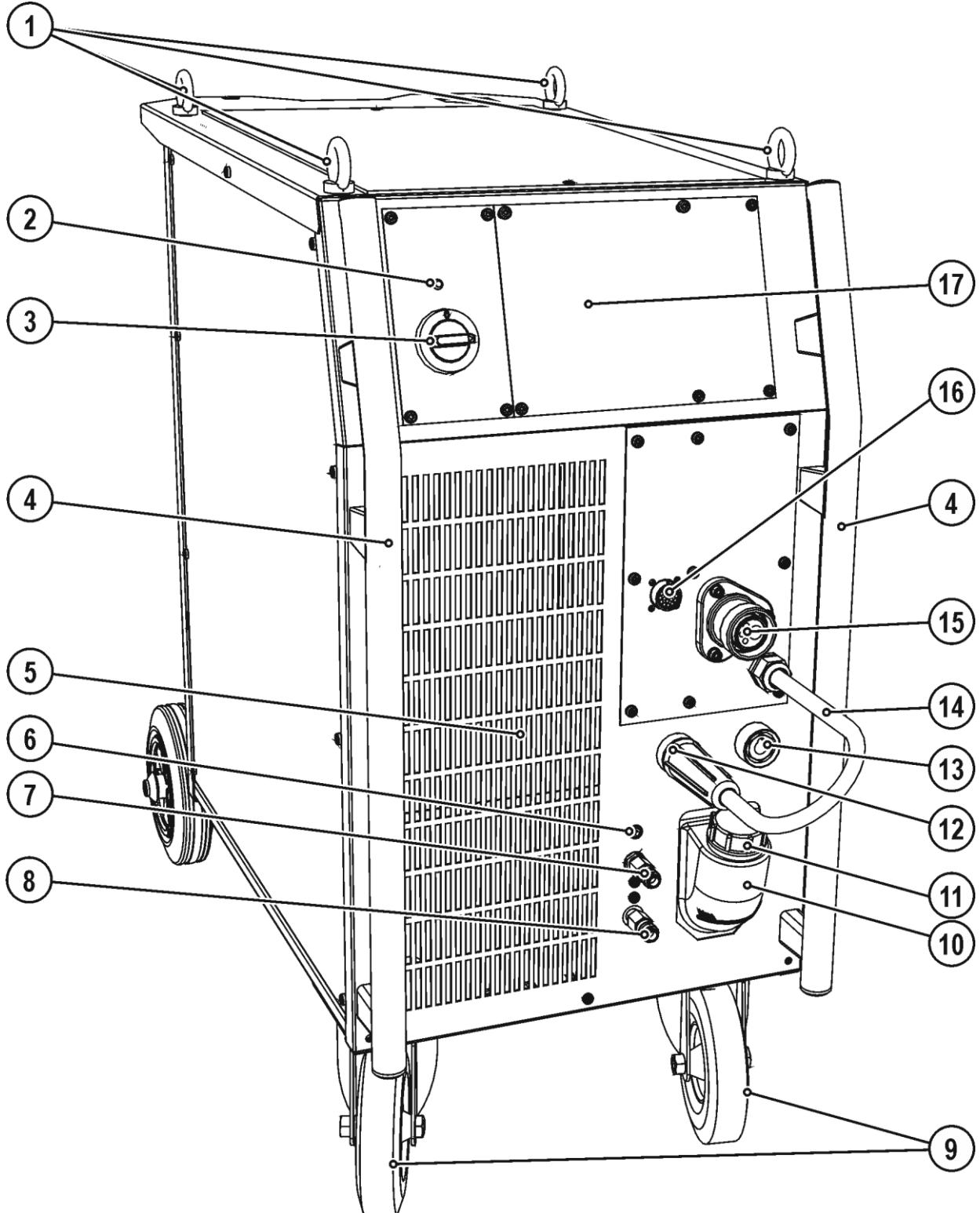









Figure 4-1

Item	Symbol	Description
1		Lifting lug
2		Ready for operation signal light Signal light on when the machine is switched on and ready for operation
3		Main switch, machine on/off
4		Carrying handle
5		Cooling air inlet
6		Automatic cut-out of coolant pump key button press to reset a triggered fuse
7		Quick connect coupling (red) coolant return
8		Quick connect coupling (blue) coolant supply
9		Wheels, guide castors
10		Coolant tank
11		Coolant tank cap
12		Connection socket, “-” welding current <ul style="list-style-type: none"> •----- MIG/MAG welding: workpiece connection •----- MIG/MAG cored wire welding: welding current connection for the welding torch •----- MMA welding: electrode holder connection
13		Connection socket, “+” welding current <ul style="list-style-type: none"> •----- MIG/MAG welding: welding current connection for the welding torch •----- MIG/MAG cored wire welding: workpiece connection •----- MMA welding: workpiece connection
14		Welding current cable, polarity selection Welding current to the central connector/torch, enables polarity selection. <ul style="list-style-type: none"> •----- MIG/MAG: Connection socket for “+” welding current •----- Self-shielding cored wire
15		Welding torch connection (Euro or Dinse torch connector) Welding current, shielding gas and torch trigger integrated
16		19-pole connection socket (analogue) For connecting analogue remote controls
17		Machine control > see 4.4 chapter

4.2 Rear view

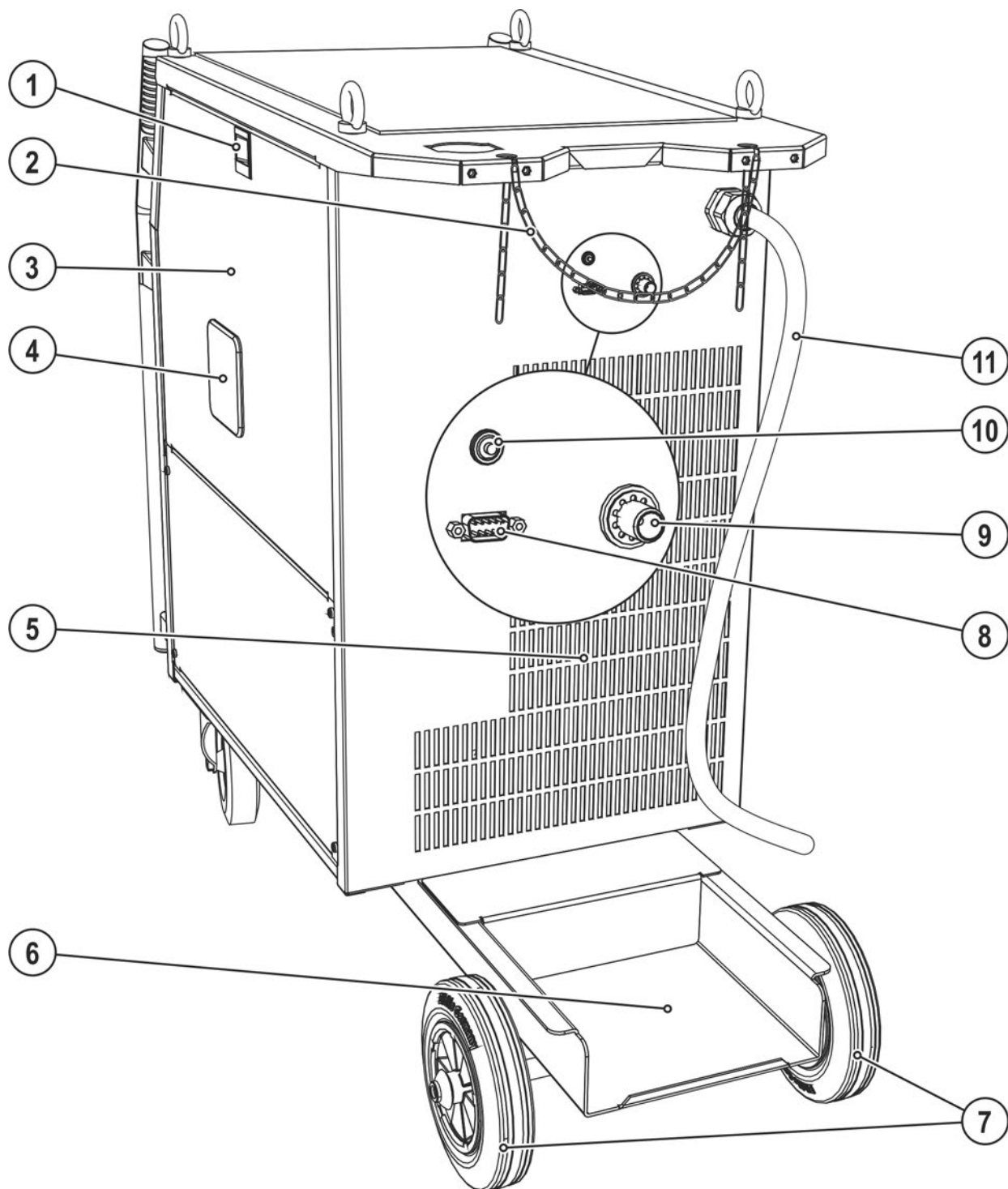

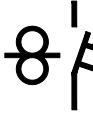

Figure 4-2

Item	Symbol	Description
1		Slide latch, lock for the protective cap
2		Securing elements for shielding gas cylinder (strap/chain)
3		Protective cap Cover for the wire feed mechanism and other operating elements. Depending on the machine series, additional stickers with information on the replacement parts and JOB lists will be located on the inside.
4		Wire spool inspection window Check wire supply
5		Cooling air outlet
6		Bracket for shielding gas cylinder
7		Wheels, fixed castors
8		D-sub connection socket, 9-pole With this machine series for maintenance purposes only (specialist staff)
9		Connecting nipple G¹/₄, shielding gas connection
10		Key button, Automatic cutout Wire feed motor supply voltage fuse (press to reset a triggered fuse)
11		Mains connection cable > see 5.1.8 chapter

4.3 Inside view

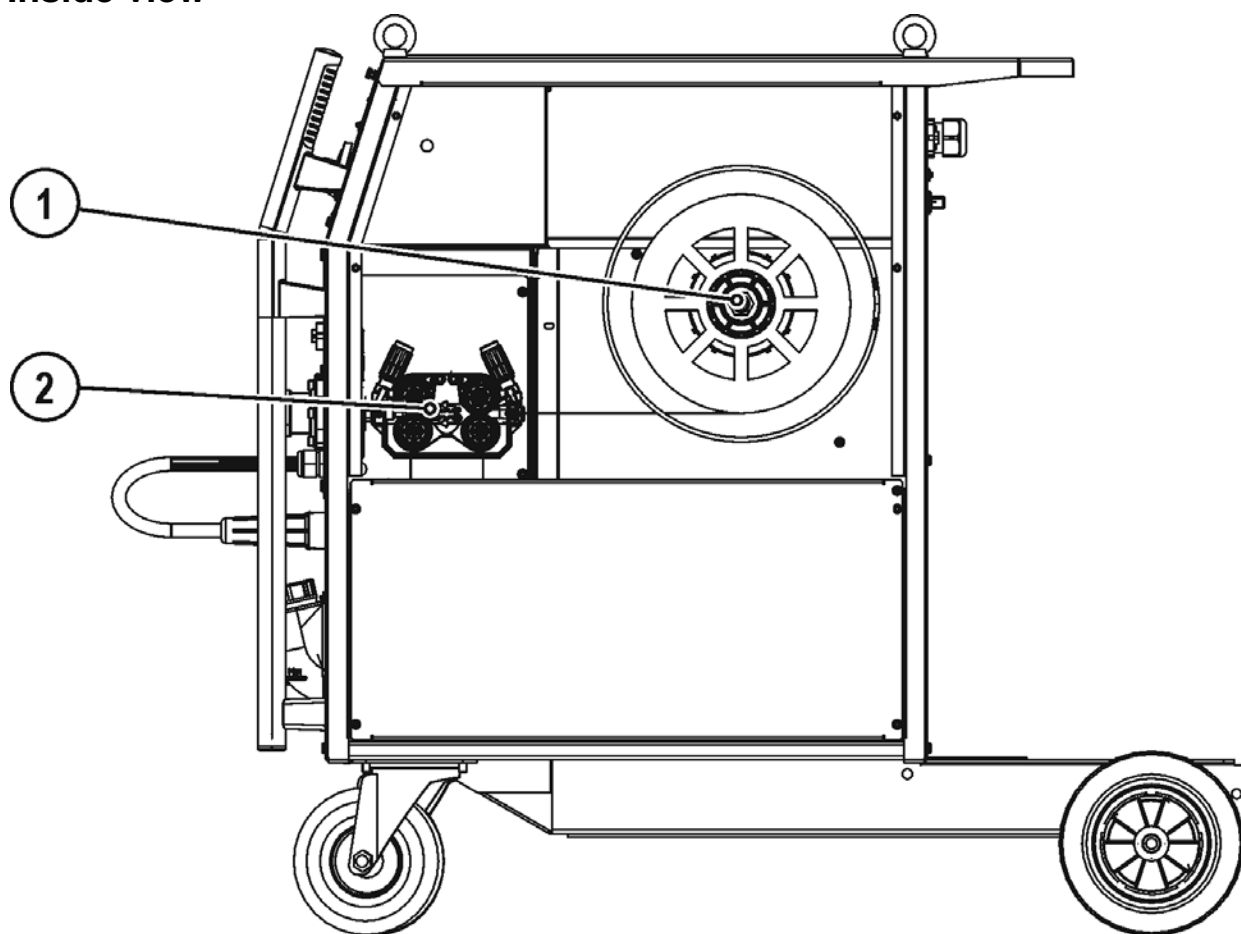

Figure 4-3

Item	Symbol	Description
1		Wire spool holder
2		Wire feed unit

4.4 Machine control – Operating elements

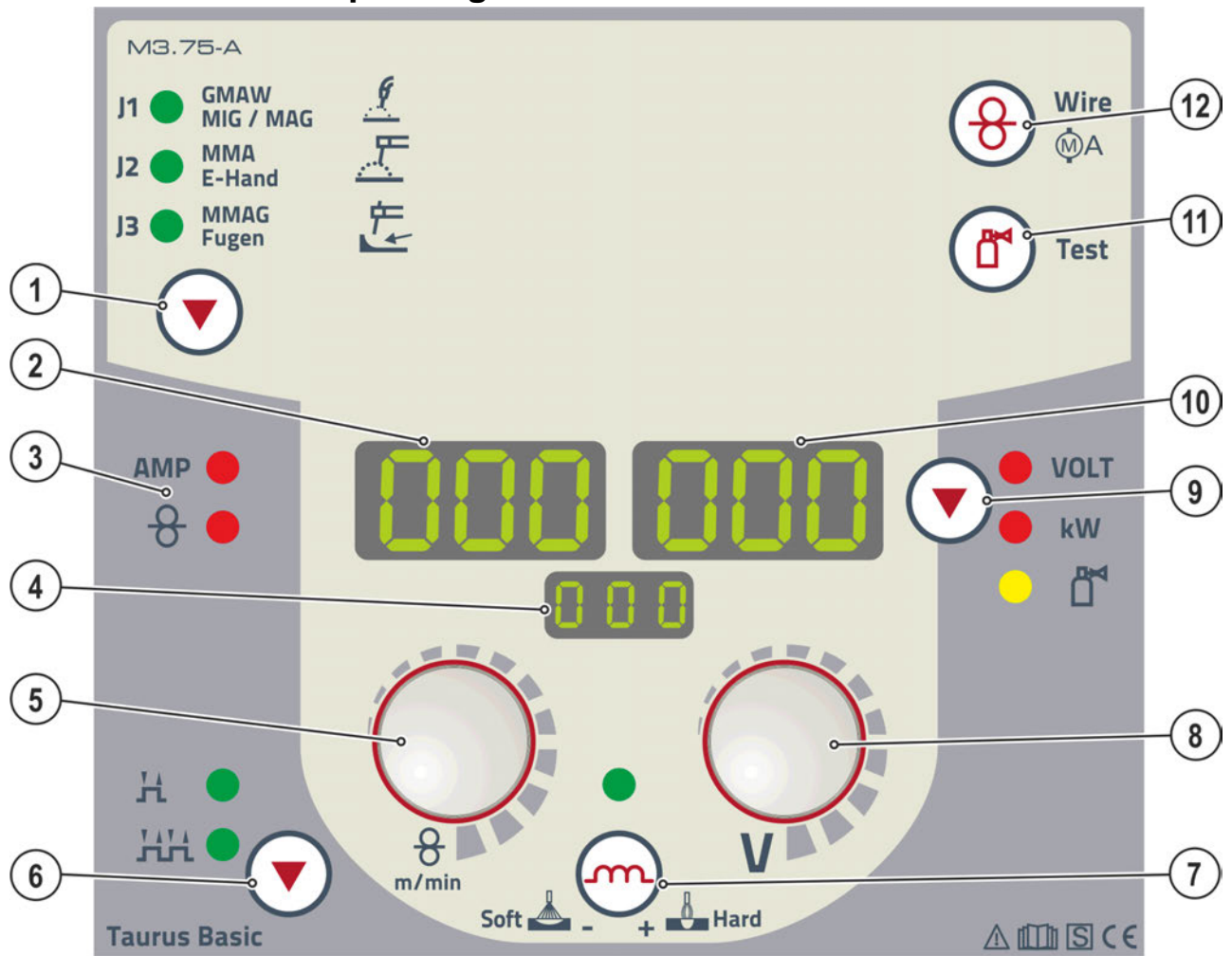











Figure 4-4

Item	Symbol	Description
1		Button, welding process J1----- MIG/MAG welding J2----- MMA welding J3----- Air arc gouging
2		Display, left Welding current, wire feed speed
3		Status displays AMP ---- "Welding current display" signal light ⊗----- "Wire feed speed display" signal light
4		Display, welding process J1----- MIG/MAG welding J2----- MMA welding J3----- Gouging
5		Welding parameter setting, rotary dial For setting the welding performance, for selecting the JOB (welding task) and for setting other welding parameters.
6		Select operating mode button H ----- Non-latched HH----- Latched

Item	Symbol	Description
7		Push-button, throttling effect (arc dynamics) +  Hard ---- Arc is harder and more narrow Soft  ---- Arc is softer and wider
8		Rotary dial, welding voltage Adjustment of the welding voltage from min. to max. (twin-knob operation: wire speed/welding voltage)
9		Push-button, parameter selection right/power-saving mode VOLT --- Welding voltage kW----- Welding power display  ----- Gas flow rate (option) Enter power-saving mode by pressing the push-button for long interval.
10		Display, right Welding voltage, welding performance, motor current (wire feed mechanism) during wire inching, shielding gas flow rate (option)
11		Push-button gas test / rinse hose package > see 5.1.9.4 chapter
12		Push-button, wire inching Potential- and gas-free inching of the wire electrode through the hose package to the welding torch > see 5.3.2.4 chapter.

5 Design and function

⚠ WARNING



Risk of injury from electric shock!

Contact with live parts, e.g. welding current sockets, is potentially fatal!

- Follow safety instructions on the opening pages of the operating instructions.
- Commissioning may only be carried out by persons who have the relevant expertise of working with arc welding machines!
- Connection and welding leads (e.g. electrode holder, welding torch, workpiece lead, interfaces) may only be connected when the machine is switched off!

5.1 Transport and installation

5.1.1 Lifting by crane

⚠ WARNING



Risk of injury during lifting by crane!

When lifting the machine by crane, persons may be severely injured by falling machines or mount-on components.

- Simultaneous lifting of system components such as power source, wire feeder or cooling unit without suitable crane components is not allowed. Each system component has to be lifted separately!
- Remove any supply leads and accessories before lifting by crane (e.g. hose package, wire spool, shielding gas cylinder, toolbox, wire feeder, remote control, etc.!)!
- Properly close and lock all casing covers and protective caps before lifting by crane!
- Use the correct number of hoisting equipment of the right size in the correct position! Observe craning principle (see figure)!
- For machines with lifting eyes: always lift all lifting eyes simultaneously!
- When using retrofitted craning frames etc.: always use at least two lifting points positioned as far apart as possible – observe option description.
- Avoid any jerky movements!
- Ensure that the load is distributed evenly! • Use chain hoists and chain slings of the same length only!
- Stay outside the danger zone underneath the machine!
- Observe the regulations regarding occupational safety and accident prevention for the respective country.

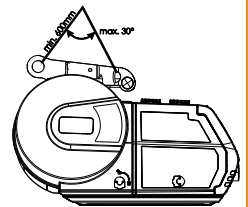
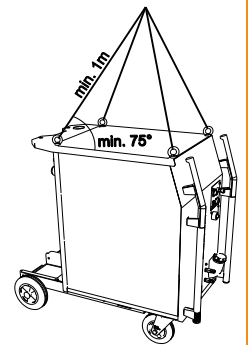

Craning principle



Risk of injury due to unsuitable lifting eye!

In case of improper use of lifting eyes or the use of unsuitable lifting eyes, persons can be seriously damaged by falling equipment or add-on components!

- The lifting eye must be completely screwed in!
- The lifting eye must be positioned flat onto and in full contact with the supporting surfaces!
- Check that the lifting eyes are securely fastened before use and check for any damage (corrosion, deformation)!
- Do not use or screw in damaged lifting eyes!
- Avoid lateral loading of the lifting eyes!

5.1.2 Ambient conditions



The machine must not be operated in the open air and must only be set up and operated on a suitable, stable and level base!

- *The operator must ensure that the ground is non-slip and level, and provide sufficient lighting for the place of work.*
- *Safe operation of the machine must be guaranteed at all times.*



Unusually high quantities of dust, acid, corrosive gases or substances may damage the equipment.

- *Avoid high volumes of smoke, vapour, oil vapour and grinding dust!*
- *Avoid ambient air containing salt (sea air)!*

5.1.2.1 In operation

Temperature range of the ambient air:

- -25 °C to +40 °C

Relative air humidity:

- Up to 50% at 40 °C
- Up to 90% at 20 °C

5.1.2.2 Transport and storage

Storage in an enclosed space, temperature range of the ambient air:

- -30 °C to +70 °C

Relative air humidity

- Up to 90% at 20 °C

5.1.3 Machine cooling



Insufficient ventilation results in a reduction in performance and equipment damage.

- *Observe the ambient conditions!*
- *Keep the cooling air inlet and outlet clear!*
- *Observe the minimum distance of 0.5 m from obstacles!*

5.1.4 Workpiece lead, general

CAUTION



Risk of burning due to incorrect welding current connection!

If the welding current plugs (machine connections) are not locked or if the workpiece connection is contaminated (paint, corrosion), these connections and leads can heat up and cause burns when touched!

- Check welding current connections on a daily basis and lock by turning to the right when necessary.
- Clean workpiece connection thoroughly and secure properly. Do not use structural parts of the workpiece as welding current return lead!

5.1.5 Welding torch cooling system



Insufficient frost protection in the welding torch coolant!

Depending on the ambient conditions, different liquids are used for cooling the welding torch > see 5.1.5.1 chapter.

Coolants with frost protection (KF 37E or KF 23E) must be checked regularly to ensure that the frost protection is adequate to prevent damage to the machine or the accessory components.

- The coolant must be checked for adequate frost protection with the TYP 1 frost protection tester .
- Replace coolant as necessary if frost protection is inadequate!



Coolant mixtures!

Mixtures with other liquids or the use of unsuitable coolants result in material damage and renders the manufacturer's warranty void!

- Only use the coolant described in this manual (overview of coolants).
- Do not mix different coolants.
- When changing the coolant, the entire volume of liquid must be changed.



Dispose of the coolant in accordance with local regulations and the material safety data sheets (German waste code number: 70104).

May not be disposed of in household waste.

Prevent entry into sewers.

Absorb with liquid-binding material (sand, gravel, acid-binding agents, universal binding agents, sawdust).

5.1.5.1 Approved coolants overview

Coolant	Temperature range
KF 23E (Standard)	-10 °C to +40 °C
KF 37E	-20 °C to +10 °C

5.1.5.2 Maximal hose package length

	Pump 3.5 bar	Pump 4.5 bar
Machines with or without separate wire feeder	30 m	60 m
Compact machines with additional intermediate drive (example. miniDrive)	20 m	30 m
Machines with separate wire feeder and additional intermediate drive (example: miniDrive)	20 m	60 m

Data as a rule refer to the entire hose package length

including welding torch. The pump output is shown on the type plate (parameter: Pmax).

Pump 3.5 bar: Pmax = 0.35 MPa (3.5 bar)

Pump 4.5 bar: Pmax = 0.45 MPa (4.5 bar)

5.1.5.3 Adding coolant

The unit is supplied ex works with a minimum level of coolant.

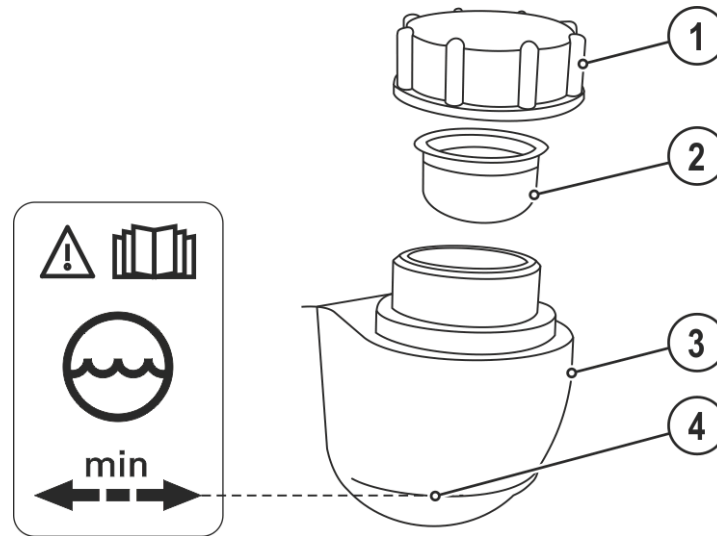

Figure 5-1

Item	Symbol	Description
1		Coolant tank cap
2		Coolant filter sieve
3		Coolant tank
4		"Min" mark Minimum coolant level

- Unscrew and remove the coolant tank sealing cover.
- Check filter sieve insert for dirt, clean if necessary and reinsert into position.
- Top up coolant to the filter sieve insert, close sealing cover again.



After the initial filling, wait for at least one minute when the machine is switched on so that the hose package is filled with coolant completely and without bubbles.

With frequent changes of torch and during the initial filling process, the cooling unit tank should be topped up as necessary.



The level of coolant must never fall below the "min" mark.



If there is less coolant in the coolant tank than the minimum required you may need to vent the coolant circuit. In this case the welding machine will automatically shut down the coolant pump and signal an error, > see 7 chapter.

5.1.6 Notes on the installation of welding current leads

- Incorrectly installed welding current leads can cause faults in the arc (flickering).**
- Lay the workpiece lead and hose package of power sources without HF igniter (MIG/MAG) for as long and as close as possible in parallel.**
- Lay the workpiece lead and hose package of power sources with HF igniter (TIG) for as long as possible in parallel with a distance of 20 cm to avoid HF sparkover.**
- Always keep a distance of at least 20 cm to leads of other power sources to avoid interferences**
- Always keep leads as short as possible! For optimum welding results max. 30 m (welding lead + intermediate hose package + torch lead).**

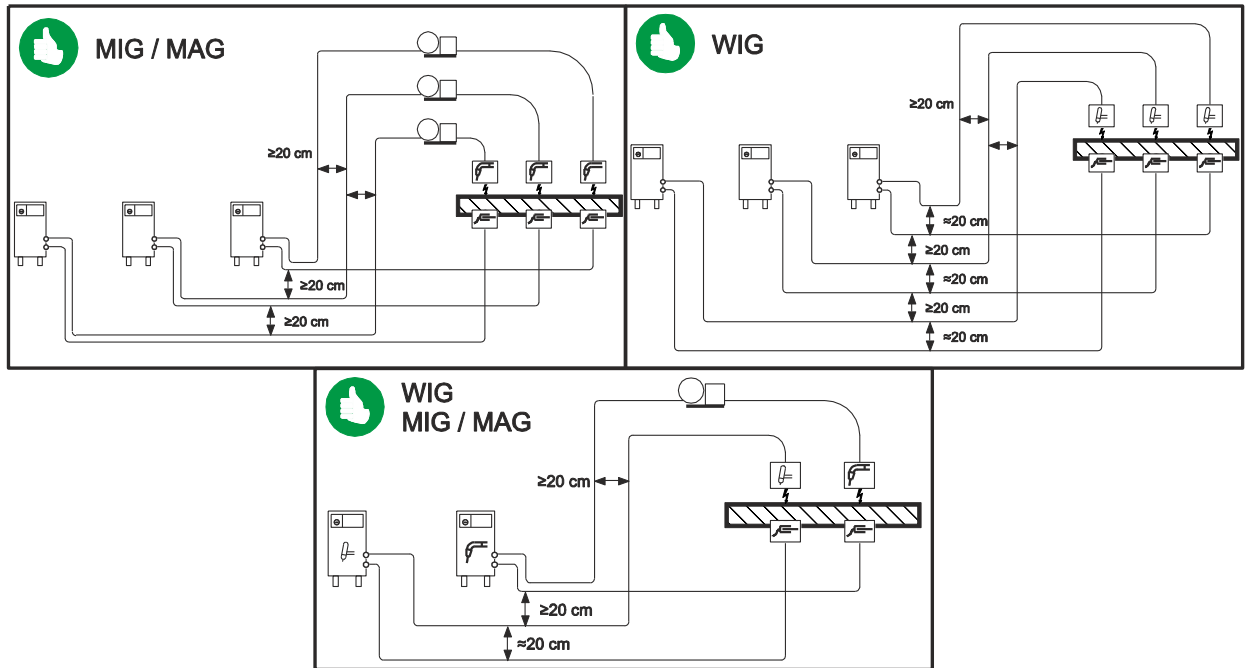

Figure 5-2

- Use an individual welding lead to the workpiece for each welding machine!**

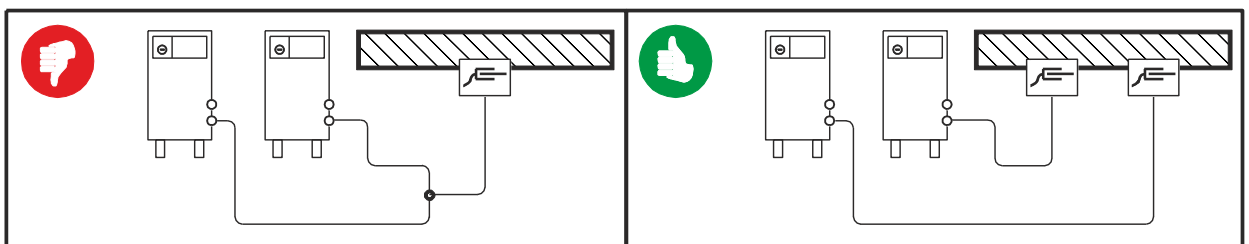

Figure 5-3

- Fully unroll welding current leads, torch hose packages and intermediate hose packages. Avoid loops!**
- Always keep leads as short as possible!**
- Lay any excess cable lengths in meanders.**

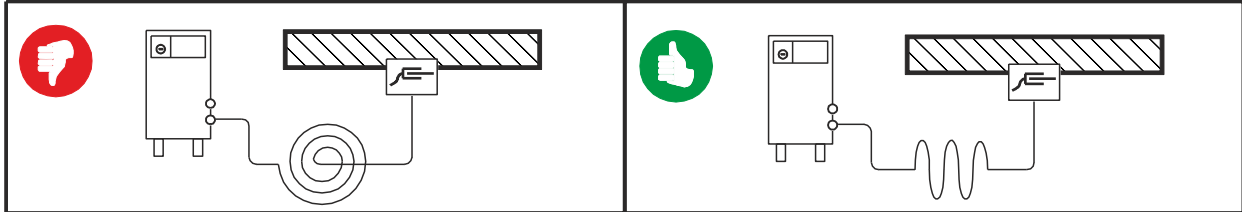

Figure 5-4

5.1.7 Stray welding currents

WARNING



Risk of injury due to stray welding currents!

Stray welding currents can destroy protective earth conductors, damage machines and electronic devices and cause overheating of components, leading to fire.

- Check that all welding current connections are firmly secured and electrical connections are in perfect condition.
- Set up, attach or suspend all conductive power source components such as casing, transport vehicles and crane frames so they are insulated.
- Do not place any other electronic devices such as drills or angle grinders on the power source, transport vehicle or crane frames unless they are insulated.
- Always put welding torches and electrode holders on an insulated surface when they are not in use.

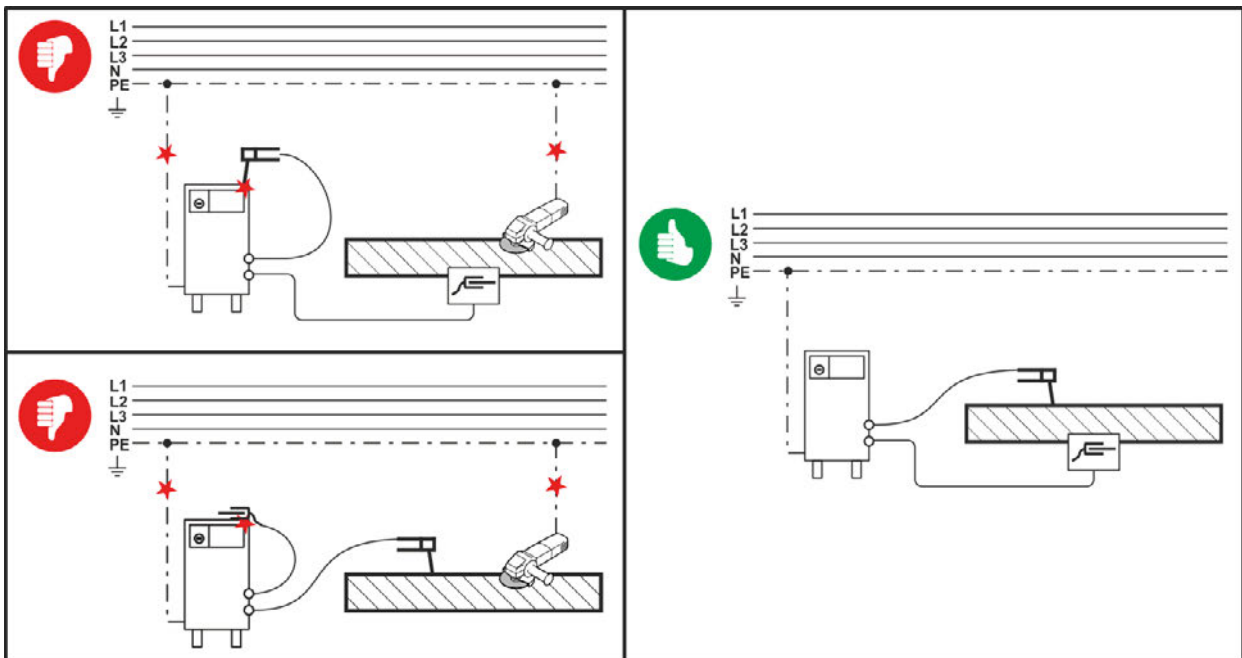

Figure 5-5

5.1.8 Mains connection

⚠ DANGER**Hazards caused by improper mains connection!****An improper mains connection can cause injuries or damage property!**

- Only operate machine using a socket that has correctly fitted protective earth.
- The mains voltage indicated on the rating plate must match the supply voltage.
- If a new mains plug must be fitted, only an electrician may do so as per the relevant national legislation or regulations.
- Mains plug, socket and lead must be checked by an electrician on a regular basis.
- When operating the generator, always ensure it is earthed as stipulated in the operating instructions. The network created must be suitable for operating machines according to protection class I.

5.1.8.1 Mains configuration

**The machine may be connected to:**

- a three-phase system with four conductors and an earthed neutral conductor
- a three-phase system with three conductors of which any one can be earthed, e.g. the outer conductor

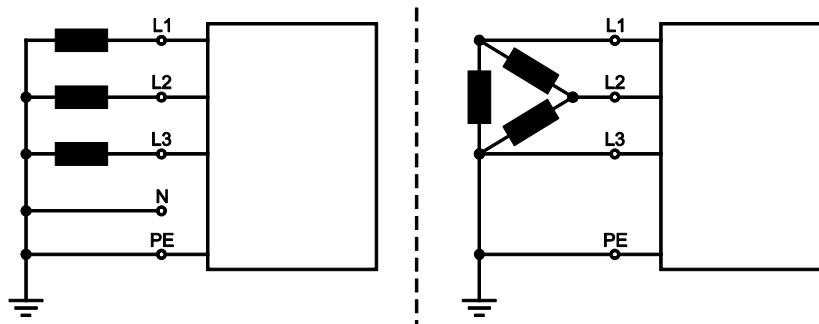

Figure 5-6

Legend

Item	Designation	Colour code
L1	Outer conductor 1	brown
L2	Outer conductor 2	black
L3	Outer conductor 3	grey
N	Neutral conductor	blue
PE	Protective conductor	green-yellow

- Insert mains plug of the switched-off machine into the appropriate socket.

5.1.9 Shielding gas supply (shielding gas cylinder for welding machine)

⚠ WARNING

Risk of injury due to improper handling of shielding gas cylinders! Improper handling and insufficient securing of shielding gas cylinders can cause serious injuries!

- Place shielding gas cylinder into the designated holder and secure with fastening elements (chain/belt)!
- Attach the fastening elements within the upper half of the shielding gas cylinder!
- The fastening elements must tightly enclose the shielding gas cylinder!



An unhindered shielding gas supply from the shielding gas cylinder to the welding torch is a fundamental requirement for optimum welding results. In addition, a blocked shielding gas supply may result in the welding torch being destroyed.

- **Always re-fit the yellow protective cap when not using the shielding gas connection.**
- **All shielding gas connections must be gas tight.**

5.1.9.1 Pressure regulator connection

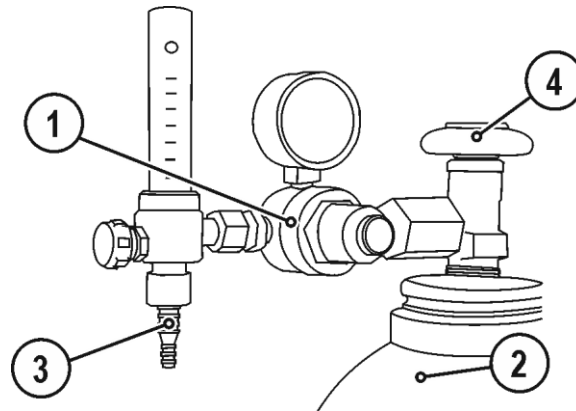

Figure 5-7

Item	Symbol	Description
1		Pressure regulator
2		Shielding gas cylinder
3		Output side of the pressure regulator
4		Cylinder valve

- Before connecting the pressure regulator to the gas cylinder, open the cylinder valve briefly to blow out any dirt.
- Tighten the pressure regulator screw connection on the gas bottle valve to be gas-tight.
- Screw gas hose connection crown nut onto the output side of the pressure regulator.

5.1.9.2 Shielding gas hose connection

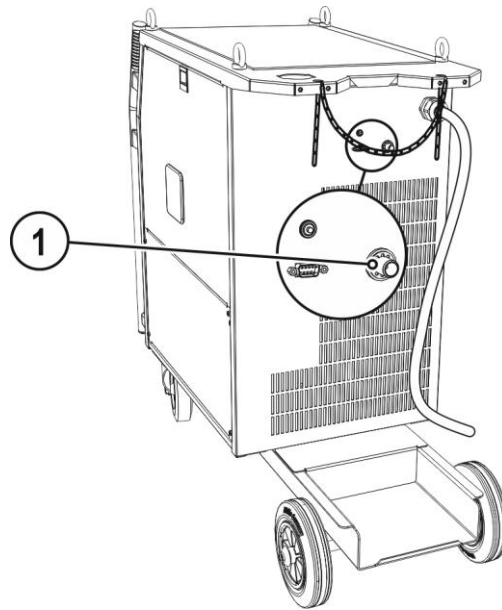

Figure 5-8

Item	Symbol	Description
1		Connecting nipple G $\frac{1}{4}$ ", shielding gas connection

- Connect crown nut of the shielding gas line to the G $\frac{1}{4}$ " connecting nipple.

5.1.9.3 Gas test – setting the shielding gas volume

- Slowly open the gas cylinder valve.
- Open the pressure regulator.
- Switch on the power source at the main switch.
- Set the relevant gas quantity for the application on the pressure regulator.
- You can activate the gas test on the machine control (see Control operating instructions) or by pressing the "Gas test/rinse hose package" push-button briefly (welding voltage and wire feed motor remain switched off – no unintentional ignition of the arc). Some welding systems have several push-buttons to set the shielding gas. The push-button is generally found near a wire feeder.

Shielding gas flows for around 25 seconds or until the button is pressed again.

If the shielding gas setting is too low or too high, this can introduce air to the weld pool and may cause pores to form. Adjust the shielding gas quantity to suit the welding task!

Setting instructions

Welding process	Recommended shielding gas quantity
MAG welding	Wire diameter x 11.5 = l/min
MIG brazing	Wire diameter x 11.5 = l/min
MIG welding (aluminium)	Wire diameter x 13.5 = l/min (100 % argon)
TIG	Gas nozzle diameter in mm corresponds to l/min gas throughput

Helium-rich gas mixtures require a higher gas volume!

The table below can be used to correct the gas volume calculated where necessary:

Shielding gas	Factor
75% Ar/25% He	1.14
50% Ar/50% He	1.35
25% Ar/75% He	1.75
100% He	3.16

5.1.9.4 Rinse hose package function

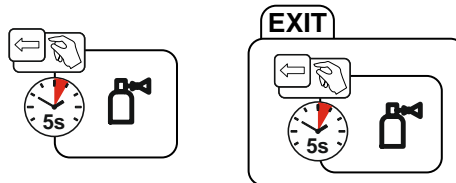

Figure 5-9

5.2 Welding data display

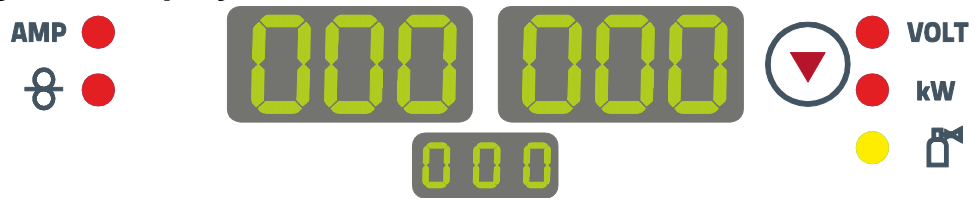

Figure 5-10

The machine control displays show all welding parameters that are required by the welder. The lower centre display shows the selected welding task (JOB number). The "parameter selection" (▼) push-button can be used to switch the display between welding voltage, welding performance and gas flow rate (option).

What is shown on the displays depends, among other things, on the selected welding procedure and the machine state (welding, power-saving mode, machine error).

MIG/MAG welding

Parameter	Nominal values	Actual values	Hold values
Welding current	<input type="checkbox"/>	<input checked="" type="checkbox"/>	<input checked="" type="checkbox"/>
Wire feed speed	<input checked="" type="checkbox"/>	<input type="checkbox"/>	<input type="checkbox"/>
Welding voltage	<input checked="" type="checkbox"/>	<input checked="" type="checkbox"/>	<input checked="" type="checkbox"/>
Welding performance	<input type="checkbox"/>	<input checked="" type="checkbox"/>	<input checked="" type="checkbox"/>

MMA welding

Parameter	Nominal values	Actual values	Hold values
Welding current	<input checked="" type="checkbox"/>	<input checked="" type="checkbox"/>	<input type="checkbox"/>
Welding voltage	<input checked="" type="checkbox"/>	<input checked="" type="checkbox"/>	<input type="checkbox"/>
Welding performance	<input type="checkbox"/>	<input checked="" type="checkbox"/>	<input type="checkbox"/>

5.3 MIG/MAG welding

5.3.1 Welding torch and workpiece line connection



Equipment damage due to improperly connected coolant pipes!

If the coolant pipes are not properly connected or a gas-cooled welding torch is used, the coolant circuit is interrupted and equipment damage can occur.

- **Connect all coolant pipes correctly!**
- **Completely unroll the hose package and the torch hose package!**
- **Observe maximal hose package length > see 5.1.5.2 chapter.**
- **When using a gas-cooled welding torch, use a hose bridge to establish the coolant circuit > see 9 chapter.**



On delivery, the Euro torch connector is fitted with a capillary tube for welding torches with a steel liner. Conversion is necessary if a welding torch with a liner is used!

- **Operate welding torches with a liner > with a guide tube.**
- **Operate welding torches with a steel liner > with a capillary tube.**

Depending on the wire electrode diameter or type, either a steel liner or liner with the correct inner diameter must be inserted in the torch!

Recommendation:

- Use a steel liner when welding hard, unalloyed wire electrodes (steel).
- Use a chrome nickel liner when welding hard, high-alloy wire electrodes (CrNi).
- Use a liner to weld or braze soft wire electrodes, high-alloy wire electrodes or aluminium materials.

Preparation for connecting welding torches with a liner:

- Push forward the capillary tube on the wire feed side in the direction of the Euro torch connector and remove it there.
- Insert the liner guide tube from the Euro torch connector side.
- Carefully insert the welding torch connector with as yet too long a liner into the Euro torch connector and secure with a crown nut.
- Cut off the liner with a liner cutter > see 9 chapter just before the wire feed roller.
- Loosen the welding torch connector and remove.
- Carefully chamfer the cut off end of the liner with a liner sharpener > see 9 chapter and sharpen.

 Some wire electrodes (e.g. self-shielding cored wire) are welded using negative polarity. In this case, the welding current lead should be connected to the "-" welding current socket, and the workpiece lead should be connected to the "+" welding current socket. Observe the information from the electrode manufacturer!

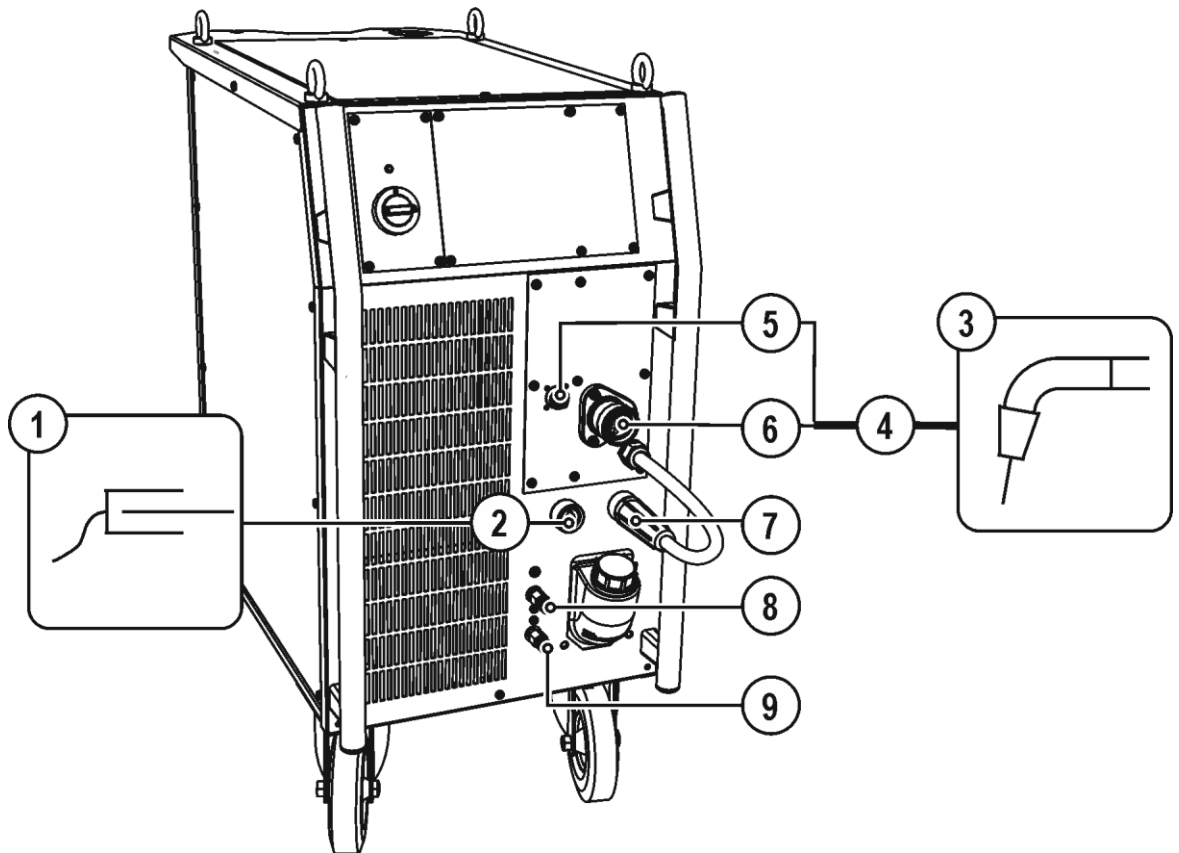







Figure 5-11

Item	Symbol	Description
1		Workpiece
2		"-" welding current connection socket •----- MIG/MAG welding: Workpiece connection
3		Welding torch
4		Welding torch hose package
5		19-pole connection socket (analogue) For connecting analogue accessory components (remote control, welding torch control lead, etc.)
6		Welding torch connection (Euro or Dinse torch connector) Welding current, shielding gas and torch trigger integrated
7		Welding current cable, polarity selection Welding current to central connection/torch. Permits polarity selection for MIG/MAG welding. •----- Standard applications > Connection for "+" welding current connection socket
8		Quick connect coupling (red) coolant return
9		Quick connect coupling (blue) coolant supply

- Insert the central plug for the welding torch into the central connector and screw together with crown nut.
- Insert the plug on the workpiece lead into the "-" welding current connection socket and lock.
- Welding current lead, insert polarity selection into the "+" welding current connection socket and lock.
- Insert the welding torch control cable into the 19-pole connection socket and lock (MIG/MAG torches with additional control cables only).

Where applicable:

- Lock connecting nipples of the cooling water tubes into the corresponding quick connect couplings:
Return line red to quick connect coupling, red (coolant return) and
supply line blue to quick connect coupling, blue (coolant supply).

5.3.2 Wire feed

CAUTION



Risk of injury due to moving parts!

The wire feeders are equipped with moving parts, which can trap hands, hair, clothing or tools and thus injure persons!

- Do not reach into rotating or moving parts or drive components!
- Keep casing covers or protective caps closed during operation!



Risk of injury due to welding wire escaping in an unpredictable manner!

Welding wire can be conveyed at very high speeds and, if conveyed incorrectly, may escape in an uncontrolled manner and injure persons!

- Before mains connection, set up the complete wire guide system from the wire spool to the welding torch!
- Check wire guide at regular intervals!
- Keep all casing covers or protective caps closed during operation!

5.3.2.1 Open the protective flap of the wire feeder



To perform the following steps, the protective flap of the wire feeder needs to be opened. Make sure to close the protective flap again before starting to work.

- Unlock and open protective flap.

5.3.2.2 Inserting the wire spool

⚠ CAUTION



Risk of injury due to incorrectly secured wire spool.

If the wire spool is not secured properly, it may come loose from the wire spool support and fall to the ground, causing damage to the machine and injuries.

- Make sure to correctly fasten the wire spool to the wire spool support.
- Before you start working, always check the wire spool is securely fastened.



Standard D300 wire spool holder can be used. Adapters > see 9 chapter are required when using standardised basket coils (DIN 8559).

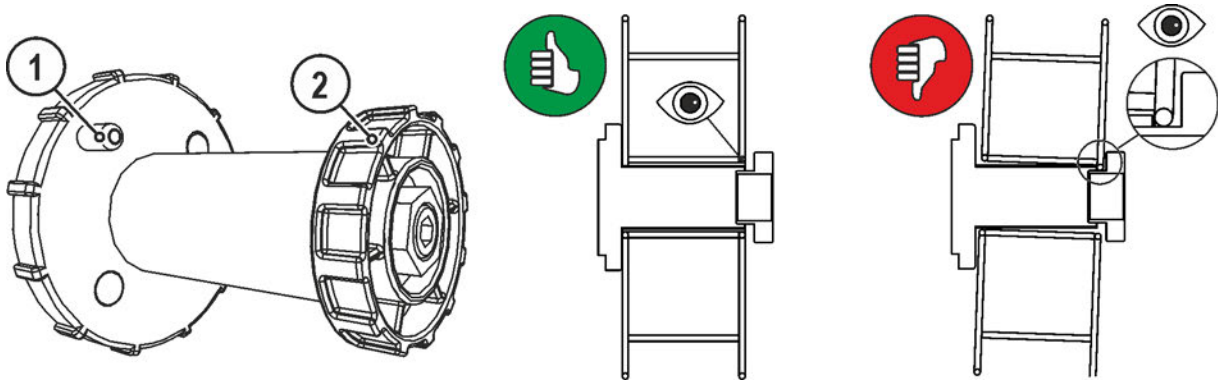

Figure 5-12

Item	Symbol	Description
1		Carrier pin For fixing the wire spool
2		Knurled nut For fixing the wire spool

- Loosen knurled nut from spool holder.
- Fix welding wire reel onto the spool holder so that the carrier pin locks into the spool bore.
- Fasten wire spool using knurled nut.

5.3.2.3 Changing the wire feed rollers

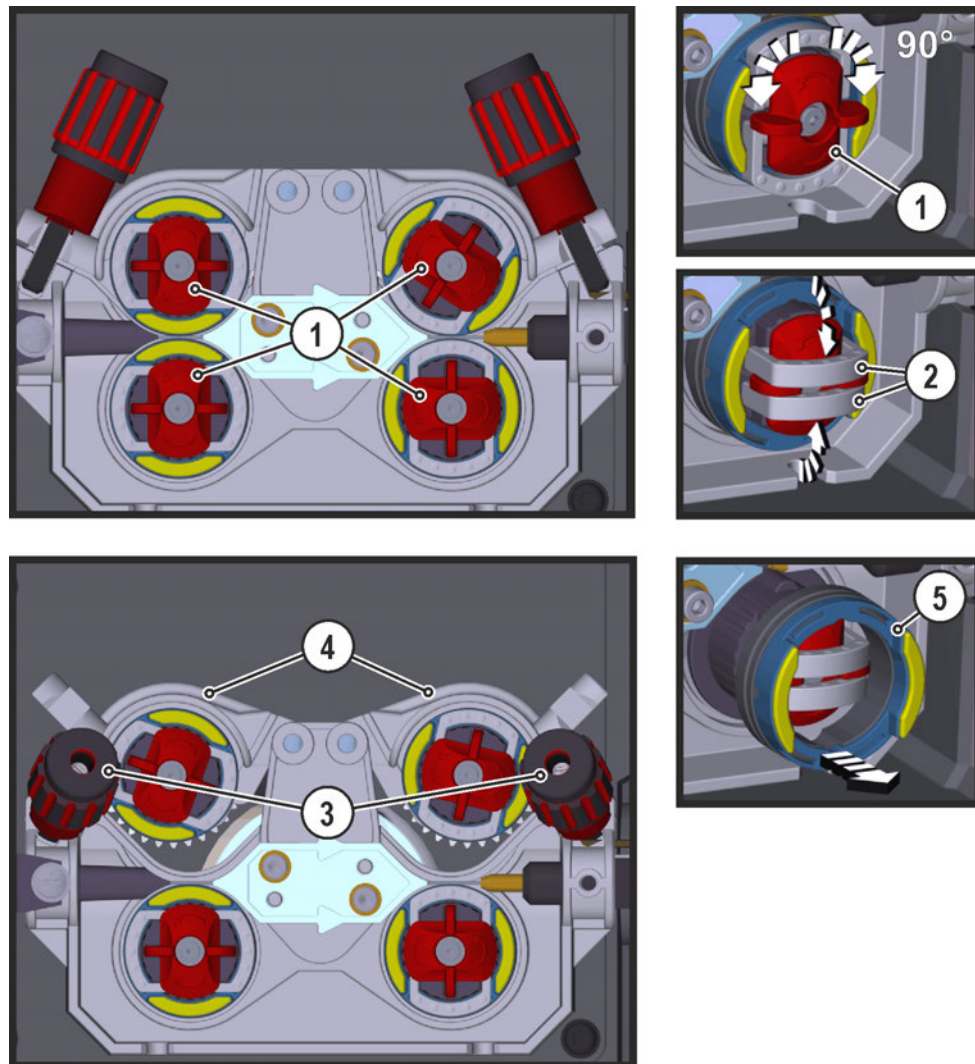

Figure 5-13

Item	Symbol	Description
1		Tommy The tommy is used to secure the closure brackets of the wire feed rollers.
2		Closure bracket The closure brackets are used to secure the wire feed rollers.
3		Feed roll tensioner Fixing the clamping unit and setting the pressure.
4		Clamping unit
5		Wire feed roller see the Wire feed roller overview table

- Rotate the tommy by 90° clockwise or anti-clockwise (tommy locks into place).
- Fold the closure brackets outwards by 90°.
- Unfasten pressure units and fold out (clamping units and pressure rollers will automatically flip upwards).
- Remove the wire feed rollers from the roller support.
- Select new wire feed rollers according to the Wire feed roller overview table and reassemble the wire feed mechanism in reverse order.

Unsatisfactory welding results due to faulty wire feeding!

The wire feed rolls must be suitable for the diameter of the wire and the material. The wire feed rolls are colour-coded to facilitate distinction (see the Wire feed roll overview table). When working with a wire diameter of > 1.6 mm the drive has to be converted for the wire feed kit ON WF 2,0-3,2MM EFEEED > see 10 chapter.

Wire feed roller overview table

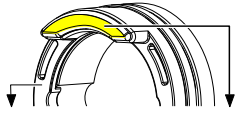
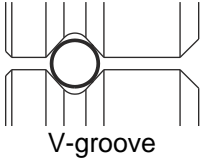
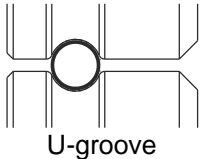
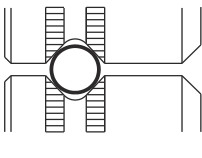
Material	Diameter		Colour code		Groove form
	Ø mm	Ø inch			
Steel Stainless steel Brazing	0.6	.023	monochrome	-	 V-groove
	0.8	.030			
	0.9/1.0	.035/.040			
	1.2	.045			
	1.4	.052			
	1.6	.060			
	2.0	.080			
	2.4	.095			
	2.8	.110			
	3.2	.125			
Aluminium	0.8	.030	bichrome	yellow	 U-groove
	0.9/1.0	.035/.040			
	1.2	.045			
	1.6	.060			
	2.0	.080			
	2.4	.095			
	2.8	.110			
	3.2	.125			
Flux cored wire	0.8	.030	bichrome	orange	 V-groove, knurled
	0.9	.035			
	1.0	.040			
	1.2	.045			
	1.4	.052			
	1.6	.060			
	2.0	.080			
	2.4	.095			

5.3.2.4 Inching the wire electrode

⚠ CAUTION



Risk of injury due to welding wire escaping from the welding torch!

The welding wire can escape from the welding torch at high speed and cause bodily injury including injuries to the face and eyes!

- Never direct the welding torch towards your own body or towards other persons!



Incorrect contact pressure will cause extensive wear of the wire feed rollers!

- With the adjusting nuts of the pressure units set the contact pressure so that the wire electrode is conveyed but will still slip through if the wire spool jams.
- Set the contact pressure of the front rollers (in wire feed direction) to a higher value!



The inching speed is infinitely adjustable by simultaneously pressing the wire inching push-button and turning the wire speed rotary knob. The left display shows the wire feed speed selected, the right display shows the current motor current of the wire feed mechanism.

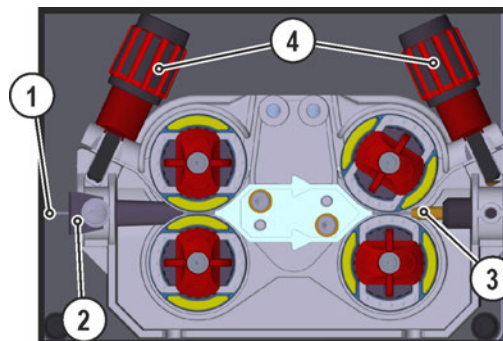

Figure 5-14

Item	Symbol	Description
1		Welding wire
2		Wire feed nipple
3		Guide tube
4		Adjusting nut

- Extend and lay out the torch hose package.
- Carefully unwind the welding wire from the wire spool and insert through the wire feed nipples up to the wire feed rollers.
- Press the inching push-button (the drive catches the welding wire and automatically guides it to the welding torch outlet).

👉 A prerequisite for the automatic inching process is the correct preparation of the wire guide, especially in the capillary and wire guide tube area > see 5.3.1 chapter.

- The contact pressure has to be adjusted separately for each side (wire inlet/outlet) at the feed roll tensioner setting nuts depending on the welding consumable used. A table with the setting values can be found on a sticker near the wire drive.

Version 1: left hand mounting

Version 2: right hand mounting

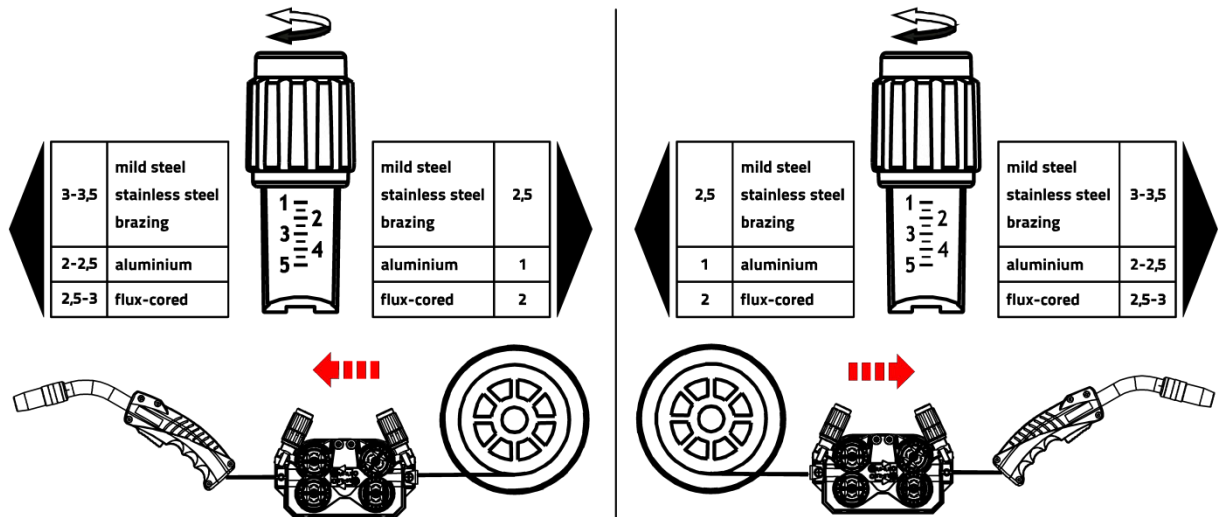

Figure 5-15

Automatic inching stop

Touch the welding torch against the workpiece during inching. Inching of the welding wire will stop as soon it touches the workpiece.

5.3.2.5 Spool brake setting

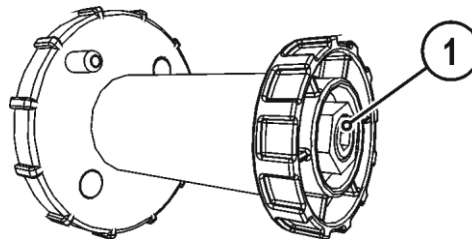

Figure 5-16

Item	Symbol	Description
1		Allen screw Securing the wire spool retainer and adjustment of the spool brake

- Tighten the Allen screw (8 mm) in the clockwise direction to increase the braking effect.

👉 Tighten the spool brake until the wire spool no longer turns when the wire feed motor stops but without it jamming during operation!

5.3.3 Welding task selection

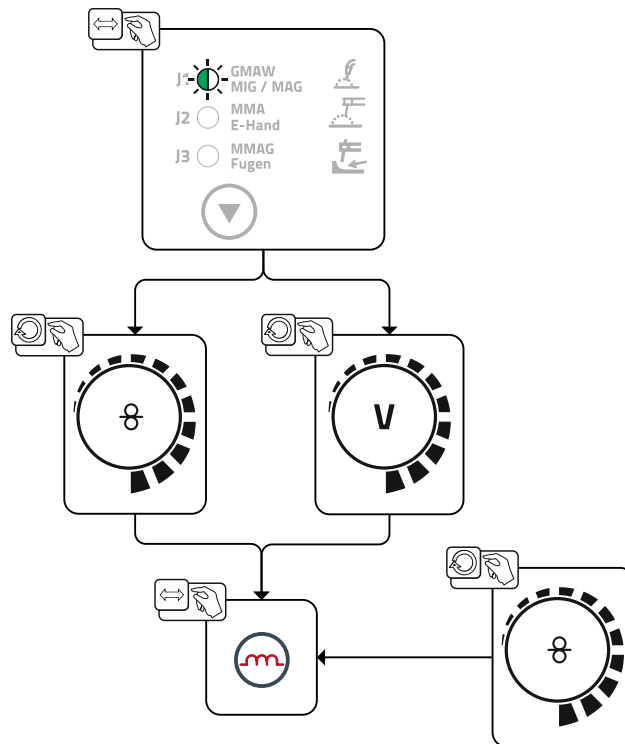

Figure 5-17

5.3.3.1 Accessory components for operating point setting

The operating point setting can also be made with the accessory components

- R11 / RG11 remote control
- Up/Down torch with two rockers (2 U/D)

You will find an overview of accessory components in the "Accessories" chapter. See the operating instructions for the machine in question for a more detailed description of the individual machines and their functions.

> see 9 chapter

5.3.4 Further welding parameters

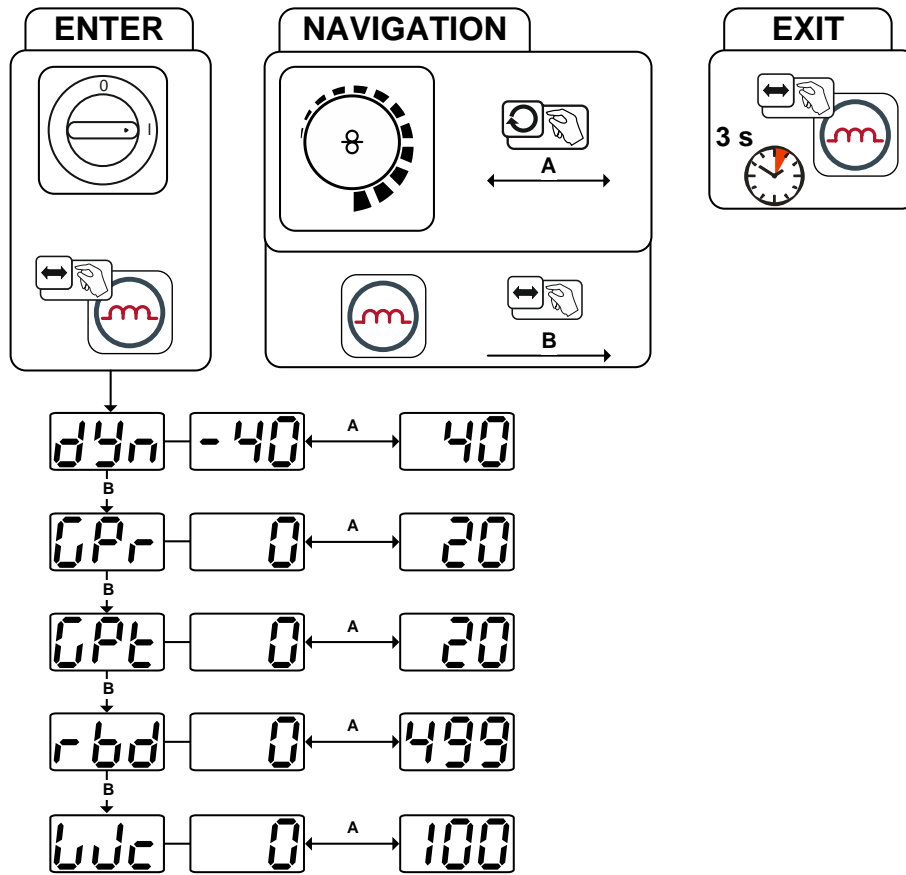













Figure 5-18

Display	Setting/selection
dyn	Dynamic correction <ul style="list-style-type: none"> • Increase value > harder arc • Decrease value > softer arc
GPr	Gas pre-flow time
GPl	Gas post-flow time
rbd	Correct wire burn-back <p>If too high a value is set, a large ball will form at the tip of the wire electrode (bad re-ignition) or the wire electrode sticks to the contact tip. If too low a value is set, the wire electrode sticks to the weld pool.</p> <ul style="list-style-type: none"> • Increase value > increase wire burn-back • Decrease value > decrease wire burn-back
Wc	Wire creep

5.3.5 MIG/MAG functional sequences / operating modes
5.3.5.1 Explanation of signs and functions

Symbol	Meaning
	Press torch trigger
	Release torch trigger
	Tap torch trigger (press briefly and release)
	Shielding gas flowing
I	Welding output
	Wire electrode is being conveyed
	Wire creep
	Wire burn-back
	Gas pre-flows
	Gas post-flows
	Non-latched
	Latched
t	Time
PSTART	Ignition program
PA	Main program
PEND	End program

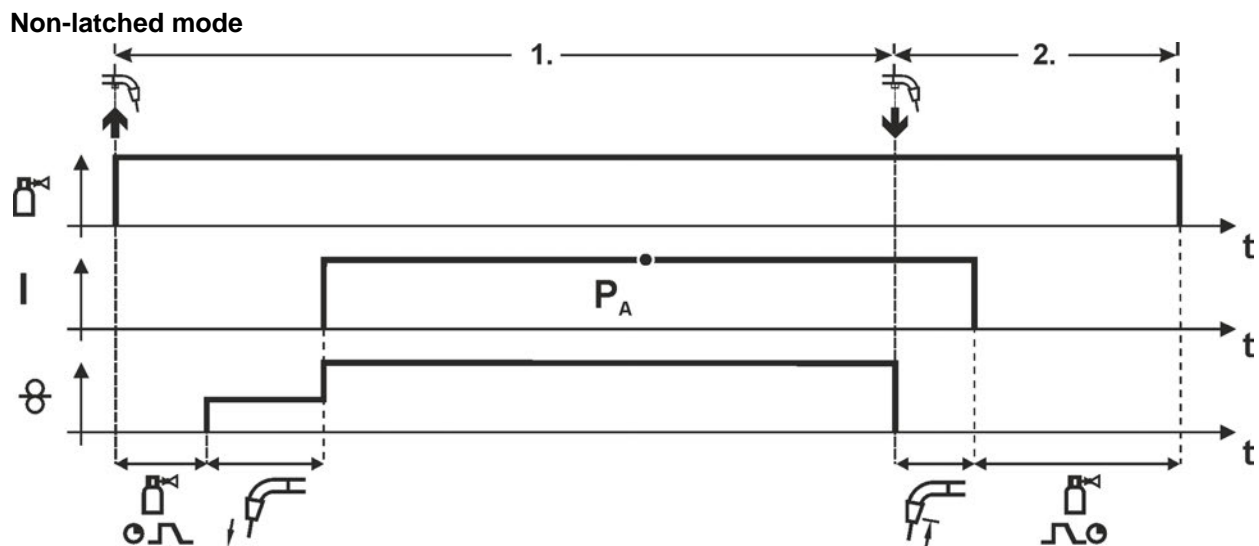

Figure 5-19

Step 1

- Press and hold torch trigger.
- Shielding gas is expelled (gas pre-flows).
- Wire feed motor runs at “creep speed”.
- Arc ignites after the wire electrode makes contact with the workpiece; welding current flows.
- Change over to pre-selected wire speed.

Step 2

- Release torch trigger.
- WF motor stops.
- Arc is extinguished after the preselected wire burn-back time expires.
- Gas post-flow time elapses.

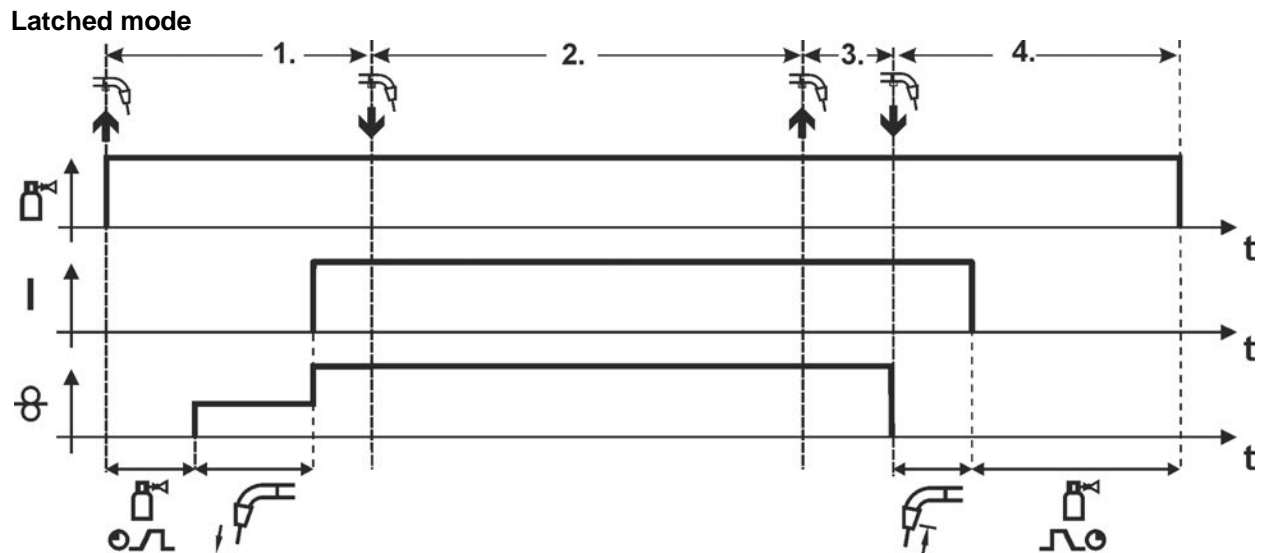

Figure 5-20

Step 1

- Press and hold torch trigger
- Shielding gas is expelled (gas pre-flows)
- Wire feed motor runs at “creep speed”.
- Arc ignites after the wire electrode makes contact with the workpiece; welding current flows.
- Change over to pre-selected WF speed (main program P_A).

Step 2

- Release torch trigger (no effect)

Step 3

- Press torch trigger (no effect)

Step 4

- Release torch trigger
- WF motor stops.
- Arc is extinguished after the preselected wire burn-back time expires.
- Gas post-flow time elapses.

5.3.6 Standard MIG/MAG torch

The MIG welding torch trigger is essentially used to start and stop the welding process.

Operating elements	Functions
 Torch trigger	<ul style="list-style-type: none"> • Start/stop welding

5.3.7 MIG/MAG special-torches

Function specifications and more indepth information can be found in the operating manual for the relevant welding torch!

5.4 MMA welding

CAUTION



Risk of being crushed or burnt.

When replacing spent or new stick electrodes

- Switch off machine at the main switch
- Wear appropriate safety gloves
- Use insulated tongs to remove spent stick electrodes or to move welded workpieces and
- Always put the electrode holder down on an insulated surface.

5.4.1 Connecting the electrode holder and workpiece lead

Figure 5-21

Item	Symbol	Description
1		Workpiece
2		Electrode holder
3		Connection socket, "-" welding current
4		Connection socket, "+" welding current

- Insert cable plug of the electrode holder into either the "+" or "-" welding current connection socket and lock by turning to the right.
- Insert cable plug of the workpiece lead into either the "+" or "-" welding current connection socket and lock by turning to the right.

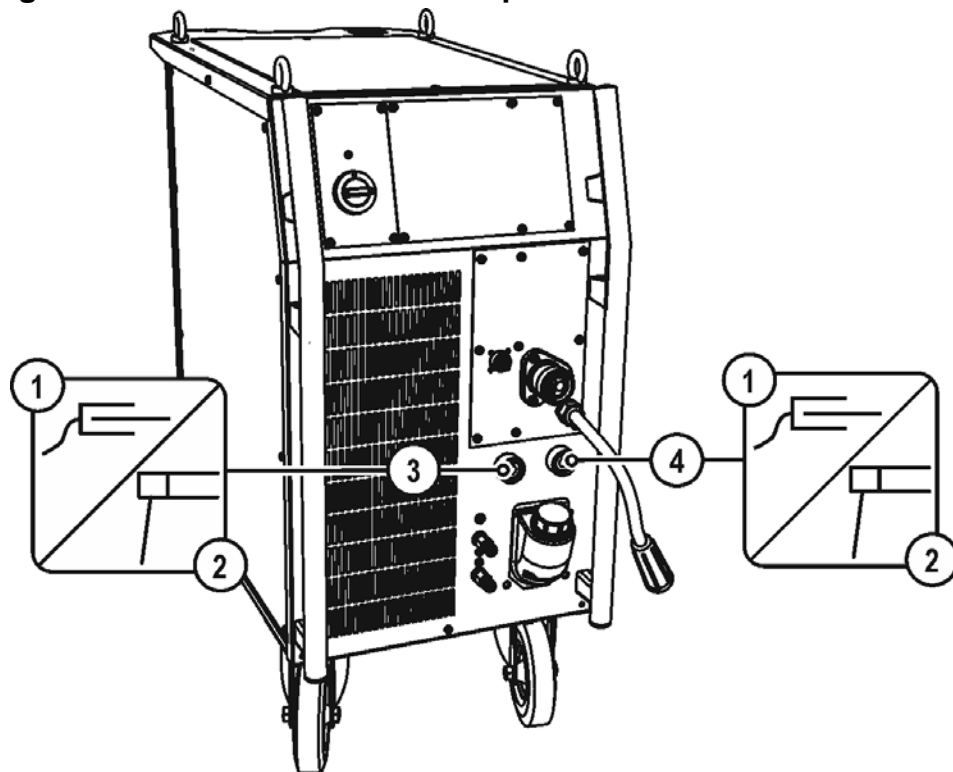

Polarity depends on the instructions from the electrode manufacturer given on the electrode packaging.

5.4.2 Welding task selection

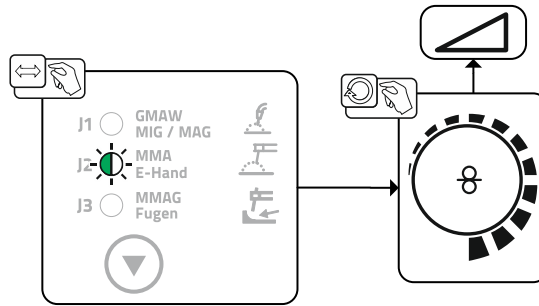

Figure 5-22

5.4.3 Arcforce

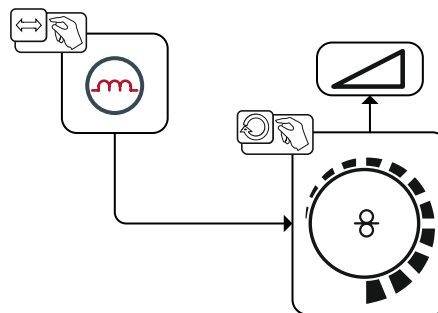

Figure 5-23

Setting:

- Negative values: rutile electrode types
- Values at zero: basic electrode types
- Positive values: cellulose electrode types

5.4.4 Hotstart

The hotstart device improves the ignition of the stick electrodes using an increased ignition current.

- a) = Hotstart time
- b) = Hotstart current
- I = Welding current
- t = Time

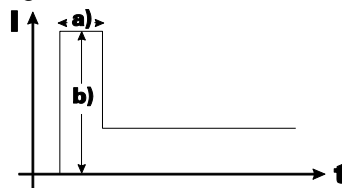
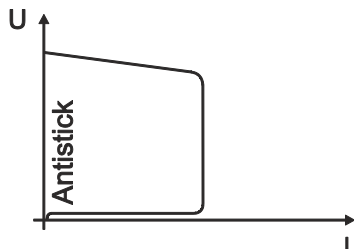

Figure 5-24

5.4.5 Antistick



Anti-stick prevents the electrode from annealing.

If the electrode sticks in spite of the Arcforce device, the machine automatically switches over to the minimum current within about 1 second to prevent the electrode from overheating. Check the welding current setting and correct according to the welding task!

Figure 5-25

5.4.6 Air arc gouging

5.4.6.1 Connection

Read and observe the documentation to all system and accessory components!

During gouging, an arc burns between a carbon electrode and the workpiece, heating the workpiece until it is molten. At the same time, the molten metal is blown out with compressed air. Special electrode holders with a compressed-air connection and carbon electrodes are required for gouging.

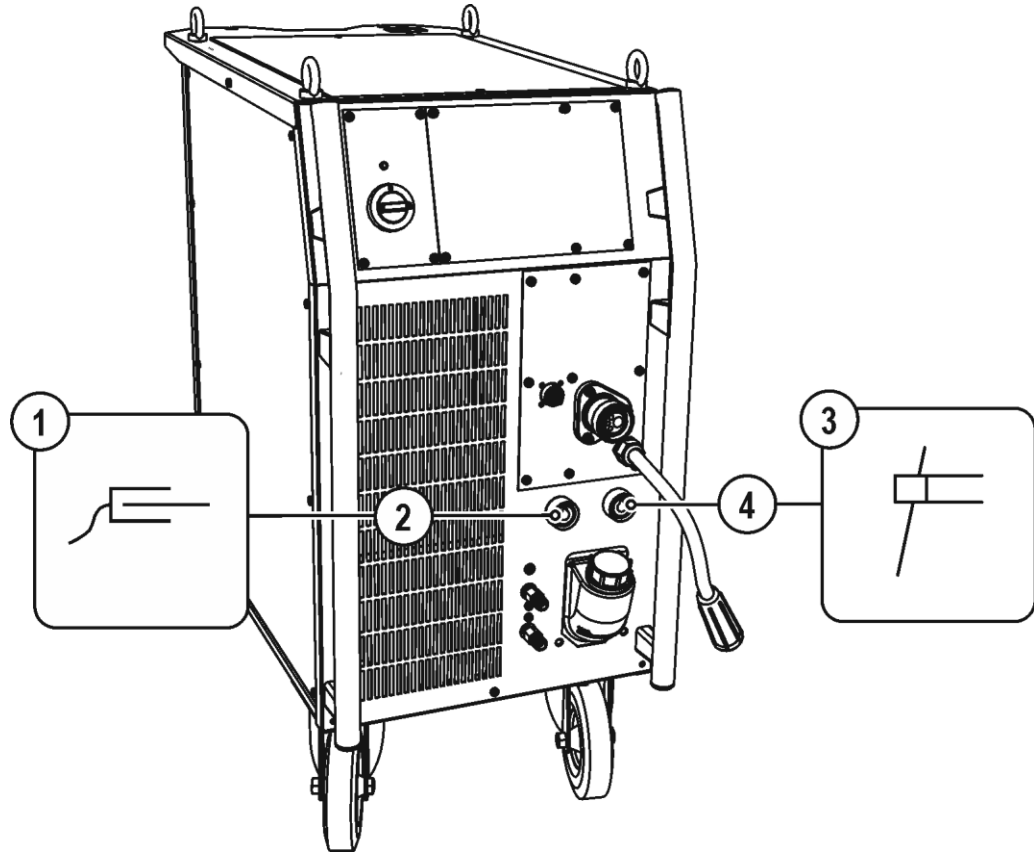

Figure 5-26

Item	Symbol	Description
1		Workpiece
2		Connection socket, "-" welding current
3		Gouging torch
4		Connection socket, "+" welding current

- Insert the gouging torch cable plug into the "+" welding current connection socket and lock in place by turning to the right.
- Insert cable plug on the workpiece lead into the "-" welding current socket and lock by turning to the right.

5.4.7 Welding task selection

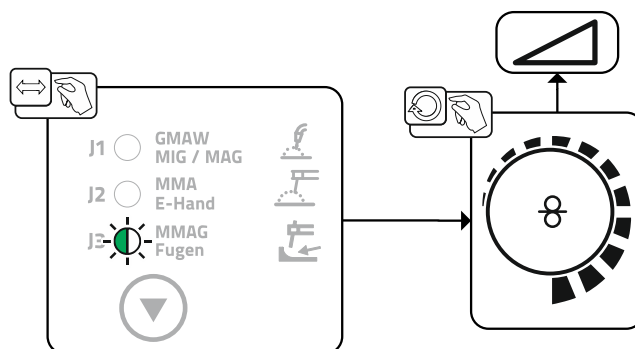

Figure 5-27

5.5 Remote control



The manufacturer's warranty becomes void if non-genuine parts are used!

- ***Only use system components and options (power sources, welding torches, electrode holders, remote controls, spare parts and replacement parts, etc.) from our range of products!***
- ***Only insert and lock accessory components into the relevant connection socket when the machine is switched off.***



The remote controls are operated on the 19-pole remote control connection socket (analogue).

5.6 Special parameters (advanced settings)

Special parameters (P1 to Pn) are applied for customer-specific configuration of machine functions. This allows the user maximum flexibility in optimising their requirements.

These settings are not configured directly on the machine control since a regular setting of the parameters is generally not required. The number of selectable special parameters can deviate between the machine controls used in the welding system (also see the relevant standard operating instructions). If required, the special parameters can be reset to the factory settings > see 5.6.1.1 chapter.

5.6.1 Selecting, changing and saving parameters



ENTER (Enter the menu)

- ***Switch off the machine at the main switch.***
- ***Press and hold the "operating mode" push-button and switch the machine on again at the same time.***

NAVIGATION (Navigate the menu)

- ***Select parameters by turning the "welding parameter setting" rotary knob.***
- ***Set or change the parameters by turning the "welding voltage" rotary knob.***

EXIT (Exit the menu)

- ***Press the "gas test" push-button (switch machine off and on again).***

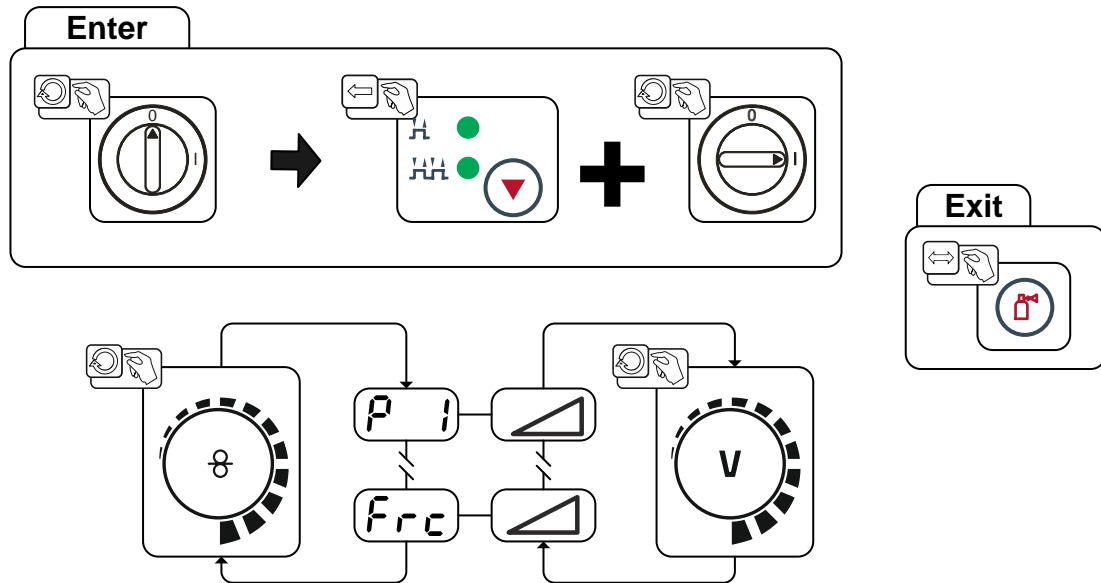

Figure 5-28

Display	Setting/selection
P 1	Ramp time for wire inching 0 = ----- normal inching (10s ramp time) 1 = ----- fast inching (3s ramp time) (Ex works)
P 9	Lat. and sp. lat. tapping start 0 = ----- no latched tapping start (Ex works) 1 = ----- latched tapping start possible
P22	Support for wire feeders with voltage-sensing. 0 = ----- Function switched off 1 = ----- Function switched on (ex works)
Frc	Remote control encoding (Frc) 0----- Automatic remote control detection (ex works) 2----- Remote control encoding for accessory components with a single rotary knob only 9----- Remote control encoding for accessory components with a single pair of buttons or a rocker only 1, 3-8 --- No remote control encoding 10-15 --- No remote control encoding

5.6.1.1 Reset to factory settings

 **All special parameters saved by the user will be overwritten by the factory settings!**

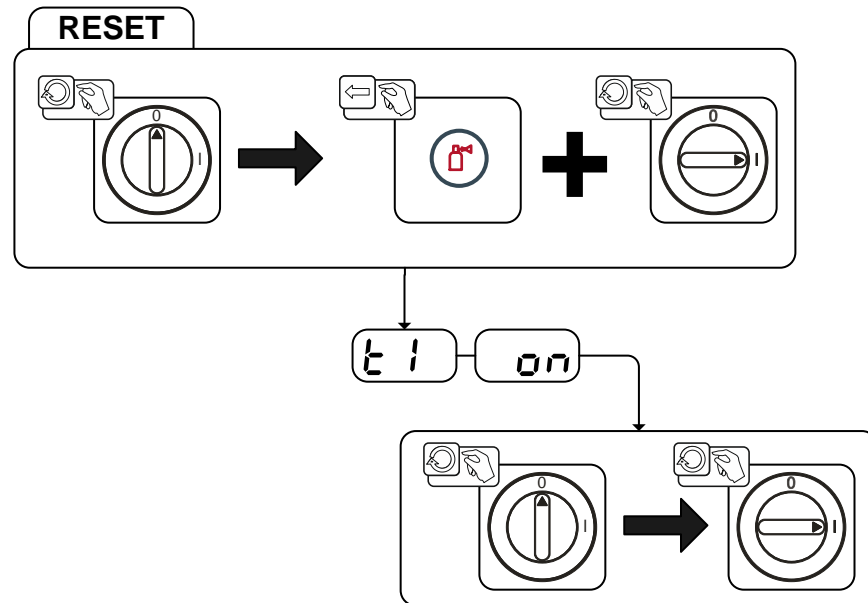
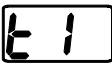

Figure 5-29

Display	Setting/selection
	Initialisation complete All customised welding parameters have been overwritten by the factory settings.

5.6.1.2 Special parameters in detail

Ramp time for wire inching (P1)

The wire inching starts with a speed 1.0 m/min for 2 secs. It is subsequently increased to a ramp function to 6.0 m/min. The ramp time can be set between two ranges.

During wire inching, the speed can be changed by means of the welding parameter setting rotary dial. Changing the speed has no effect on the ramp time.

Latched/special-latched tap start (P9)

In latched – tap start – operating mode it is possible to switch straight to the second step by tapping the torch trigger; it is not necessary for current to be flowing.

The welding can be halted by pressing the torch trigger for a second time.

Electronic gas flow control, type (P22)

Active only in machines with integrated gas flow control (option ex works).

Adjustment may only be carried out by authorised service personnel (basic setting = 1).

5.7 Machine configuration menu

5.7.1 Selecting, changing and saving parameters



ENTER (Enter the menu)

- Switch off the machine at the main switch.
- Press and hold down the "Welding procedure" push-button and switch the machine on again at the same time.

NAVIGATION (Navigate the menu)

- Select parameters by turning the "Welding parameter setting" rotary knob.
- Set or change the parameters by turning the "Welding voltage" rotary knob.

EXIT (Exit the menu)

- Press the "Push-button, parameter selection right" push-button (switch machine off and on again).

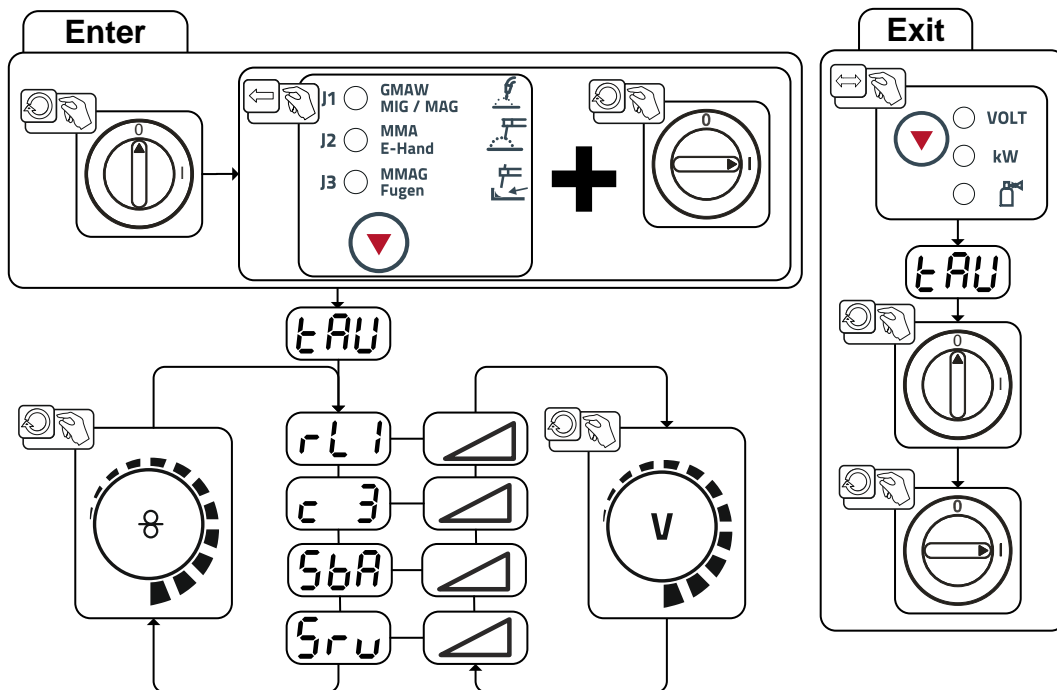

Figure 5-30

Display	Setting/selection
	Lead resistance 1 Lead resistance for the first welding circuit 0 mΩ–60 mΩ (8 mΩ ex works).
	Only qualified service personnel may change the parameters!
	Time-controlled power-saving mode > see 5.7.2 chapter <ul style="list-style-type: none"> • ----- 5 min.–60 min. = time until activation of power-saving mode when inactive. • ----- off = switched off
	Service menu Modifications to the service menu may only be carried out by authorised maintenance staff!

5.7.2 Power-saving mode (Standby)

You can activate the power-saving mode by either pressing the push-button > see 5.7 chapter for a prolonged time or by setting a parameter in the machine configuration menu (time-controlled power-saving mode **56A**) > see 5.7 chapter.



When power-saving mode is activated, the machine displays show the horizontal digit in the centre of the display only.

Pressing any operating element (e.g. tapping the torch trigger) deactivates power-saving mode and the machine is ready for welding again.

5.7.3 Aligning the cable resistance

The resistance value of the cables can be set directly or be aligned by the power source. In the delivery status the cable resistance of the power source is set to 8 mOhm. This value corresponds to a grounding cable of 5 m, an intermediate hose package of 1.5 m and a water-cooled welding torch of 3 m. The electric cable resistance should be aligned again whenever an accessory component, such as the welding torch or the intermediate hose package, has been changed.

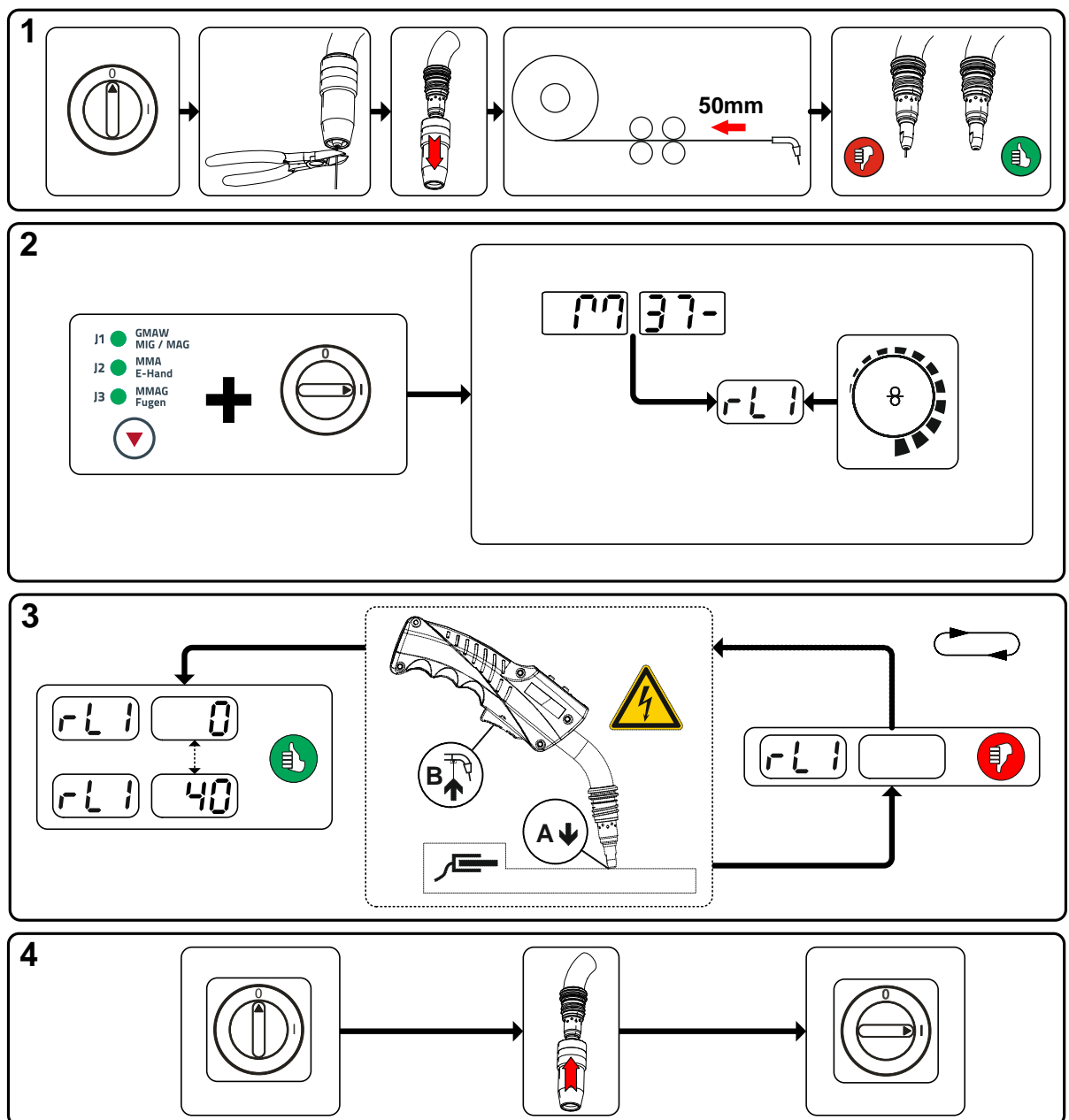

Figure 5-31

1 Preparation

- Switch off the welding machine.
- Unscrew the gas nozzle from the welding torch.
- Trim the welding wire so that it is flush with the contact tip.
- Retract the welding wire a little (approx. 50 mm) on the wire feeder. There should now be no more welding wire in the contact tip.

2 Configuration

- Press the "Welding procedure" push-button while simultaneously switching on the welding machine. Release push-button.
- The required parameter can now be selected using the 'Welding parameter setting' rotary knob. Parameter rL1 must be adjusted for all machine combinations.

3 Alignment/measurement

- Applying slight pressure, put the welding torch in place with the contact tip on a clean, purged location on the workpiece and then press the torch trigger for approx. 2 seconds. A short-circuit current will flow briefly, which is used to determine and display the cable resistance. The value can be between 0 mΩ and 40 mΩ. The new value is immediately saved without requiring further confirmation. If no value is shown on the right-hand display, then measurement failed. The measurement must be repeated.

4 Restoring welding standby mode

- Switch off the welding machine.
- Screw the gas nozzle onto the welding torch.
- Switch on the welding machine
- Insert the welding wire.

6 Maintenance, care and disposal

6.1 General

DANGER



Incorrect maintenance and testing!

The machine may be cleaned, repaired and tested by skilled and qualified personnel only. A qualified person is one who, due to their training, knowledge and experience, can detect any hazards and possible consequential damage when checking the machine, and can take the necessary safety measures.

- Observe the maintenance instructions > see 6.3 chapter!
- The machine may only be put into operation again once the testing has been successful.



Risk of injury due to electrical voltage after switching off!

Working on an open machine can lead to fatal injuries!

Capacitors are loaded with electrical voltage during operation. Voltage remains present for up to four minutes after the mains plug is removed.

1. Switch off machine.
2. Remove the mains plug.
3. Wait for at least 4 minutes until the capacitors have discharged!

WARNING



Cleaning, testing and repair!

Cleaning, testing and repairing of the welding machine may only be carried out by competent, qualified personnel. A qualified person is one who, because of his or her training, knowledge and experience, is able to recognise the dangers that can occur while testing welding power sources as well as possible subsequent damage, and who is able to implement the required safety procedures.

- In the event of failure of any one of the following tests, the machine must not be operated again until it has been repaired and a new test has been carried out.

Repair and maintenance work may only be performed by qualified authorised personnel; otherwise the right to claim under warranty is void. In all service matters, always consult the dealer who supplied the machine. Return deliveries of defective equipment subject to warranty may only be made through your dealer. When replacing parts, use only original spare parts. When ordering spare parts, please quote the machine type, serial number and item number of the machine, as well as the type designation and item number of the spare part.

Under the specified ambient conditions and normal working conditions this machine is essentially maintenance-free and requires just a minimum of care.

Contamination of the machine may impair service life and duty cycle. The cleaning intervals depend on the ambient conditions and the resulting contamination of the machine. The minimum interval is every six months.

6.2 Cleaning

- Clean the outer surfaces with a moist cloth (no aggressive cleaning agents).
- Purge the machine venting channel and cooling fins (if present) with oil- and water-free compressed air. Compressed air may overspeed and destroy the machine fans. Never direct the compressed air directly at the machine fans. Mechanically block the fans, if required.
- Check the coolant for contaminants and replace, if necessary.

6.3 Maintenance work, intervals

Repair and maintenance work may only be performed by qualified authorised personnel; otherwise the right to claim under warranty is void. In all service matters, always consult the dealer who supplied the machine. Return deliveries of defective equipment subject to warranty may only be made through your dealer. When replacing parts, use only original spare parts. When ordering spare parts, please quote the machine type, serial number and item number of the machine, as well as the type designation and item number of the spare part.

6.3.1 Daily maintenance tasks

6.3.1.1 Visual inspection

- Mains supply lead and its strain relief
- Gas cylinder securing elements
- Check hose package and power connections for exterior damage and replace or have repaired by specialist staff as necessary!
- Gas tubes and their switching equipment (solenoid valve)
- Check that all connections and wearing parts are hand-tight and tighten if necessary.
- Check correct mounting of the wire spool.
- Wheels and their securing elements
- Transport elements (strap, lifting lugs, handle)
- Other, general condition

6.3.1.2 Functional test

- Operating, message, safety and adjustment devices (Functional test)
- Welding current cables (check that they are fitted correctly and secured)
- Gas tubes and their switching equipment (solenoid valve)
- Gas cylinder securing elements
- Check correct mounting of the wire spool.
- Check that all screw and plug connections and replaceable parts are secured correctly, tighten if necessary.
- Remove any spatter.
- Clean the wire feed rollers on a regular basis (depending on the degree of soiling).

6.3.2 Monthly maintenance tasks

6.3.2.1 Visual inspection

- Casing damage (front, rear and side walls)
- Wheels and their securing elements
- Transport elements (strap, lifting lugs, handle)
- Check coolant tubes and their connections for impurities

6.3.2.2 Functional test

- Selector switches, command devices, emergency stop devices, voltage reducing devices, message and control lamps
- Check that the wire guide elements (inlet nipple, wire guide tube) are fitted securely.
- Check coolant tubes and their connections for impurities
- Check and clean the welding torch. Deposits in the torch can cause short circuits and have a negative impact on the welding result, ultimately causing damage to the torch.

6.3.3 Annual test (inspection and testing during operation)

 **The welding machine may only be tested by competent, capable persons!** A capable person is one who, because of his training, knowledge and experience, is able to recognise the dangers that can occur while testing welding power sources as well as possible subsequent damage and who is able to implement the required safety procedures.

 **For more information refer to the "Warranty registration" brochure supplied and our information regarding warranty, maintenance and testing at www.ewm-group.com!**

A periodic test according to IEC 60974-4 "Periodic inspection and test" has to be carried out. In addition to the regulations on testing given here, the relevant local laws and regulations must also be observed.

6.4 Disposing of equipment

 **Proper disposal!**

The machine contains valuable raw materials, which should be recycled, and electronic components, which must be disposed of.

- **Do not dispose of in household waste!**
- **Observe the local regulations regarding disposal!**



6.4.1 Manufacturer's declaration to the end user

- According to European provisions (guideline 2012/19/EU of the European Parliament and the Council of Juli, 4th 2021), used electric and electronic equipment may no longer be placed in unsorted municipal waste. It must be collected separately. The symbol depicting a waste container on wheels indicates that the equipment must be collected separately. This machine is to be placed for disposal or recycling in the waste separation systems provided for this purpose.
- According to German law (law governing the distribution, taking back and environmentally correct disposal of electric and electronic equipment (ElektroG) from 16.03.2005), used machines are to be placed in a collection system separate from unsorted municipal waste. The public waste management utilities (communities) have created collection points at which used equipment from private households can be disposed of free of charge.
- Information about giving back used equipment or about collections can be obtained from the respective municipal administration office.
- EWM participates in an approved waste disposal and recycling system and is registered in the Used Electrical Equipment Register (EAR) under number WEEE DE 57686922.
- In addition to this, returns are also possible throughout Europe via EWM sales partners.

6.5 Meeting the requirements of RoHS

We, EWM AG in Mündersbach, Germany, hereby confirm that all products which we supply to you and that are subject to the RoHS directive comply with RoHS requirements (also see applicable EC directives on the Declaration of Conformity on your machine).

7 Rectifying faults

All products are subject to rigorous production checks and final checks. If, despite this, something fails to work at any time, please check the product using the following flowchart. If none of the fault rectification procedures described leads to the correct functioning of the product, please inform your authorised dealer.

7.1 Checklist for rectifying faults



The correct machine equipment for the material and process gas in use is a fundamental requirement for perfect operation!

Legend	Symbol	Description
	↙	Fault/Cause
	✘	Remedy

Coolant error/no coolant flowing

- ↙ Insufficient coolant flow
 - ✘ Check coolant level and refill if necessary
- ↙ Air in the coolant circuit
 - ✘ Vent coolant circuit > see 7.4 chapter

Wire feed problems

- ↙ Contact tip blocked
 - ✘ Clean, spray with anti-spatter spray and replace if necessary
- ↙ Setting the spool brake > see 5.3.2.5 chapter
 - ✘ Check settings and correct if necessary
- ↙ Setting pressure units > see 5.3.2.4 chapter
 - ✘ Check settings and correct if necessary
- ↙ Worn wire rolls
 - ✘ Check and replace if necessary
- ↙ Wire feed motor without supply voltage (automatic cutout triggered by overloading)
 - ✘ Reset triggered fuse (rear of the power source) by pressing the key button
- ↙ Kinked hose packages
 - ✘ Extend and lay out the torch hose package
- ↙ Wire guide core or spiral is dirty or worn
 - ✘ Clean core or spiral; replace kinked or worn cores

Functional errors

- ↙ All machine control signal lights are illuminated after switching on
- ↙ No machine control signal light is illuminated after switching on
- ↙ No welding power
 - ✘ Phase failure > check mains connection (fuses)
- ↙ Connection problems
 - ✘ Make control lead connections and check that they are fitted correctly.
- ↙ Loose welding current connections
 - ✘ Tighten power connections on the torch and/or on the workpiece
 - ✘ Tighten contact tip correctly

7.2 Error messages (power source)

 **A welding machine error is indicated by an error code being displayed (see table) on the display on the machine control.**

In the event of a machine error, the power unit is shut down.

 **The display of possible error numbers depends on the machine version (interfaces/functions).**

- Document machine errors and inform service staff as necessary.
- If multiple errors occur, these are displayed in succession.





Error (Err)	Category			Possible cause	Remedy
	a)	b)	c)		
1	-	-	x	Mains overvoltage	Check the mains voltages and compare with the welding machine connection voltages
2	-	-	x	Mains undervoltage	
3	x	-	-	Welding machine excess temperature	Allow the machine to cool down (mains switch to "1")
4	x	x	-	Low coolant level	Top up the coolant Leak in the coolant circuit > repair the leak and top up the coolant Coolant pump is not working > check excess current trigger on air cooling unit
5	x	-	-	Wire feeder/tachometer error	Check the wire feeder Speedometer is not emitting a signal, M3.51 defective > inform Service.
6	x	-	-	Shielding gas error	Check shielding gas supply (for machines with shielding gas monitoring)
7	-	-	x	Secondary overvoltage	Inverter error > inform Service
8	-	-	x	Earth fault between welding wire and earth line	Separate the connection between welding wire and casing or an earthed object
9	x	-	-	Fast cut-out Triggered by BUSINT X11 or RINT X12	Rectify error on robot
10	-	x	-	Arc interruption Triggered by BUSINT X11 or RINT X12	Check wire feeding
11	-	x	-	Ignition error after 5 s Triggered by BUSINT X11 or RINT X12	Check wire feeding
13	x	-	-	Emergency stop deactivation	Check the emergency stop circuit at the interface for automated welding
14	-	x	-	Wire feeder not detected. Control cable not connected.	Check cable connections.
				Incorrect ID numbers assigned during operation with multiple wire feeders.	Check ID number assignation
15	-	x	-	Wire feeder 2 not detected. Control cable not connected.	Check cable connections.
16	-	-	x	VRD (open circuit voltage reduction error).	Inform Service.
17	-	x	x	Excess current detection on wire feeder	Check wire feeding
18	-	x	x	No speedometer signal from second wire feeder (slave drive)	Check the connection and particularly the speedometer for the second wire feeder (slave drive).
56	-	-	x	Mains phase failure	Check mains voltages

Error (Err)	Category			Possible cause	Remedy
	a)	b)	c)		
59	-	-	x	Machine incompatible	Check machine used
60	-	-	x	Software update required	Inform Service.

Legend for categories (reset error)

a) The error message will disappear once the error has been rectified.

b) The error message can be reset by pressing a push-button:

Welding machine control	Push-button
RC1 / RC2	
Expert	
Expert 2.0	
CarExpert / Progress (M3.11)	
alpha Q / Concept / Basic / Basic S / Synergic / Synergic S / Progress (M3.71) / Picomig 305	not possible

c) The error message can only be reset by switching the machine off and on again.

The shielding gas error (Err 6) can be reset by pressing the "Welding parameters" key button.

7.3 Welding parameter calibration

When differentiating between the welding parameters set on the wire feed unit/remote control and those shown on the welding machine, they can be calibrated easily with this function.

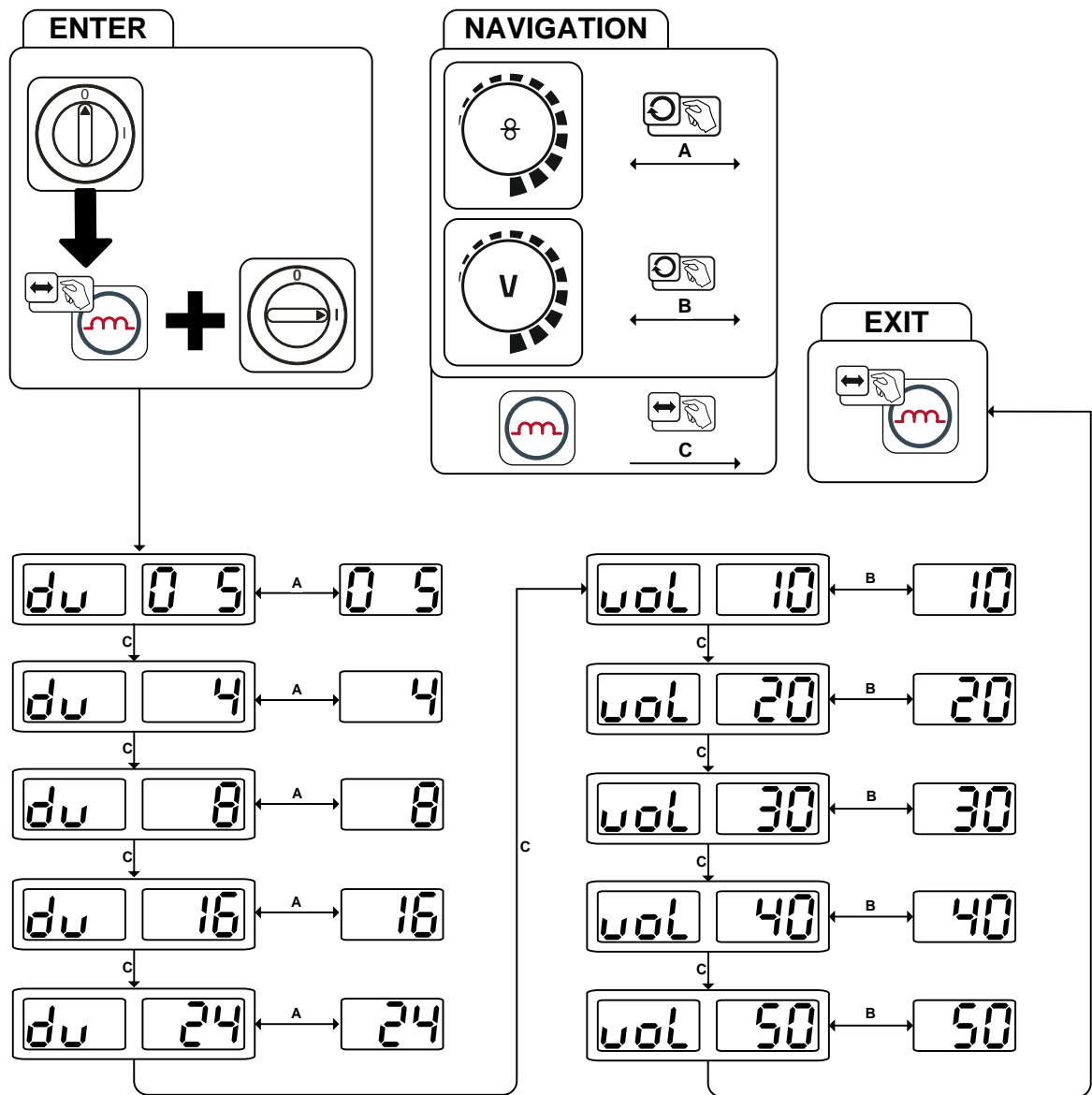

Figure 7-1

7.4 Vent coolant circuit

Coolant tank and quick connect coupling of coolant supply and return are only fitted in machines with water cooling.

To vent the cooling system always use the blue coolant connection, which is located as deep as possible inside the system (close to the coolant tank)!

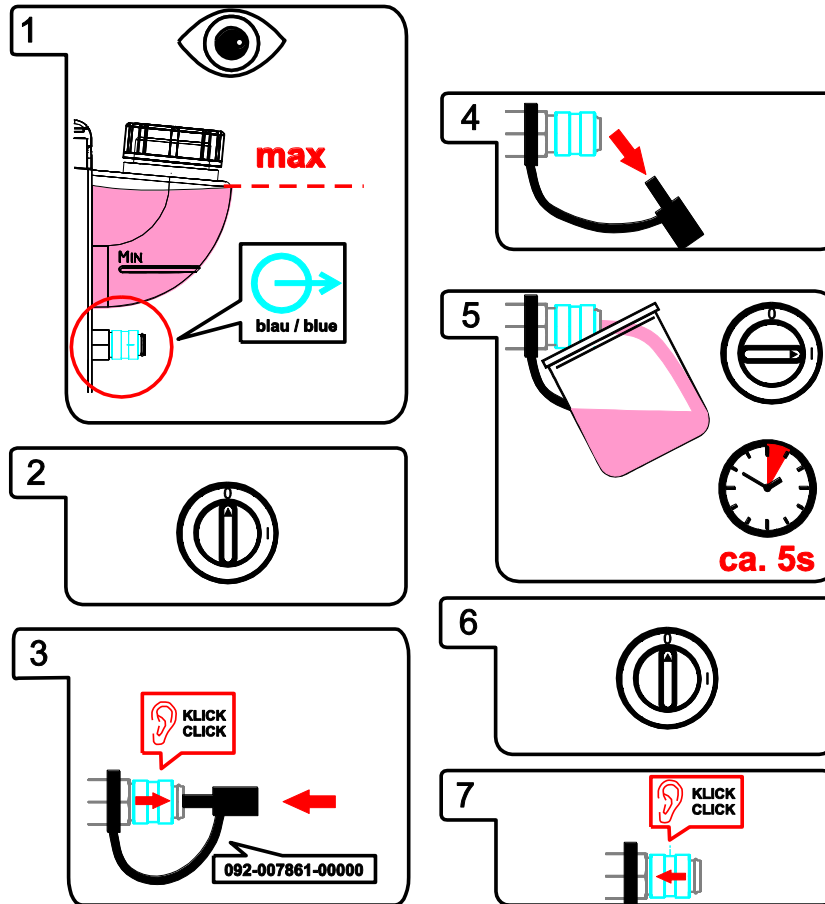

Figure 7-2

8 Technical data

 *Performance specifications and guarantee only in connection with original spare and replacement parts!*

8.1 Taurus 351 FKG

	MIG/MAG	MMA
Setting range for welding current	5 A to 350 A	
Setting range for welding voltage	14.3 V–31.5 V	20.2 V–34 V
Duty cycle at 40 °C		
100% DC	350 A	
Load cycle	10 min. (60% DC \triangle 6 min. welding, 4 min. pause)	
Open circuit voltage	79 V	
Mains voltage (tolerances)	3 x 400 V (-25% to +20%)	
Frequency	50/60 Hz	
Mains fuse (safety fuse, slow-blow)	3 x 25 A	
Mains connection lead	H07RN-F4G6	
Max. connected load	13.9 kVA	15.0 kVA
Recommended generator rating	20.3 kVA	
cos ϕ /efficiency	0.99/90%	
Ambient temperature	-25 °C to +40 °C	
Machine cooling/torch cooling	Fan (AF)/gas	
Workpiece lead	70 mm ²	
Insulation class/protection classification	H/IP 23	
EMC class	A	
Safety identification		
Other standards used	IEC 60974-1, -5, -10	
Wire spool diameter	Standardized wire spools up to 300 mm	
Wire feed speed	0.5 m/min. to 25 m/min.	
Standard roll installation	1.0 mm + 1.2 mm (for steel wire)	
Drive type	4 rolls (37 mm)	
Welding torch connection	Euro torch connector	
Dimensions L x W x H	1085 x 450 x 1003 mm	
	42.7 x 17.7 x 39.5 inch	
Weight	110 kg	
	242.5 lb	

8.2 Taurus 401 FKG

	MIG/MAG	MMA
Setting range for welding current	5 A to 400 A	
Setting range for welding voltage	14.3 V–34.0 V	20.2 V–36 V
Duty cycle at 40 °C		
100% DC	400 A	
Load cycle	10 min. (60% DC Δ 6 min. welding, 4 min. pause)	
Open circuit voltage	79 V	
Mains voltage (tolerances)	3 x 400 V (-25% to +20%)	
Frequency	50/60 Hz	
Mains fuse (safety fuse, slow-blow)	3 x 32 A	
Mains connection lead	H07RN-F4G6	
Max. connected load	17.2 kVA	18.2 kVA
Recommended generator rating	24.6 kVA	
cos ϕ /efficiency	0.99/90%	
Ambient temperature	-25 °C to +40 °C	
Machine cooling/torch cooling	Fan (AF)/gas	
Workpiece lead	70 mm ²	
Insulation class/protection classification	H/IP 23	
EMC class	A	
Safety identification		
Other standards used	IEC 60974-1, -5, -10	
Wire spool diameter	Standardized wire spools up to 300 mm	
Wire feed speed	0.5 m/min. to 25 m/min.	
Standard roll installation	1.0 mm + 1.2 mm (for steel wire)	
Drive type	4 rolls (37 mm)	
Welding torch connection	Euro torch connector	
Dimensions L x W x H	1085 x 450 x 1003 mm	
	42.7 x 17.7 x 39.5 inch	
Weight	110 kg	
	242.5 lb	

8.3 Taurus 351 FKW

	MIG/MAG	MMA
Setting range for welding current	5 A–350 A	
Setting range for welding voltage	14.3 V–31.5 V	20.2 V–34.0 V
Duty cycle at 40 °C		
100% DC	350 A	
Load cycle	10 min. (60% DC \triangle 6 min. welding, 4 min. pause)	
Open circuit voltage	79 V	
Mains voltage (tolerances)	3 x 400 V (-25% to +20%)	
Frequency	50/60 Hz	
Mains fuse (safety fuse, slow-blow)	3 x 25 A	
Mains connection lead	H07RN-F4G6	
Max. connected load	14.3 kVA	15.4 kVA
Recommended generator rating	20.8 kVA	
cos ϕ /efficiency	0.99/90%	
Ambient temperature*	-25 °C to +40 °C	
Machine cooling/torch cooling	Fan (AF)/gas or water	
Workpiece lead	70 mm ²	
Insulation class/protection classification	H/IP 23	
EMC class	A	
Safety identification		
Cooling capacity at 1 l/min.	1500 W	
Max. flow rate	5 l/min.	
Max. coolant outlet pressure	3.5 bar	
Tank capacity	12 l	
Wire feed speed	0.5 m/min. to 25 m/min.	
Standard roll installation	1.0 mm + 1.2 mm (for steel wire)	
Wire drive type	4 rolls (37 mm)	
Wire spool diameter	Standardized wire spools up to 300 mm	
Welding torch connection	Euro torch connector	
Dimensions L x W x H	1085 x 450 x 1003 mm	
	42.7 x 17.7 x 39.5 inch	
Weight	121.5 kg	
	267.9 lb	



**Ambient temperature depends on coolant! Observe the coolant temperature range for the welding torch cooling!*

8.4 Taurus 401 FKW

	MIG/MAG	MMA
Setting range for welding current	5 A–400 A	
Setting range for welding voltage	14.3 V–34.0 V	20.2 V–36.0 V
Duty cycle at 40 °C		
100% DC	400 A	
Load cycle	10 min. (60% DC Δ 6 min. welding, 4 min. pause)	
Open circuit voltage	79 V	
Mains voltage (tolerances)	3 x 400 V (-25% to +20%)	
Frequency	50/60 Hz	
Mains fuse (safety fuse, slow-blow)	3 x 32 A	
Mains connection lead	H07RN-F4G6	
Max. connected load	17.5 kVA	18.5 kVA
Recommended generator rating	25 kVA	
cos ϕ /efficiency	0.99/90%	
Ambient temperature*	-25 °C to +40 °C	
Machine cooling/torch cooling	Fan (AF)/gas or water	
Workpiece lead	70 mm ²	
Insulation class/protection classification	H/IP 23	
EMC class	A	
Safety identification		
Other standards used	IEC 60974-1, -2, -5, -10	
Cooling capacity at 1 l/min.	1500 W	
Max. flow rate	5 l/min.	
Max. coolant outlet pressure	3.5 bar	
Tank capacity	12 l	
Wire spool diameter	Standardized wire spools up to 300 mm	
Wire feed speed	0.5 m/min. to 25 m/min.	
Standard roll installation	1.0 mm + 1.2 mm (for steel wire)	
Wire drive type	4 rolls (37 mm)	
Welding torch connection	Euro torch connector	
Dimensions L x W x H	1085 x 450 x 1003 mm	
	42.7 x 17.7 x 39.5 inch	
Weight	121.5 kg	
	267.9 lb	



***Ambient temperature depends on coolant! Observe the coolant temperature range for the welding torch cooling!**

8.5 Taurus 501 FKW

	MIG/MAG	MMA
Setting range for welding current	5 A–500 A	
Setting range for welding voltage	14.3 V–39.0 V	20.2 V–40.0 V
Duty cycle at 40 °C		
60% DC	500 A	
100% DC	430 A	
Load cycle	10 min. (60% DC \triangle 6 min. welding, 4 min. pause)	
Open circuit voltage	79 V	
Mains voltage (tolerances)	3 x 400 V (-25% to +20%)	
Frequency	50/60 Hz	
Mains fuse (safety fuse, slow-blow)	3 x 32 A	
Mains connection lead	H07RN-F4G6	
Max. connected load	24.6 kVA	25.2 kVA
Recommended generator rating	34.0 kVA	
cos ϕ /efficiency	0.99/90%	
Ambient temperature*	-25 °C to +40 °C	
Machine cooling/torch cooling	Fan (AF)/gas or water	
Workpiece lead	95 mm ²	
Insulation class/protection classification	H/IP 23	
EMC class	A	
Safety identification		
Other standards used	IEC 60974-1, -2, -5, -10	
Cooling capacity at 1 l/min.	1500 W	
Max. flow rate	5 l/min.	
Max. coolant outlet pressure	3.5 bar	
Tank capacity	12 l	
Wire feed speed	0.5 m/min. to 25 m/min.	
Standard roll installation	1.0 mm + 1.2 mm (for steel wire)	
Wire drive type	4 rolls (37 mm)	
Wire spool diameter	Standardized wire spools up to 300 mm	
Welding torch connection	Euro torch connector	
Dimensions L x W x H	1085 x 450 x 1003	
	42.7 x 17.7 x 39.5 inch	
Weight	124.5 kg	
	274.5 lb	



***Ambient temperature depends on coolant! Observe the coolant temperature range for the welding torch cooling!**

9 Accessories



Performance-dependent accessories like torches, workpiece leads, electrode holders or intermediate hose packages are available from your authorised dealer.

9.1 General accessories

Type	Designation	Item no.
AK300	Wire spool adapter K300	094-001803-00001
DM 842 Ar/CO2 230bar 30l D	Pressure regulator with manometer	394-002910-00030
GH 2X1/4" 2M	Gas hose	094-000010-00001
5POLE/CEE/32A/M	Machine plug	094-000207-00000
HOSE BRIDGE UNI	Tube bridge	092-007843-00000
TYP 1	Frost protection tester	094-014499-00000
KF 23E-10	Coolant (-10 °C), 9.3 l	094-000530-00000
KF 23E-200	Coolant (-10 °C), 200 litres	094-000530-00001
KF 37E-10	Coolant (-20 °C), 9.3 l	094-006256-00000
KF 37E-200	Coolant (-20 °C), 200 l	094-006256-00001
SPL	Sharpener for plastic liners	094-010427-00000
HC PL	Hose cutter	094-016585-00000

9.2 Remote control / connection cable

Type	Designation	Item no.
R11 19POL	Remote control	090-008601-00502
RG11 19POL 5M	Remote control	090-008107-00000
RA5 19POL 5M	Remote control e.g. connection cable	092-001470-00005
RA10 19POL 10M	Remote control e.g. connection cable	092-001470-00010
RA20 19POL 20M	Remote control e.g. connection cable	092-001470-00020

9.3 Options

Type	Designation	Item no.
ON LB Wheels 160x40MM	Retrofit option for locking brake for machine wheels	092-002110-00000
ON Holder Gas Bottle <50L	Holding plate for gas cylinders smaller than 50 litres	092-002151-00000
ON Shock Protect	Ram protection retrofit option	092-002154-00000
ON Filter T/P	Retrofit option contamination filter for air inlet	092-002092-00000
ON Tool Box	Retrofit option tool box	092-002138-00000

10 Replaceable parts



The manufacturer's warranty becomes void if non-genuine parts are used!

- **Only use system components and options (power sources, welding torches, electrode holders, remote controls, spare parts and replacement parts, etc.) from our range of products!**
- **Only insert and lock accessory components into the relevant connection socket when the machine is switched off.**

10.1 Wire feed rollers

10.1.1 Wire feed rollers for steel wire

Type	Designation	Item no.
FE 4R 0.6 MM/0.023 INCH LIGHT PINK	Drive roll set, 37 mm, 4 rolls, V-groove for steel, stainless steel and brazing	092-002770-00006
FE 4R 0.8 MM/0.03 INCH WHITE	Drive roll set, 37 mm, 4 rolls, V-groove for steel, stainless steel and brazing	092-002770-00008
FE 4R 1.0 MM/0.04 INCH BLUE	Drive roll set, 37 mm, 4 rolls, V-groove for steel, stainless steel and brazing	092-002770-00010
FE 4R 1.2 MM/0.045 INCH RED	Drive roll set, 37 mm, 4 rolls, V-groove for steel, stainless steel and brazing	092-002770-00012
FE 4R 1.4 MM/0.052 INCH GREEN	Drive roll set, 37 mm, 4 rolls, V-groove for steel, stainless steel and brazing	092-002770-00014
FE 4R 1.6 MM/0.06 INCH BLACK	Drive roll set, 37 mm, 4 rolls, V-groove for steel, stainless steel and brazing	092-002770-00016
FE 4R 2.0 MM/0.08 INCH GREY	Drive roll set, 37 mm, 4 rolls, V-groove for steel, stainless steel and brazing	092-002770-00020
FE 4R 2.4 MM/0.095 INCH BROWN	Drive roll set, 37 mm, 4 rolls, V-groove for steel, stainless steel and brazing	092-002770-00024
FE 4R 2.8 MM/0.11 INCH LIGHT GREEN	Drive roll set, 37 mm, 4 rolls, V-groove for steel, stainless steel and brazing	092-002770-00028
FE 4R 3.2 MM/0.12 INCH VIOLET	Drive roll set, 37 mm, 4 rolls, V-groove for steel, stainless steel and brazing	092-002770-00032

10.1.2 Wire feed rollers for aluminium wire

Type	Designation	Item no.
AL 4R 0.8 MM/0.03 INCH WHITE	Drive roll set, 37 mm, for aluminium	092-002771-00008
AL 4R 1.0 MM/0.04 INCH BLUE	Drive roll set, 37 mm, for aluminium	092-002771-00010
AL 4R 1.2 MM/0.045 INCH RED	Drive roll set, 37 mm, for aluminium	092-002771-00012
AL 4R 1.6 MM/0.06 INCH BLACK	Drive roll set, 37 mm, for aluminium	092-002771-00016
AL 4R 2.0 MM/0.08 INCH GREY/YELLOW	Drive roll set, 37 mm, for aluminium	092-002771-00020
AL 4R 2.4 MM/0.095 INCH BROWN/YELLOW	Drive roll set, 37 mm, for aluminium	092-002771-00024
AL 4R 2.8 MM/0.110 INCH LIGHT GREEN/YELLOW	Drive roll set, 37 mm, for aluminium	092-002771-00028
AL 4R 3.2 MM/0.125 INCH VIOLET/YELLOW	Drive roll set, 37 mm, for aluminium	092-002771-00032

10.1.3 Wire feed rollers for cored wire

Type	Designation	Item no.
FUEL 4R 0.8 MM/0.03 INCH WHITE/ORANGE	Drive roll set, 37 mm, 4 rolls, V-groove/knurled for flux cored wire	092-002848-00008
FUEL 4R 1.0 MM/0.04 INCH BLUE/ORANGE	Drive roll set, 37 mm, 4 rolls, V-groove/knurled for flux cored wire	092-002848-00010
FUEL 4R 1.2 MM/0.045 INCH RED/ORANGE	Drive roll set, 37 mm, 4 rolls, V-groove/knurled for flux cored wire	092-002848-00012
FUEL 4R 1.4 MM/0.052 INCH GREEN/ORANGE	Drive roll set, 37 mm, 4 rolls, V-groove/knurled for flux cored wire	092-002848-00014
FUEL 4R 1.6 MM/0.06 INCH BLACK/ORANGE	Drive roll set, 37 mm, 4 rolls, V-groove/knurled for flux cored wire	092-002848-00016
FUEL 4R 2.0 MM/0.08 INCH GREY/ORANGE	Drive roll set, 37 mm, 4 rolls, V-groove/knurled for flux cored wire	092-002848-00020
FUEL 4R 2.4 MM/0.095 INCH BROWN/ORANGE	Drive roll set, 37 mm, 4 rolls, V-groove/knurled for flux cored wire	092-002848-00024

10.1.4 Wire guide

Type	Designation	Item no.
SET DRAHTFUERUNG	Wire guide set	092-002774-00000
ON WF 2,0-3,2MM EFEED	Retrofitting option, wire guide for 2.0–3.2 mm wires, eFeed drive	092-019404-00000
SET IG 4x4 1.6mm BL	Inlet guide set	092-002780-00000
GUIDE TUBE L105	Guide tube	094-006051-00000
CAPTUB L108 D1,6	Capillary tube	094-006634-00000
CAPTUB L105 D2,0/2,4	Capillary tube	094-021470-00000

11 Appendix A

11.1 Setting instructions













Basic  								mm							
 mm	 mm	SG2/3 G3/4 Si1 <small>Ar-90/CO₂-10 M20</small>		SG2/3 G3/4 Si1 <small>CO₂-100 / C1</small>		CrNi <small>Ar-98/CO₂-2 M12</small>		 inch	 inch	SG2/3 G3/4 Si1 <small>Ar-90/CO₂-10 M20</small>		SG2/3 G3/4 Si1 <small>CO₂-100 / C1</small>		CrNi <small>Ar-98/CO₂-2 M12</small>	
		 m/min	VOLT	 m/min	VOLT	 m/min	VOLT			 ipm	VOLT	 ipm	VOLT	 ipm	VOLT
0,8	0,8	2,0	15,1	2,0	15,7	2,4	13,6	.030	.030	080	15.1	080	15.7	095	13.6
	1,0	1,5	15,1	1,8	17,4	1,6	13,6		.040	060	15.1	070	17.4	065	13.6
1,0	0,8	2,6	15,4	2,7	16,3	3,0	14,5	.040	.030	100	15.4	105	16.3	120	14.5
	1,0	2,2	15,4	2,1	17,8	2,2	14,2		.040	085	15.4	085	17.8	085	14.2
	1,2	1,2	14,4	1,6	17,8	1,5	13,6		.045	045	14.4	065	17.8	060	13.6
2,0	0,8	5,5	17,4	4,8	19,0	6,9	18,3	.080	.030	215	17.4	190	19.0	270	18.3
	1,0	4,0	18,0	3,2	18,7	4,6	17,2		.040	155	18.0	125	18.7	180	17.2
	1,2	3,2	17,1	2,8	18,7	3,5	16,6		.045	125	17.1	110	18.7	140	16.6
3,0	0,8	8,8	19,2	9,2	26,5	10,5	19,6	.120	.030	345	19.2	360	26.5	415	19.6
	1,0	5,1	18,7	4,6	19,9	6,8	18,4		.040	200	18.7	180	19.9	270	18.4
	1,2	4,3	18,7	3,6	19,6	4,6	17,5		.045	170	18.7	140	19.6	180	17.5
4,0	0,8	10,8	20,8	12,0	28,9	12,8	21,4	.155	.030	425	20.8	470	28.9	505	21.4
	1,0	7,0	19,8	6,3	21,7	8,4	24,0		.040	275	19.8	250	21.7	330	24.0
	1,2	5,0	19,8	4,9	21,7	5,8	18,0		.045	195	19.8	195	21.7	230	18.0
5,0	0,8	14,0	21,9	14,2	30,9	14,6	24,3	.195	.030	550	21.9	560	30.9	575	24.3
	1,0	8,5	21,4	8,2	27,1	9,6	25,9		.040	335	21.4	325	27.1	380	25.9
	1,2	6,2	20,5	6,1	24,3	6,7	19,3		.045	245	20.5	240	24.3	265	19.3
6,0	0,8	17,8	23,2	18,6	32,7	17,5	26,5	.235	.030	700	23.2	730	32.7	690	26.5
	1,0	9,8	24,7	9,5	29,1	11,0	27,6		.040	385	24.7	375	29.1	435	27.6
	1,2	7,8	26,1	7,3	29,7	8,1	23,1		.045	305	26.1	285	29.7	320	23.1
8,0	0,8	22,0	27,1	21,8	34,8	21,0	28,8	.315	.030	865	27.1	860	34.8	825	28.8
	1,0	12,0	28,8	11,6	31,8	13,5	28,8		.040	470	28.8	455	31.8	530	28.8
	1,2	8,5	28,0	9,1	31,8	9,5	27,5		.045	335	28.0	360	31.8	375	27.5
10,0	1,0	14,8	30,6	14,2	34,9	15,5	30,0	.395	.040	585	30.6	560	34.9	610	30.0
	1,2	9,8	29,7	11,3	33,7	11,5	28,9		.045	385	29.7	445	33.7	455	28.9

Figure 11-1

12 Appendix B

12.1 Overview of EWM branches

Headquarters

EWM AG
Dr. Günter-Henle-Straße 8
56271 Mündersbach · Germany
Tel: +49 2680 181-0 · Fax: -244
www.ewm-group.com · info@ewm-group.com

Technology centre

EWM AG
Forststraße 7-13
56271 Mündersbach · Germany
Tel: +49 2680 181-0 · Fax: -144
www.ewm-group.com · info@ewm-group.com

Production, Sales and Service

EWM AG
Dr. Günter-Henle-Straße 8
56271 Mündersbach · Germany
Tel: +49 2680 181-0 · Fax: -244
www.ewm-group.com · info@ewm-group.com

EWM HIGHTEC WELDING s.r.o.
9. května 718 / 31
407 53 Jiříkov · Czech Republic
Tel.: +420 412 358-551 · Fax: -504
www.ewm-jirikov.cz · info@ewm-jirikov.cz

EWM HIGH TECHNOLOGY (Kunshan) Ltd.
10 Yuanshan Road, Kunshan · New & Hi-tech Industry Development Zone
Kunshan City · Jiangsu · Post code 215300 · People's Republic of China
Tel: +86 512 57867-188 · Fax: -182
www.ewm.cn · info@ewm.cn · info@ewm-group.cn

Sales and Service Germany

EWM AG
Sales and Technology Centre
Grünauer Fenn 4
14712 Rathenow · Tel: +49 3385 49402-0 · Fax: -20
www.ewm-rathenow.de · info@ewm-rathenow.de

EWM HIGHTEC WELDING GmbH
Centre Technology and mechanisation
Daimlerstr. 4-6
69469 Weinheim · Tel: +49 6201 84557-0 · Fax: -20
www.ewm-weinheim.de · info@ewm-weinheim.de

EWM AG
Rudolf-Winkel-Straße 7-9
37079 Göttingen · Tel: +49 551-3070713-0 · Fax: -20
www.ewm-goettingen.de · info@ewm-goettingen.de

EWM Schweißtechnik Handels GmbH
Karlsdorfer Straße 43
88069 Tettngang · Tel: +49 7542 97998-0 · Fax: -29
www.ewm-tettngang.de · info@ewm-tettngang.de

EWM AG
Dieselstraße 9b
50259 Pulheim · Tel: +49 2238-46466-0 · Fax: -14
www.ewm-pulheim.de · info@ewm-pulheim.de

EWM Schweißtechnik Handels GmbH
Heinkelstraße 8
89231 Neu-Ulm · Tel: +49 731 7047939-0 · Fax: -15
www.ewm-neu-ulm.de · info@ewm-neu-ulm.de

EWM AG
August-Horch-Straße 13a
56070 Koblenz · Tel: +49 261 963754-0 · Fax: -10
www.ewm-koblenz.de · info@ewm-koblenz.de

EWM AG
Eiserfelder Straße 300
57080 Siegen · Tel: +49 271 3878103-0 · Fax: -9
www.ewm-siegen.de · info@ewm-siegen.de

Sales and Service International

EWM HIGH TECHNOLOGY (Kunshan) Ltd.
10 Yuanshan Road, Kunshan · New & Hi-tech Industry Development Zone
Kunshan City · Jiangsu · Post code 215300 · People's Republic of China
Tel: +86 512 57867-188 · Fax: -182
www.ewm.cn · info@ewm.cn · info@ewm-group.cn

EWM HIGHTEC WELDING UK Ltd.
Unit 2B Coopies Way · Coopies Lane Industrial Estate
Morpeth · Northumberland · NE61 6JN · Great Britain
Tel: +44 1670 505875 · Fax: -514305
www.ewm-morpeth.co.uk · info@ewm-morpeth.co.uk

EWM HIGHTEC WELDING GmbH
Wiesenstraße 27b
4812 Pinsdorf · Austria · Tel: +43 7612 778 02-0 · Fax: -20
www.ewm-austria.at · info@ewm-austria.at

EWM HIGHTEC WELDING Sales s.r.o. / Prodejní a poradenské centrum
Tyršova 2106
256 01 Benešov u Prahy · Czech Republic
Tel: +420 317 729-517 · Fax: -712
www.ewm-benesov.cz · info@ewm-benesov.cz

Liaison office Turkey

EWM AG Türkiye İrtibat Bürosu
İkitelli OSB Mah. · Marmara Sanayi Sitesi P Blok Apt. No: 44
Küçükçekmece / İstanbul Türkiye
Tel.: +90 212 494 32 19
www.ewm-istanbul.com.tr · info@ewm-istanbul.com.tr

 Plants

 Branches

 Liaison office

● More than 400 EWM sales partners worldwide