

Power source

Phoenix 355 Expert 2.0 puls MM TDM
Phoenix 405 Expert 2.0 puls MM TDM
Phoenix 505 Expert 2.0 puls MM TDM

099-005352-EW501

Observe additional system documents!

13.01.2016

**Register now
and benefit!**
**Jetzt Registrieren
und Profitieren!**

www.ewm-group.com



General instructions

CAUTION



Read the operating instructions!

The operating instructions provide an introduction to the safe use of the products.

- Read the operating instructions for all system components!
- Observe accident prevention regulations!
- Observe all local regulations!
- Confirm with a signature where appropriate.



In the event of queries on installation, commissioning, operation or special conditions at the installation site, or on usage, please contact your sales partner or our customer service department on +49 2680 181-0.

A list of authorised sales partners can be found at www.ewm-group.com.

Liability relating to the operation of this equipment is restricted solely to the function of the equipment. No other form of liability, regardless of type, shall be accepted. This exclusion of liability shall be deemed accepted by the user on commissioning the equipment.

The manufacturer is unable to monitor whether or not these instructions or the conditions and methods are observed during installation, operation, usage and maintenance of the equipment. An incorrectly performed installation can result in material damage and injure persons as a result. For this reason, we do not accept any responsibility or liability for losses, damages or costs arising from incorrect installation, improper operation or incorrect usage and maintenance or any actions connected to this in any way.

© EWM AG · Dr. Günter-Henle-Str. 8 · D-56271 Mündersbach, Germany

The copyright to this document remains the property of the manufacturer.

Reprinting, including extracts, only permitted with written approval.

The content of this document has been prepared and reviewed with all reasonable care. The information provided is subject to change, errors excepted.

1 Contents

1	Contents	3
2	Safety instructions	6
2.1	Notes on the use of these operating instructions	6
2.2	Explanation of icons.....	8
2.3	General	9
2.4	Transport and installation	13
2.4.1	Ambient conditions	14
2.4.1.1	In operation	14
2.4.1.2	Transport and storage.....	14
3	Intended use	15
3.1	Documents which also apply	15
3.1.1	Warranty	15
3.1.2	Declaration of Conformity.....	15
3.1.3	Welding in environments with increased electrical hazards.....	15
3.1.4	Service documents (spare parts and circuit diagrams).....	15
3.1.5	Calibration/Validation	15
4	Machine description – quick overview	16
4.1	Front view	16
4.2	Rear view.....	18
5	Design and function	20
5.1	General	20
5.2	Transport and installation	22
5.3	Machine cooling.....	22
5.4	Workpiece lead, general	22
5.5	Mains connection.....	23
5.5.1	Mains configuration	23
5.6	Notes on the installation of welding current leads	24
5.7	Welding torch cooling system	26
5.7.1	List of coolants.....	26
5.7.2	Maximal hose package length.....	26
5.7.3	Cooling module connection	27
5.8	Aligning the cable resistance	28
5.9	Connecting the intermediate hose package to the power source	30
5.9.1	Intermediate hose package strain relief	30
5.9.2	Intermediate hose package connection	31
5.9.3	Shielding gas supply (shielding gas cylinder for welding machine)	32
5.10	Welding torch holder.....	33
5.11	MIG/MAG welding.....	34
5.11.1	Connection for workpiece lead	34
5.12	TIG welding.....	35
5.12.1	Welding torch connection	35
5.12.2	Connection for workpiece lead	35
5.13	MMA welding	36
5.13.1	Connecting the electrode holder and workpiece lead	36
5.14	Remote control.....	37
5.15	Interfaces	37
5.15.1	Automation interface	38
5.15.2	RINT X12 robot interface.....	39
5.15.3	BUSINT X11 Industrial bus interface.....	39
5.16	PC Interfaces	39
6	Maintenance, care and disposal	40
6.1	General	40
6.2	Maintenance work, intervals	40
6.2.1	Daily maintenance tasks	40
6.2.1.1	Visual inspection	40
6.2.1.2	Functional test.....	40

6.2.2	Monthly maintenance tasks	41
6.2.2.1	Visual inspection	41
6.2.2.2	Functional test	41
6.2.3	Annual test (inspection and testing during operation)	41
6.3	Disposing of equipment.....	41
6.3.1	Manufacturer's declaration to the end user	41
6.4	Meeting the requirements of RoHS.....	41
7	Rectifying faults.....	42
7.1	Checklist for rectifying faults	42
7.2	General operating problems	43
7.2.1	Interface for automated welding	43
7.3	Vent coolant circuit.....	43
8	Technical data.....	44
8.1	Phoenix 355 TDM	44
8.2	Phoenix 405	45
8.3	Phoenix 505	46
9	Accessories	47
9.1	Wire feed units	47
9.2	Options.....	47
9.3	Welding torch cooling system	47
9.4	Transport systems.....	47
9.5	Remote control / connection cable.....	47
9.5.1	7-pole connection	47
9.6	General accessories	47
10	Appendix A.....	48
10.1	Overview of EWM branches.....	48

2 Safety instructions

2.1 Notes on the use of these operating instructions

DANGER

Working or operating procedures which must be closely observed to prevent imminent serious and even fatal injuries.

- Safety notes include the "DANGER" keyword in the heading with a general warning symbol.
- The hazard is also highlighted using a symbol on the edge of the page.

WARNING

Working or operating procedures which must be closely observed to prevent serious and even fatal injuries.

- Safety notes include the "WARNING" keyword in the heading with a general warning symbol.
- The hazard is also highlighted using a symbol in the page margin.

CAUTION

Working or operating procedures which must be closely observed to prevent possible minor personal injury.

- The safety information includes the "CAUTION" keyword in its heading with a general warning symbol.
- The risk is explained using a symbol on the edge of the page.

CAUTION

Working and operating procedures which must be followed precisely to avoid damaging or destroying the product.

- The safety information includes the "CAUTION" keyword in its heading without a general warning symbol.
- The hazard is explained using a symbol at the edge of the page.

Special technical points which users must observe.

Instructions and lists detailing step-by-step actions for given situations can be recognised via bullet points, e.g.:

- Insert the welding current lead socket into the relevant socket and lock.

WARNING



Validity of the document!

This document is part of the complete documentation and valid only in combination with the "Power source" operating instructions for the product being used!

- Read and observe the operating instructions for all system components, especially the safety instructions!

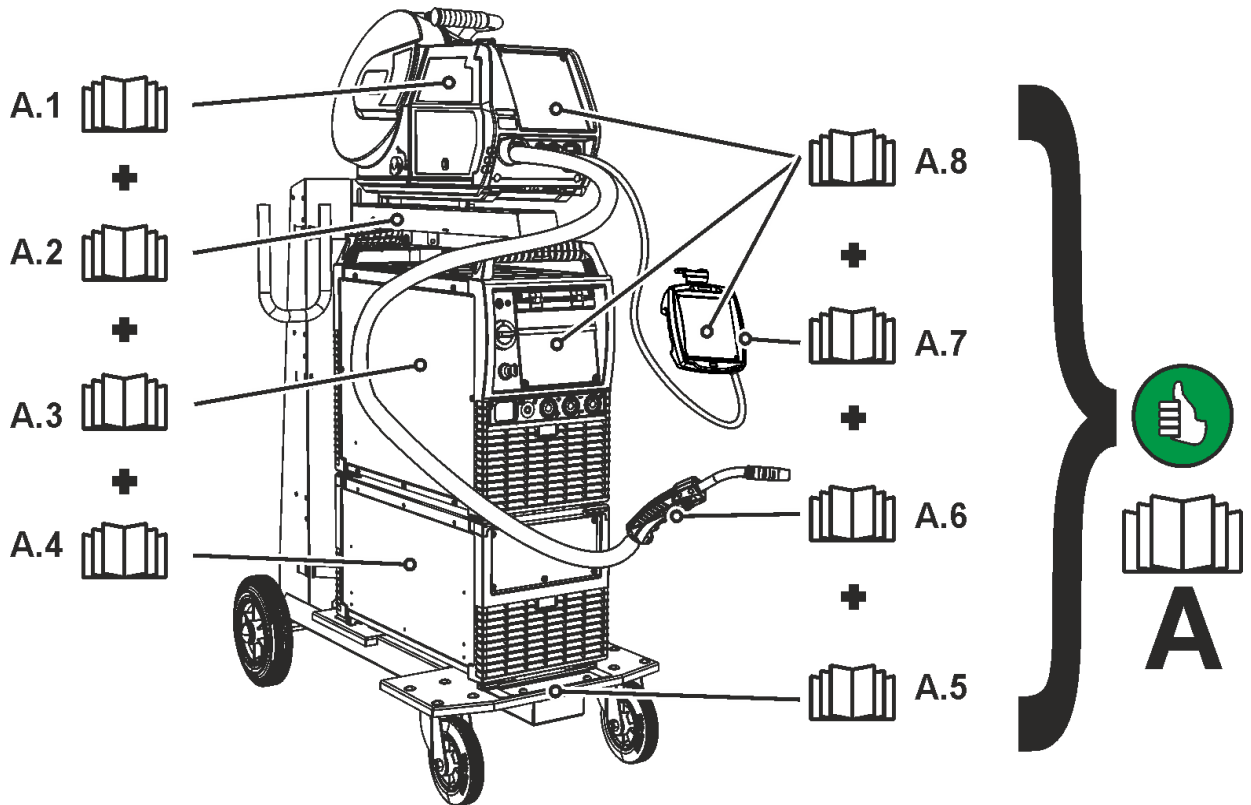

Figure 2-1

The illustration shows a general example of a welding system.

Item	Documentation
A.1	Wire feeder
A.2	Conversion instructions xxx
A.3	Power source
A.4	Cooling unit, voltage converter, tool box etc.
A.5	Trolley
A.6	Welding torch
A.7	Remote control
A.8	Control
A	Complete documentation

2.2 Explanation of icons

Symbol	Description	Symbol	Description
	Indicates technical aspects which the user must observe.		Activate and release/tap/tip
	Switch off machine		Release/do not activate
	Switch on machine		Press and hold/switch
	Wrong		Turn
	Correct		Signal light off
	Menu entry		Signal light on (e.g. green), colour code: g=green, r=red, y=yellow
	Navigating the menu		Signal light flashing (e.g. green), colour code: g=green, r=red, y=yellow
	Exit menu		Time representation (e.g.: wait 4 s/activate)
	Tool not required/do not use		Interruption in the menu display (other setting options possible)
	Tool required/use		

2.3 General

DANGER



Electromagnetic fields!

The power source may cause electrical or electromagnetic fields to be produced which could affect the correct functioning of electronic equipment such as IT or CNC devices, telecommunication lines, power cables, signal lines and pacemakers.

- Observe the maintenance instructions - See 6 Maintenance, care and disposal chapter!
- Unwind welding leads completely!
- Shield devices or equipment sensitive to radiation accordingly!
- The correct functioning of pacemakers may be affected (obtain advice from a doctor if necessary).



Do not carry out any unauthorised repairs or modifications!

To avoid injury and equipment damage, the unit must only be repaired or modified by specialist, skilled persons!

The warranty becomes null and void in the event of unauthorised interference.

- Appoint only skilled persons for repair work (trained service personnel)!



Electric shock!

Welding machines use high voltages which can result in potentially fatal electric shocks and burns on contact. Even low voltages can cause you to get a shock and lead to accidents.

- Do not touch any live parts in or on the machine!
- Connection cables and leads must be free of faults!
- Switching off alone is not sufficient!
- Place welding torch and stick electrode holder on an insulated surface!
- The unit should only be opened by specialist staff after the mains plug has been unplugged!
- Only wear dry protective clothing!
- Wait for 4 minutes until the capacitors have discharged!

WARNING



Risk of injury due to radiation or heat!

Arc radiation results in injury to skin and eyes.

Contact with hot workpieces and sparks results in burns.

- Use welding shield or welding helmet with the appropriate safety level (depending on the application)!
- Wear dry protective clothing (e.g. welding shield, gloves, etc.) according to the relevant regulations in the country in question!
- Protect persons not involved in the work against arc beams and the risk of glare using safety curtains!



Explosion risk!

Apparently harmless substances in closed containers may generate excessive pressure when heated.

- Move containers with inflammable or explosive liquids away from the working area!
- Never heat explosive liquids, dusts or gases by welding or cutting!

WARNING



Smoke and gases!

Smoke and gases can lead to breathing difficulties and poisoning. In addition, solvent vapour (chlorinated hydrocarbon) may be converted into poisonous phosgene due to the ultraviolet radiation of the arc!

- Ensure that there is sufficient fresh air!
- Keep solvent vapour away from the arc beam field!
- Wear suitable breathing apparatus if appropriate!



Fire hazard!

Flames may arise as a result of the high temperatures, stray sparks, glowing-hot parts and hot slag produced during the welding process.

Stray welding currents can also result in flames forming!

- Check for fire hazards in the working area!
- Do not carry any easily flammable objects such as matches or lighters.
- Keep appropriate fire extinguishing equipment to hand in the working area!
- Thoroughly remove any residue of flammable substances from the workpiece before starting welding.
- Only continue work on welded workpieces once they have cooled down.
Do not allow to come into contact with flammable material!
- Connect welding leads correctly!



Risk of accidents due to non-compliance with the safety instructions!

Non-compliance with the safety instructions can be fatal!

- Carefully read the safety instructions in this manual!
- Observe the accident prevention regulations and any regional regulations!
- Inform persons in the working area that they must comply with the regulations!



Danger when coupling multiple power sources!

Coupling multiple power sources in parallel or in series has to be carried out by qualified personnel and in accordance with the manufacturer's guidelines. Before bringing the power sources into service for arc welding operations, a test has to verify that they cannot exceed the maximum allowed open circuit voltage.

- Connection of the machine may be carried out by qualified personnel only!
- When decommissioning individual power sources, all mains and welding current leads have to be safely disconnected from the welding system as a whole. (Danger due to inverse voltages!)
- Do not couple welding machines with pole reversing switch (PWS series) or machines for AC welding, as a minor error in operation can cause the welding voltages to be combined.

CAUTION



Noise exposure!

Noise exceeding 70 dBA can cause permanent hearing damage!

- Wear suitable ear protection!
- Persons located within the working area must wear suitable ear protection!

CAUTION**Obligations of the operator!****The respective national directives and laws must be observed for operation of the machine!**

- National implementation of the framework directive (89/391/EEG), as well as the associated individual directives.
- In particular, directive (89/655/EEG), on the minimum regulations for safety and health protection when staff members use equipment during work.
- The regulations regarding work safety and accident prevention for the respective country.
- Setting up and operating the machine according to IEC 60974-9.
- Check at regular intervals that users are working in a safety-conscious way.
- Regular checks of the machine according to IEC 60974-4.

**Damage due to the use of non-genuine parts!****The manufacturer's warranty becomes void if non-genuine parts are used!**

- Only use system components and options (power sources, welding torches, electrode holders, remote controls, spare parts and replacement parts, etc.) from our range of products!
- Only insert and lock accessory components into the relevant connection socket when the machine is switched off.

**Damage to the machine due to stray welding currents!****Stray welding currents can destroy protective earth conductors, damage equipment and electronic devices and cause overheating of components leading to fire.**

- Make sure all welding leads are securely connected and check regularly.
- Always ensure a proper and secure electrical connection to the workpiece!
- Set up, attach or suspend all conductive power source components like casing, transport vehicle and crane frames so they are insulated!
- Do not place any other electronic devices such as drillers or angle grinders, etc., on the power source, transport vehicle or crane frames unless they are insulated!
- Always put welding torches and electrode holders on an insulated surface when they are not in use!

**Mains connection****Requirements for connection to the public mains network**

High-performance machines can influence the mains quality by taking current from the mains network. For some types of machines, connection restrictions or requirements relating to the maximum possible line impedance or the necessary minimum supply capacity at the interface with the public network (Point of Common Coupling, PCC) can therefore apply. In this respect, attention is also drawn to the machines' technical data. In this case, it is the responsibility of the operator, where necessary in consultation with the mains network operator, to ensure that the machine can be connected.

CAUTION



EMC Machine Classification

In accordance with IEC 60974-10, welding machines are grouped in two electromagnetic compatibility classes - See 8 Technical data chapter:

Class A machines are not intended for use in residential areas where the power supply comes from the low-voltage public mains network. When ensuring the electromagnetic compatibility of class A machines, difficulties can arise in these areas due to interference not only in the supply lines but also in the form of radiated interference.

Class B machines fulfil the EMC requirements in industrial as well as residential areas, including residential areas connected to the low-voltage public mains network.

Setting up and operating

When operating arc welding systems, in some cases, electro-magnetic interference can occur although all of the welding machines comply with the emission limits specified in the standard. The user is responsible for any interference caused by welding.

In order to **evaluate** any possible problems with electromagnetic compatibility in the surrounding area, the user must consider the following: (see also EN 60974-10 Appendix A)

- Mains, control, signal and telecommunication lines
- Radios and televisions
- Computers and other control systems
- Safety equipment
- The health of neighbouring persons, especially if they have a pacemaker or wear a hearing aid
- Calibration and measuring equipment
- The immunity to interference of other equipment in the surrounding area
- The time of day at which the welding work must be carried out

Recommendations for **reducing interference emission**

- Mains connection, e.g. additional mains filter or shielding with a metal tube
- Maintenance of the arc welding equipment
- Welding leads should be as short as possible and run closely together along the ground
- Potential equalization
- Earthing of the workpiece. In cases where it is not possible to earth the workpiece directly, it should be connected by means of suitable capacitors.
- Shielding from other equipment in the surrounding area or the entire welding system

2.4 Transport and installation

WARNING



Incorrect handling of shielding gas cylinders!

Incorrect handling of shielding gas cylinders can result in serious and even fatal injury.

- Observe the instructions from the gas manufacturer and in any relevant regulations concerning the use of compressed air!
- Place shielding gas cylinders in the holders provided for them and secure with fixing devices.
- Avoid heating the shielding gas cylinder!



Risk of accident due to improper transport of machines that may not be lifted!

Do not lift or suspend the machine! The machine can fall down and cause injuries! The handles and brackets are suitable for transport by hand only!

- The machine may not be lifted by crane or suspended!

CAUTION



Risk of tipping!

There is a risk of the machine tipping over and injuring persons or being damaged itself during movement and set up. Tilt resistance is guaranteed up to an angle of 10° (according to IEC 60974-1).

- Set up and transport the machine on level, solid ground.
- Secure add-on parts using suitable equipment.



Damage due to supply lines not being disconnected!

During transport, supply lines which have not been disconnected (mains supply leads, control leads, etc.) may cause hazards such as connected equipment tipping over and injuring persons!

- Disconnect supply lines!

CAUTION



Equipment damage when not operated in an upright position!

The units are designed for operation in an upright position!

Operation in non-permissible positions can cause equipment damage.

- Only transport and operate in an upright position!

2.4.1 Ambient conditions

CAUTION



Installation site!

The machine must not be operated in the open air and must only be set up and operated on a suitable, stable and level base!

- The operator must ensure that the ground is non-slip and level, and provide sufficient lighting for the place of work.
- Safe operation of the machine must be guaranteed at all times.

CAUTION



Equipment damage due to dirt accumulation!

Unusually high quantities of dust, acid, corrosive gases or substances may damage the equipment.

- Avoid high volumes of smoke, vapour, oil vapour and grinding dust!
- Avoid ambient air containing salt (sea air)!



Non-permissible ambient conditions!

Insufficient ventilation results in a reduction in performance and equipment damage.

- Observe the ambient conditions!
- Keep the cooling air inlet and outlet clear!
- Observe the minimum distance of 0.5 m from obstacles!

2.4.1.1 In operation

Temperature range of the ambient air:

- -25 °C to +40 °C

Relative air humidity:

- Up to 50% at 40 °C
- Up to 90% at 20 °C

2.4.1.2 Transport and storage

Storage in an enclosed space, temperature range of the ambient air:

- -30 °C to +70 °C

Relative air humidity

- Up to 90% at 20 °C

3 Intended use

WARNING



Hazards due to improper usage!

Hazards may arise for persons, animals and material objects if the equipment is not used correctly. No liability is accepted for any damages arising from improper usage!

- The equipment must only be used in line with proper usage and by trained or expert staff!
- Do not modify or convert the equipment improperly!

Arc welding machine for standard and pulsed gas-shielded metal-arc welding with TIG welding and lift arc (touch starting) or MMA welding as secondary process. It may be possible to expand the functionality by using accessories (see the documentation in the relevant chapter).



A suitable wire feed unit (system component) is required in order to operate the welding machine!

3.1 Documents which also apply

3.1.1 Warranty



For more information refer to the "Warranty registration" brochure supplied and our information regarding warranty, maintenance and testing at www.ewm-group.com!

3.1.2 Declaration of Conformity



The designated machine conforms to EC Directives and standards in terms of its design and construction:

- EC Low Voltage Directive (2006/95/EC),
- EC EMC Directive (2004/108/EC),

This declaration shall become null and void in the event of unauthorised modifications, improperly conducted repairs, non-observance of the deadlines for the repetition test and / or non-permitted conversion work not specifically authorised by the manufacturer.

The original copy of the declaration of conformity is enclosed with the unit.

3.1.3 Welding in environments with increased electrical hazards



In compliance with IEC / DIN EN 60974, VDE 0544 the machines can be used in environments with an increased electrical hazard.

3.1.4 Service documents (spare parts and circuit diagrams)

DANGER



Do not carry out any unauthorised repairs or modifications!

To avoid injury and equipment damage, the unit must only be repaired or modified by specialist, skilled persons!

The warranty becomes null and void in the event of unauthorised interference.

- Appoint only skilled persons for repair work (trained service personnel)!

Original copies of the circuit diagrams are enclosed with the unit.

Spare parts can be obtained from the relevant authorised dealer.

3.1.5 Calibration/Validation

We hereby confirm that this machine has been tested using calibrated measuring equipment, as stipulated in IEC/EN 60974, ISO/EN 17662, EN 50504, and complies with the admissible tolerances.

Recommended calibration interval: 12 months

4 Machine description – quick overview

 *The device configuration shown may differ in case of an additional ex works options or retrofitting options- See 9 Accessories chapter.*

4.1 Front view

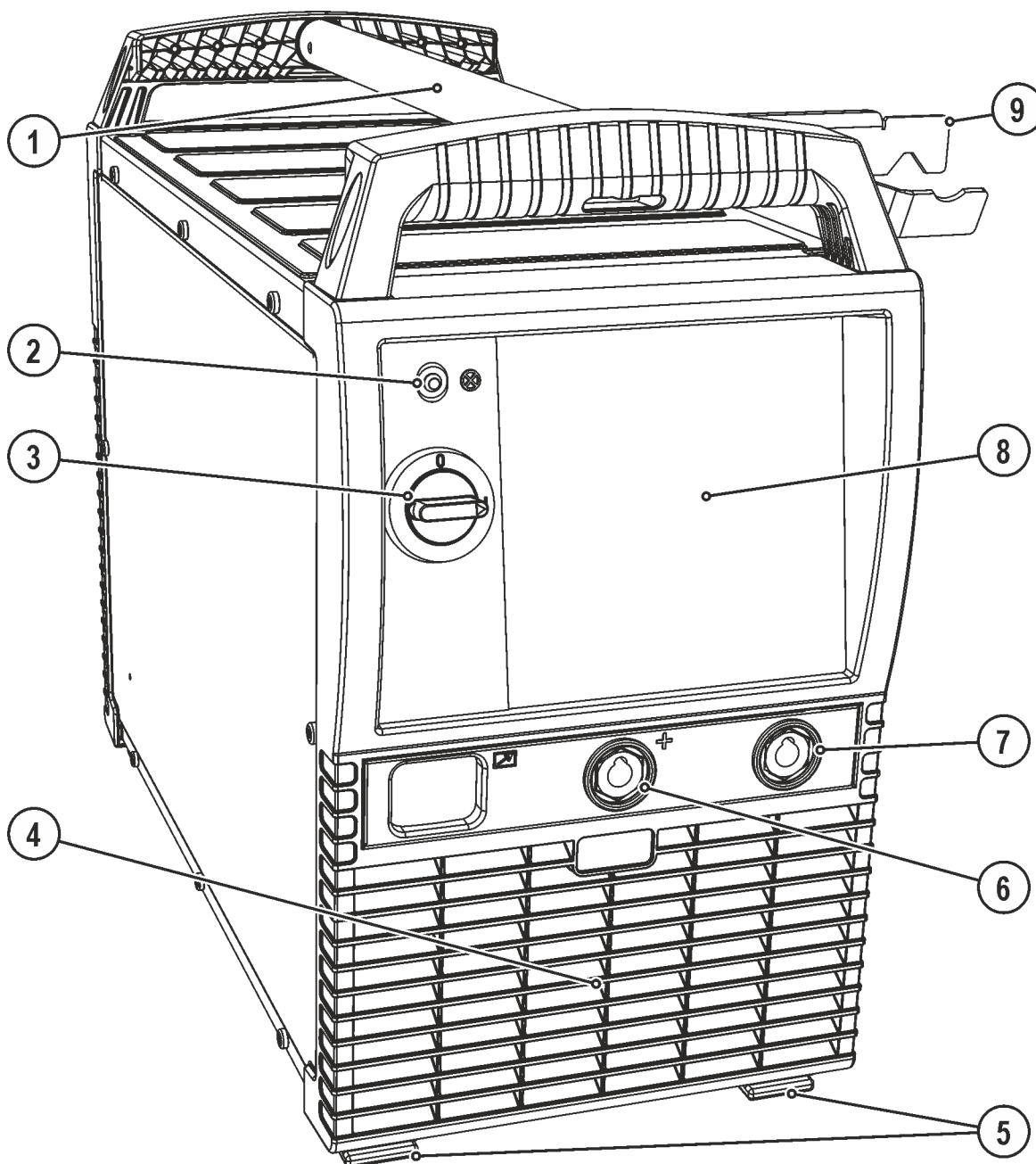





Figure 4-1

Item	Symbol	Description
1		Carrying handle
2		Ready for operation signal light Signal light on when the machine is switched on and ready for operation
3		Main switch, machine on/off
4		Cooling air inlet
5		Machine feet
6		Connection socket, "+" welding current <ul style="list-style-type: none"> • MIG/MAG cored wire welding: Workpiece connection • TIG welding: Workpiece connection • MMA welding: Workpiece connection
7		"-" welding current connection socket <ul style="list-style-type: none"> • MIG/MAG welding: Workpiece connection • MMA welding: electrode holder connection
8		Machine control, see the relevant control operating instructions
9		Torch holder

4.2 Rear view

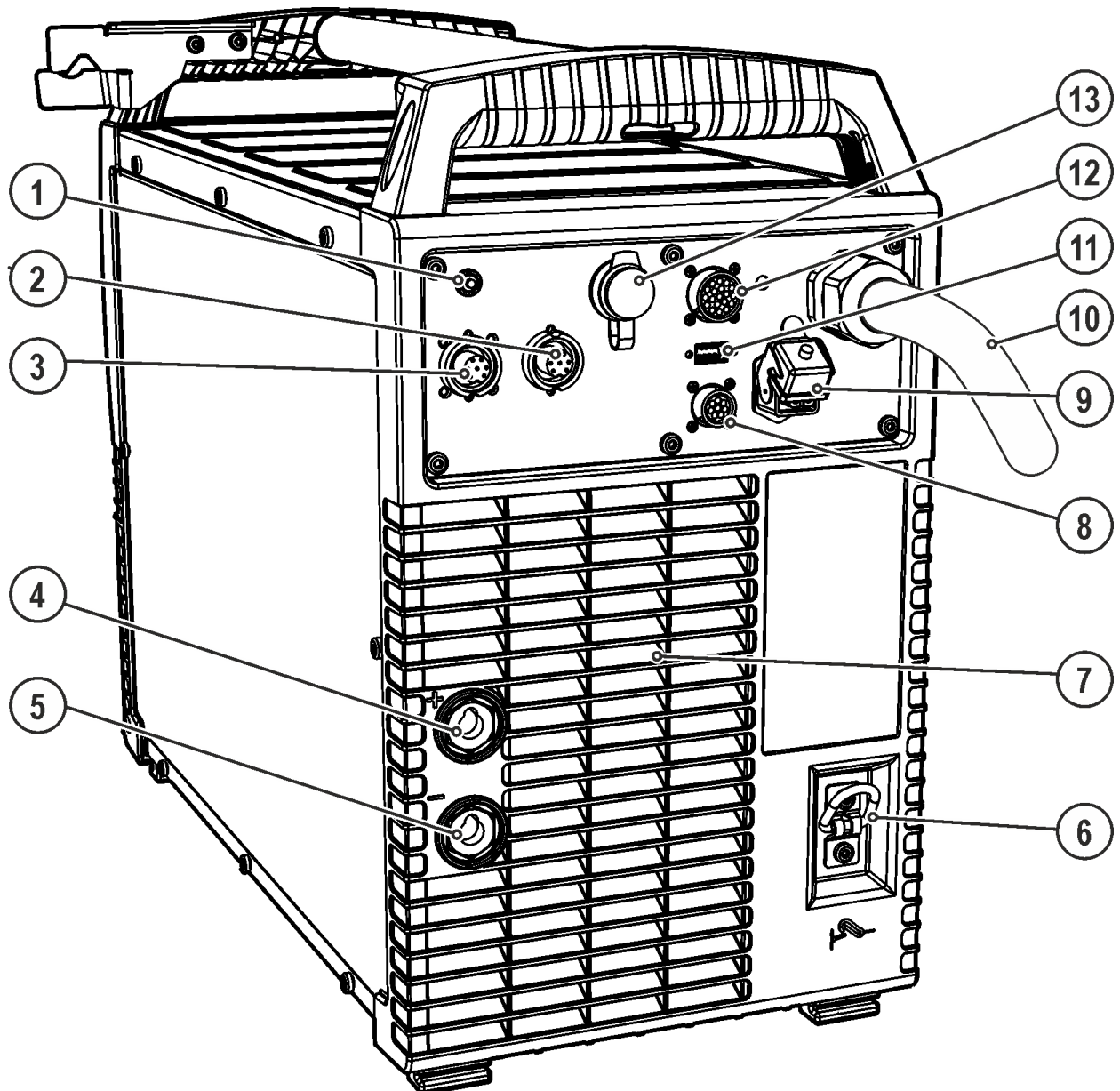
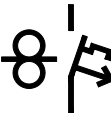









Figure 4-2

Item	Symbol	Description
1		Key button, Automatic cutout Wire feed motor supply voltage fuse (press to reset a triggered fuse)
2		Connection socket, 7-pole Connection for peripheral devices with digital interface
3		7-pole connection socket (digital) Wire feed unit connection
4		Connection socket, “+” welding current • Standard MIG/MAG welding (intermediate hose package)
5		Connection socket, “-” welding current Connection for welding current plug from intermediate hose package • MIG/MAG flux cored wire welding • TIG welding
6		Stirrup Intermediate hose package strain relief
7		Cooling air outlet
8		8-pole connection socket Cooling unit control lead
9		4-pole connection socket Cooling unit voltage supply
10		Mains connection cable - See 5.5 Mains connection chapter
11		PC interface, serial (D-Sub connection socket, 9-pole)
12	 analog	19-pole mechanised welding interface (analogue) - See 7.2.1 Interface for automated welding chapter
13		LAN interface

5 Design and function

5.1 General

WARNING



Risk of injury from electric shock!

Contact with live parts, e.g. welding current sockets, is potentially fatal!

- Follow safety instructions on the opening pages of the operating instructions.
- Commissioning may only be carried out by persons who have the relevant expertise of working with arc welding machines!
- Connection and welding leads (e.g. electrode holder, welding torch, workpiece lead, interfaces) may only be connected when the machine is switched off!

CAUTION



Insulate the arc welder from welding voltage!

Not all active parts of the welding current circuit can be shielded from direct contact. To avoid any associated risks it is vital for the welder to adhere to the relevant safety regulations. Even low voltages can cause a shock and lead to accidents.

- Wear dry and undamaged protective clothing (shoes with rubber soles/welder's gloves made from leather without any studs or braces)!
- Avoid direct contact with non-insulated connection sockets or connectors!
- Always place torches and electrode holders on an insulated surface!



Risk of burns on the welding current connection!

If the welding current connections are not locked, connections and leads heat up and can cause burns, if touched!

- Check the welding current connections every day and lock by turning in clockwise direction, if necessary.



Risk from electrical current!

If welding is carried out alternately using different methods and if a welding torch and an electrode holder remain connected to the machine, the open-circuit/welding voltage is applied simultaneously on all cables.

- The torch and the electrode holder should therefore always be placed on an insulated surface before starting work and during breaks.

CAUTION**Damage due to incorrect connection!**

Accessory components and the power source itself can be damaged by incorrect connection!

- Only insert and lock accessory components into the relevant connection socket when the machine is switched off.
- Comprehensive descriptions can be found in the operating instructions for the relevant accessory components.
- Accessory components are detected automatically after the power source is switched on.

**Using protective dust caps!**

Protective dust caps protect the connection sockets and therefore the machine against dirt and damage.

- The protective dust cap must be fitted if there is no accessory component being operated on that connection.
- The cap must be replaced if faulty or if lost!



Observe documentation of other system components when connecting!

5.2 Transport and installation

WARNING



**Risk of accident due to improper transport of machines that may not be lifted!
Do not lift or suspend the machine! The machine can fall down and cause injuries! The handles and brackets are suitable for transport by hand only!**

- The machine may not be lifted by crane or suspended!
- Depending on machine type, equipment for lifting by crane or use while suspended is available as a retrofitting option - See 9 Accessories chapter.

CAUTION



Installation site!

The machine must not be operated in the open air and must only be set up and operated on a suitable, stable and level base!

- The operator must ensure that the ground is non-slip and level, and provide sufficient lighting for the place of work.
- Safe operation of the machine must be guaranteed at all times.

5.3 Machine cooling

To obtain an optimal duty cycle from the power components, the following precautions should be observed:

- Ensure that the working area is adequately ventilated.
- Do not obstruct the air inlets and outlets of the machine.
- Do not allow metal parts, dust or other objects to get into the machine.

5.4 Workpiece lead, general

CAUTION



Risk of burns due to incorrect connection of the workpiece lead!

Paint, rust and dirt on the connection restrict the power flow and may lead to stray welding currents.

Stray welding currents may cause fires and injuries!

- Clean the connections!
- Fix the workpiece lead securely!
- Do not use structural parts of the workpiece as a return lead for the welding current!
- Take care to ensure faultless power connections!

5.5 Mains connection

DANGER



Hazard caused by improper mains connection!

An improper mains connection can cause injuries or damage property!

- Only use machine with a plug socket that has a correctly fitted protective conductor.
- If a mains plug must be fitted, this may only be carried out by an electrician in accordance with the relevant national provisions or regulations!
- Mains plug, socket and lead must be checked regularly by an electrician!
- When operating the generator always ensure it is earthed as stated in the operating instructions. The resulting network has to be suitable for operating devices according to protection class 1.

5.5.1 Mains configuration



The machine may be connected to:

- a three-phase system with four conductors and an earthed neutral conductor
- a three-phase system with three conductors of which any one can be earthed, e.g. the outer conductor

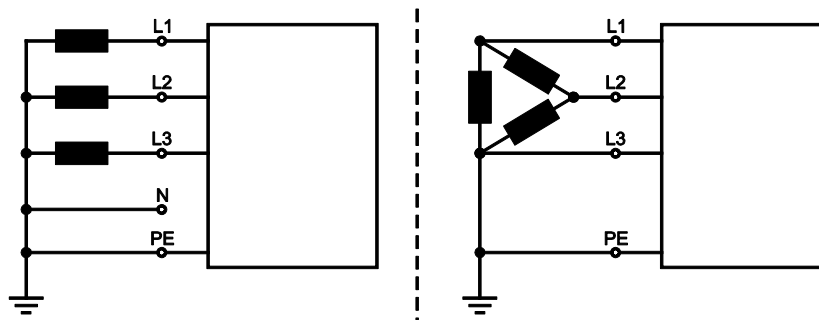

Figure 5-1

Legend

Item	Designation	Colour code
L1	Outer conductor 1	brown
L2	Outer conductor 2	black
L3	Outer conductor 3	grey
N	Neutral conductor	blue
PE	Protective conductor	green-yellow

CAUTION



Operating voltage - mains voltage!

The operating voltage shown on the rating plate must be consistent with the mains voltage, in order to avoid damage to the machine!

- - See 8 Technical data chapter!

- Insert mains plug of the switched-off machine into the appropriate socket.

5.6 Notes on the installation of welding current leads

- ✎ *Incorrectly installed welding current leads can cause faults in the arc (flickering).*
- ✎ *Lay the workpiece lead and hose package of power sources without HF igniter (MIG/MAG) for as long and as close as possible in parallel.*
- ✎ *Lay the workpiece lead and hose package of power sources with HF igniter (TIG) for as long as possible in parallel with a distance of 20 cm to avoid HF sparkover.*
- ✎ *Always keep a distance of at least 20 cm to leads of other power sources to avoid interferences*
- ✎ *Always keep leads as short as possible! For optimum welding results max. 30 m (welding lead + intermediate hose package + torch lead).*

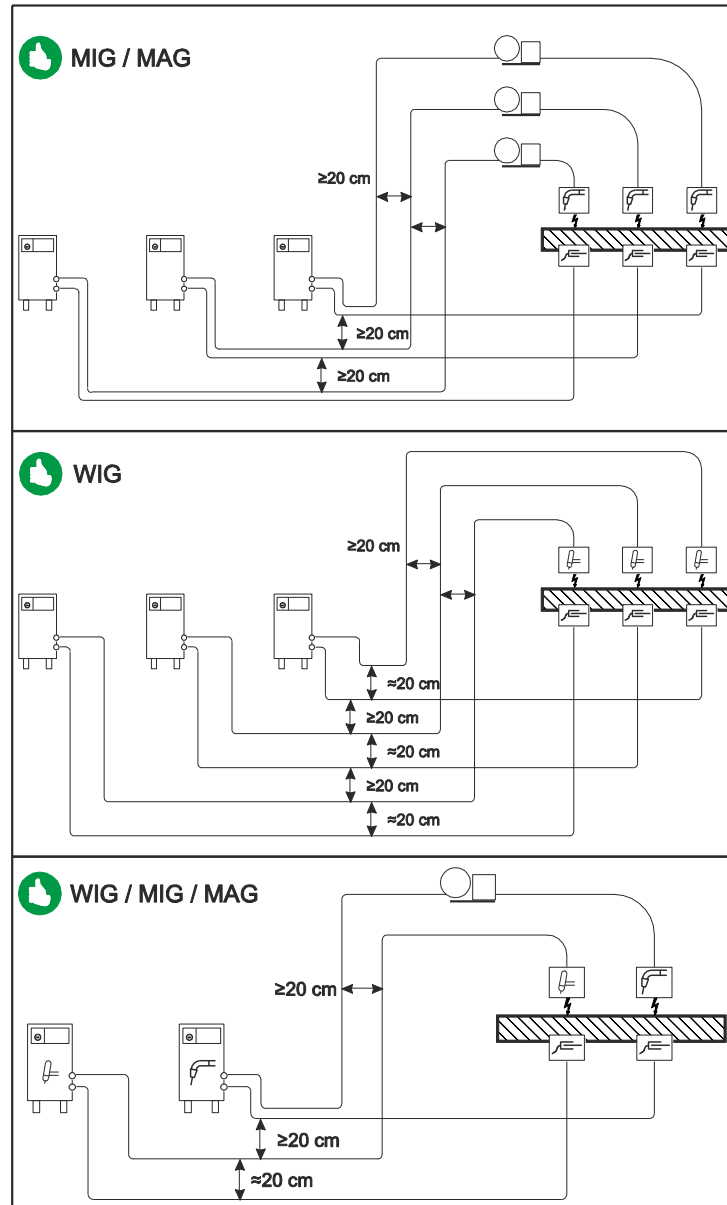

Figure 5-2

Use an individual welding lead to the workpiece for each welding machine!

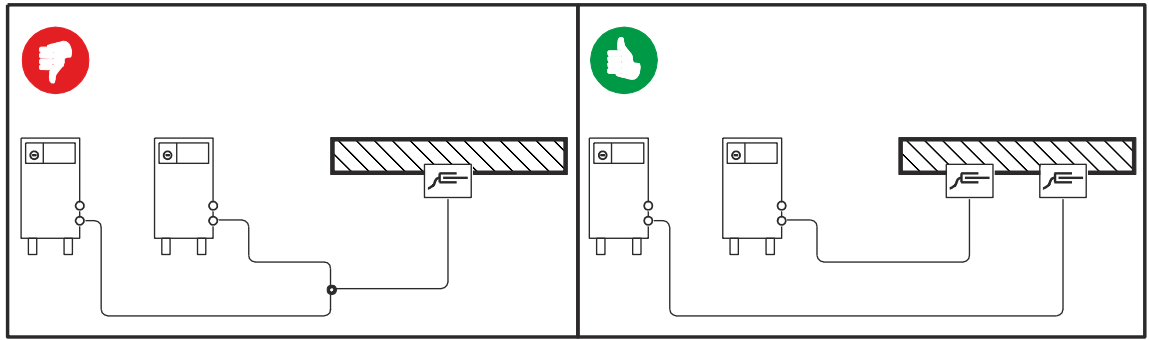

Figure 5-3

Fully unroll welding current leads, torch hose packages and intermediate hose packages. Avoid loops!

Always keep leads as short as possible!

Lay any excess cable lengths in meanders.

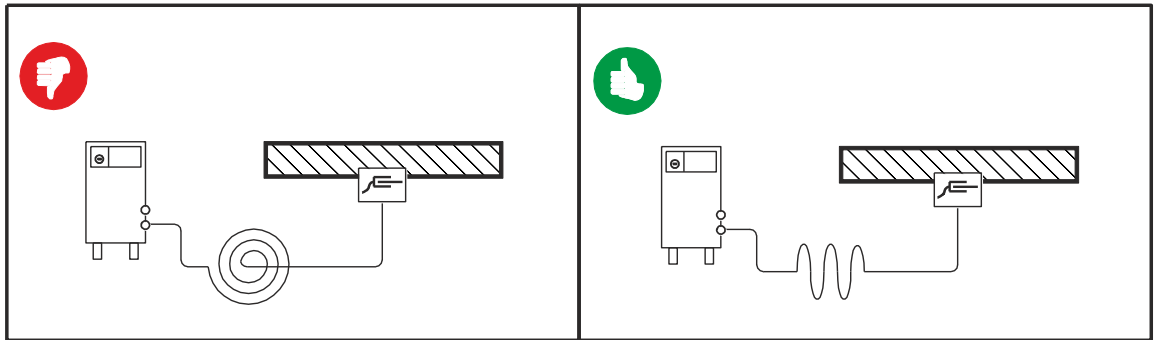

Figure 5-4

5.7 Welding torch cooling system

CAUTION



Coolant mixtures!

Mixtures with other liquids or the use of unsuitable coolants result in material damage and renders the manufacturer's warranty void!

- Only use the coolant described in this manual (overview of coolants).
- Do not mix different coolants.
- When changing the coolant, the entire volume of liquid must be changed.



Insufficient frost protection in the welding torch coolant!

Depending on the ambient conditions, different liquids are used for cooling the welding torch - See 5.7.1 List of coolants chapter.

Coolants with frost protection (KF 37E or KF 23E) must be checked regularly to ensure that the frost protection is adequate to prevent damage to the machine or the accessory components.

- The coolant must be checked for adequate frost protection with the TYP 1 frost protection tester .
- Replace coolant as necessary if frost protection is inadequate!



**The disposal of coolant must be carried out according to official regulations and observing the relevant safety data sheets (German waste code number: 70104)!
Coolant must not be disposed of together with household waste.
Coolant must not be discharged into the sewerage system.
Recommended cleaning agent: water, if necessary with cleaning agent added.**

5.7.1 List of coolants

The following coolants may be used - See 9 Accessories chapter:

Coolant	Temperature range
KF 23E (Standard)	-10 °C to +40 °C
KF 37E	-20 °C to +10 °C

5.7.2 Maximal hose package length

	Pump 3.5 bar	Pump 4.5 bar
Machines with or without separate wire feeder	30 m	60 m
Compact machines with additional intermediate drive (example. miniDrive)	20 m	30 m
Machines with separate wire feeder and additional intermediate drive (example: miniDrive)	20 m	60 m

Data as a rule refer to the entire hose package length

including welding torch. The pump output is shown on the type plate (parameter: Pmax).

Pump 3.5 bar: Pmax = 0.35 MPa (3.5 bar)

Pump 4.5 bar: Pmax = 0.45 MPa (4.5 bar)

5.7.3 Cooling module connection

 Please note the relevant documentation of the accessory components.

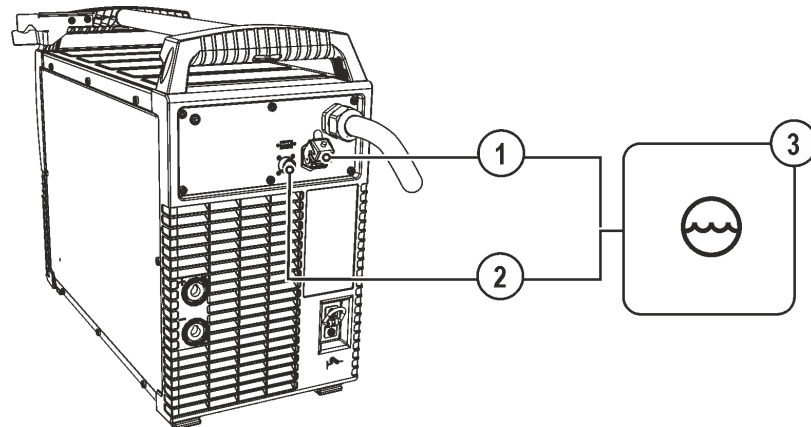





Figure 5-5

Item	Symbol	Description
1		4-pole connection socket Cooling unit voltage supply
2		8-pole connection socket Cooling unit control lead
3		Cooling module

- Insert and lock the 8-pole control lead plug on the cooling unit into the 8-pole connection socket on the welding machine.
- Insert and lock the 4-pole supply plug on the cooling unit into the 4-pole connection socket on the welding machine.

5.8 Aligning the cable resistance

Menu navigation:

System

Cable resistance alignment

Resistance value of the welding leads to optimise the welding properties.

The resistance value of cables can either be set directly or it can be aligned using the power source. The factory setting of the power sources is 8 mΩ. This value corresponds to a 5 m earth cable, a 1.5 m intermediate hose package and a 3 m water-cooled welding torch. With other hose package lengths, it is necessary to carry out a +/- voltage correction to optimise welding properties. The voltage correction value can be set close to zero by means of realigning the cable resistance. It is recommended to align the electric cable resistance after replacing accessories such as torches or intermediate hose packages.

In case a second wire feeder is used the (rL2) parameter has to be aligned. For all other configurations it is sufficient to align the (rL1) parameter.

1 Preparation

- Switch off the welding machine.
- Unscrew the gas nozzle from the welding torch.
- Trim the welding wire so that it is flush with the contact tip.
- Retract the welding wire a little (approx. 50 mm) on the wire feeder. There should now be no more welding wire in the contact tip.

2 Configuration

- Switch on the welding machine.
- Press the "System" push-button.
- Select the "Cable resistance alignment" parameter using the main control button. Parameter RL1 must be aligned for all machine combinations. In case of welding systems with a second power circuit – if two wire feeders are to be operated from a single power source, for example – a second alignment with parameter RL2 must be performed. To activate the required wire feeder for measurement briefly activate (tap) the torch trigger of this machine.

3 Alignment/Measurement

- Press the "D" push-button.
- Applying slight pressure, put the welding torch with the contact tip against a clean, purged location on the workpiece and then press the torch trigger for approx. 2 seconds. A short-circuit current will flow briefly, which is used to determine and display the cable resistance. The value can be between 0 mΩ and 40 mΩ. The new value is immediately saved without requiring further confirmation. If no value is shown on the display, then measurement failed. The measurement must be repeated.
- Press the "A" push-button once the measurement has been successful.

4 Restoring welding standby mode

- Switch off the welding machine.
- Screw the gas nozzle onto the welding torch.
- Switch on the welding machine
- Insert the welding wire.

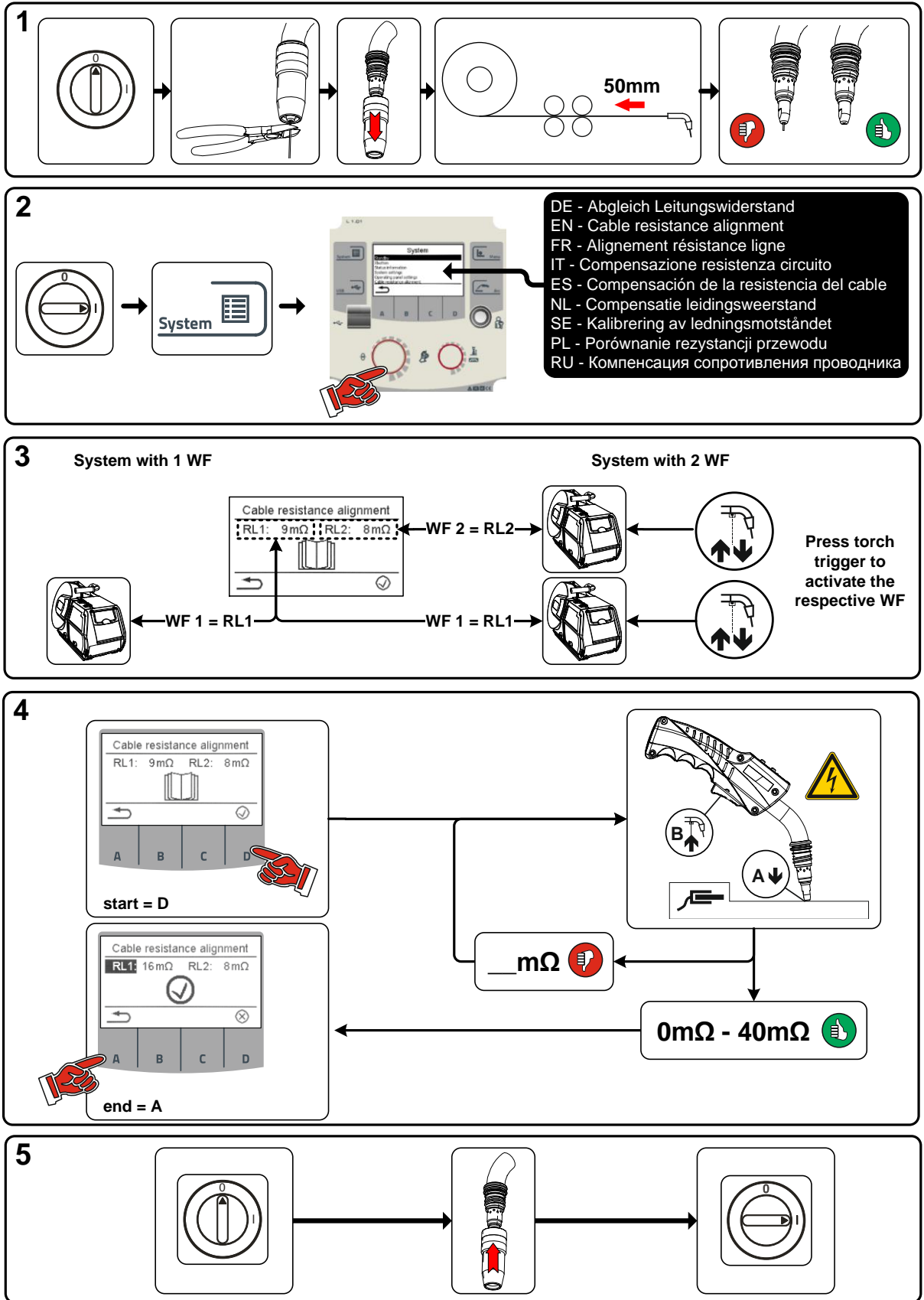

Figure 5-6

5.9 Connecting the intermediate hose package to the power source

5.9.1 Intermediate hose package strain relief

CAUTION



Missing or incorrectly fitted strain relief!

Connection sockets or connection plugs on the machine, or the intermediate tube package, may be damaged if the strain relief is missing or incorrectly fitted. The strain relief takes the strain from cables, plugs and sockets.

- Check the strain relief function by pulling in all directions. Cables and hoses must have sufficient play when the relief cord is fully stretched!

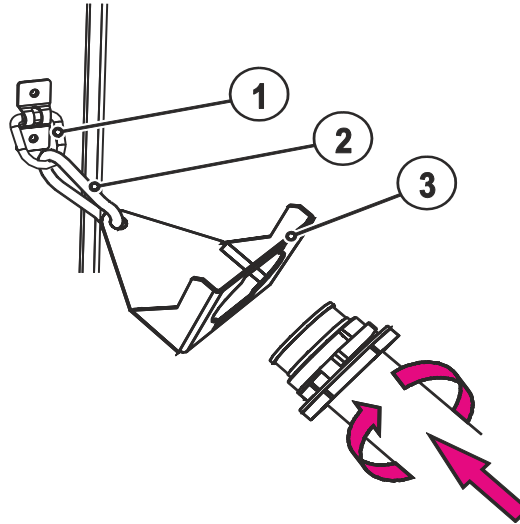

Figure 5-7

Item	Symbol	Description
1		Stirrup Intermediate hose package strain relief
2		Snap hooks
3		Intermediate hose package strain relief

- Insert the end of the hose package through the strain relief of the hose package and lock by turning to the right.

5.9.2 Intermediate hose package connection



Some wire electrodes (e.g. self-shielding cored wire) are welded using negative polarity. In this case, the welding current lead should be connected to the "-" welding current socket, and the workpiece lead should be connected to the "+" welding current socket. Observe the information from the electrode manufacturer!

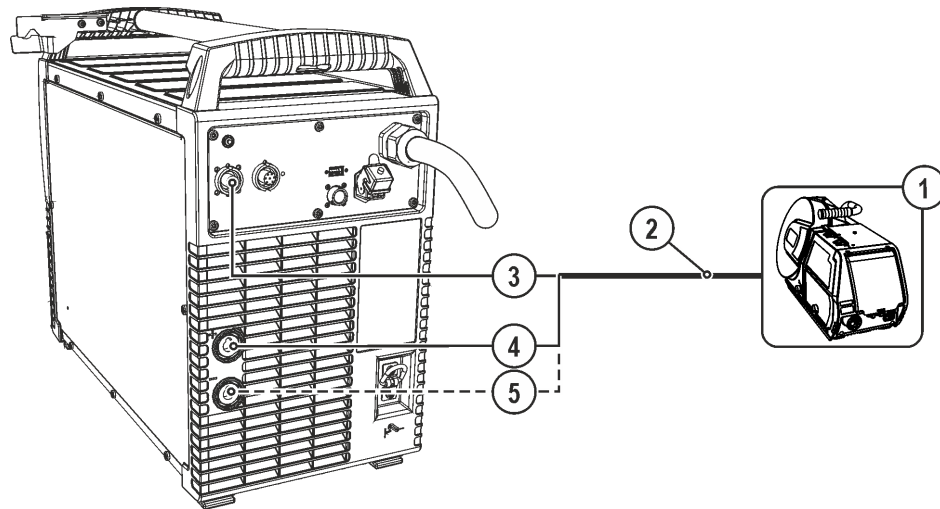

Figure 5-8

Item	Symbol	Description
1		Wire feed unit
2		Intermediate hose package
3		7-pole connection socket (digital) Wire feed unit connection
4		Connection socket, "+" welding current • Standard MIG/MAG welding (intermediate hose package)
5		Connection socket, "-" welding current Connection for welding current plug from intermediate hose package • MIG/MAG flux cored wire welding • TIG welding

- Insert the end of the hose package through the strain relief of the hose package and lock by turning to the right.
- Insert the plug of the welding current lead into the welding current connection socket and lock in place by turning to the right.
- Insert cable plug on the control lead into the 7-pole connection socket and secure with crown nut (the plug can only be inserted into the connection socket in one position).

5.9.3 Shielding gas supply (shielding gas cylinder for welding machine)

WARNING

Risk of injury due to improper handling of shielding gas cylinders! Improper handling and insufficient securing of shielding gas cylinders can cause serious injuries!

- The fastening elements must tightly enclose the shielding gas cylinder!
- Attach the fastening elements within the upper half of the shielding gas cylinder!
- Do not attach any element to the shielding gas cylinder valve!
- Observe the instructions from the gas manufacturer and any relevant regulations concerning the use of compressed air!
- Avoid heating the shielding gas cylinder!

CAUTION

Faults in the shielding gas supply.
An unhindered shielding gas supply from the shielding gas cylinder to the welding torch is a fundamental requirement for optimum welding results. In addition, a blocked shielding gas supply may result in the welding torch being destroyed.

- Always re-fit the yellow protective cap when not using the shielding gas connection.
- All shielding gas connections must be gas tight.

Before connecting the pressure regulator to the gas cylinder, open the cylinder valve briefly to expel any dirt.

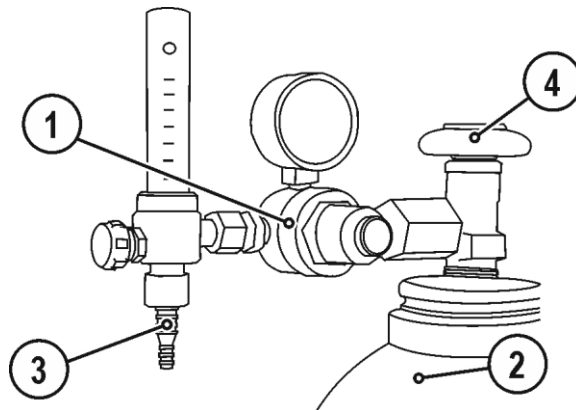

Figure 5-9

Item	Symbol	Description
1		Pressure regulator
2		Shielding gas cylinder
3		Output side of the pressure regulator
4		Cylinder valve

- Place the shielding gas cylinder into the relevant cylinder bracket.
- Secure the shielding gas cylinder using a securing chain.
- Tighten the pressure regulator screw connection on the gas bottle valve to be gas-tight.
- Screw the gas hose (intermediate hose package) to the pressure regulator ensuring that it is gas tight.

5.10 Welding torch holder

The item described in the following is part of the machine's scope of delivery.

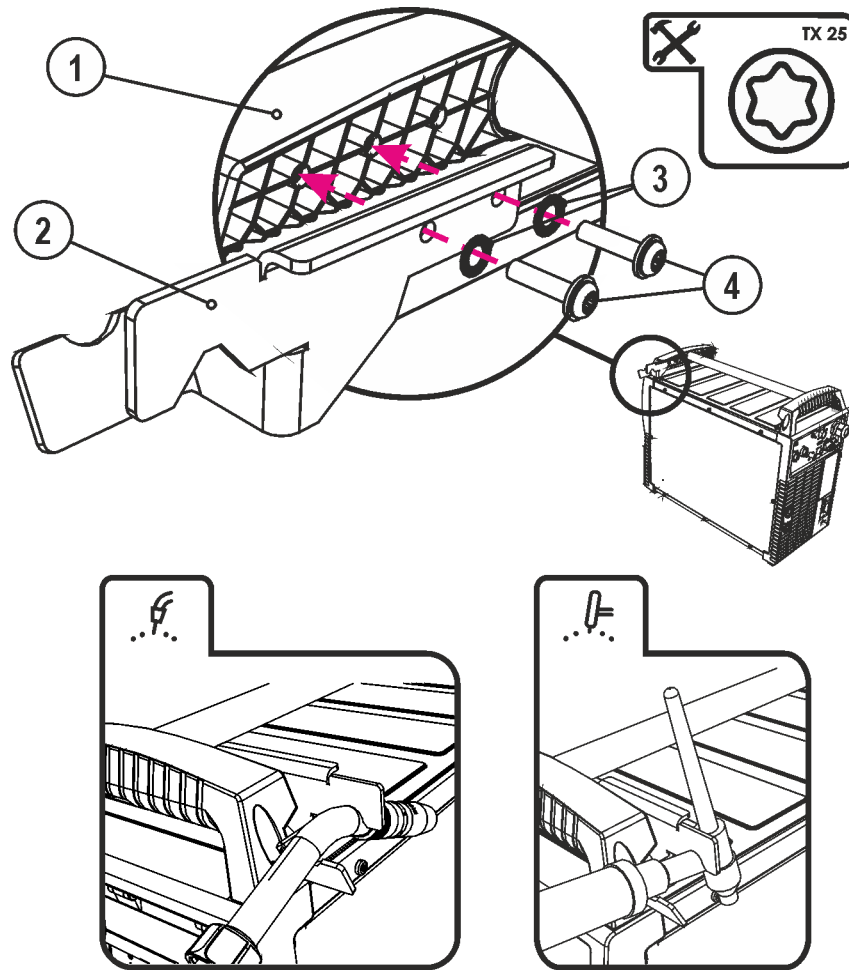

Figure 5-10

Item	Symbol	Description
1		Crossmember of the transport handle
2		Torch holder
3		Fan-type lock washers
4		Fixing screws (x 4)

- Use the mounting screws to screw the torch holder onto the crossmember of the transport handle.
- Insert the welding torch into the welding torch holder as shown.

5.11 MIG/MAG welding

5.11.1 Connection for workpiece lead



Some wire electrodes (e.g. self-shielding cored wire) are welded using negative polarity. In this case, the welding current lead should be connected to the "-" welding current socket, and the workpiece lead should be connected to the "+" welding current socket. Observe the information from the electrode manufacturer!

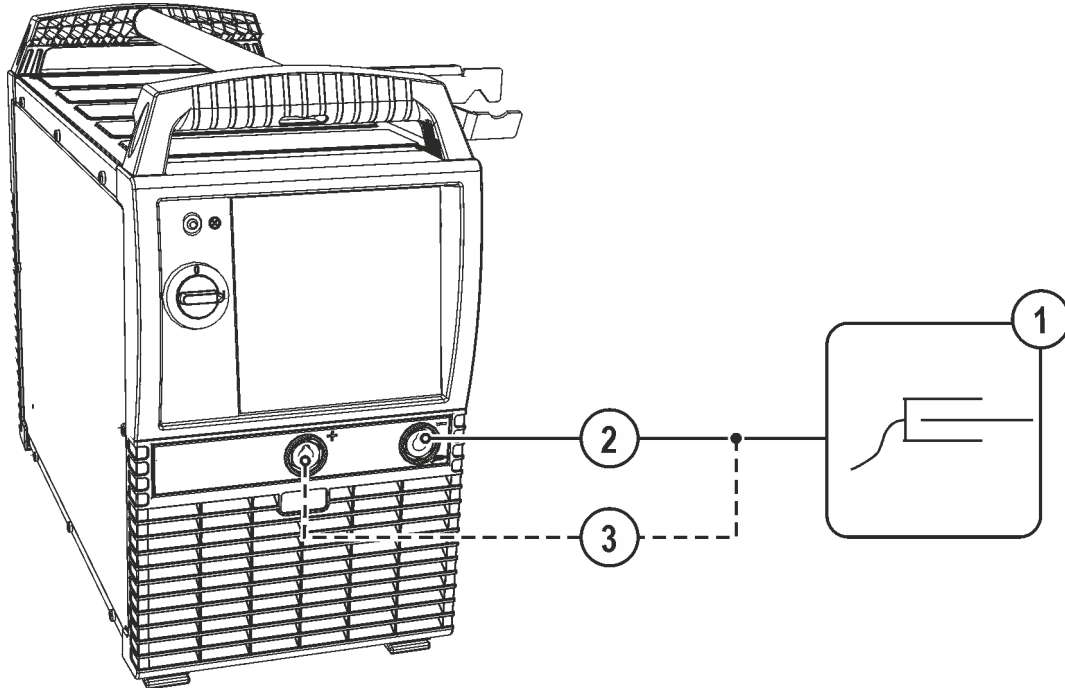



Figure 5-11

Item	Symbol	Description
1		Workpiece
2		"-" welding current connection socket • MIG/MAG welding: Workpiece connection
3		Connection socket, "+" welding current • MIG/MAG cored wire welding: Workpiece connection

- Insert the plug on the workpiece lead into the "-" welding current connection socket and lock.

5.12 TIG welding

5.12.1 Welding torch connection

-  *The welding torch is connected to the wire feeder.
Observe the operating instructions for the wire feeder (system component)!*

5.12.2 Connection for workpiece lead

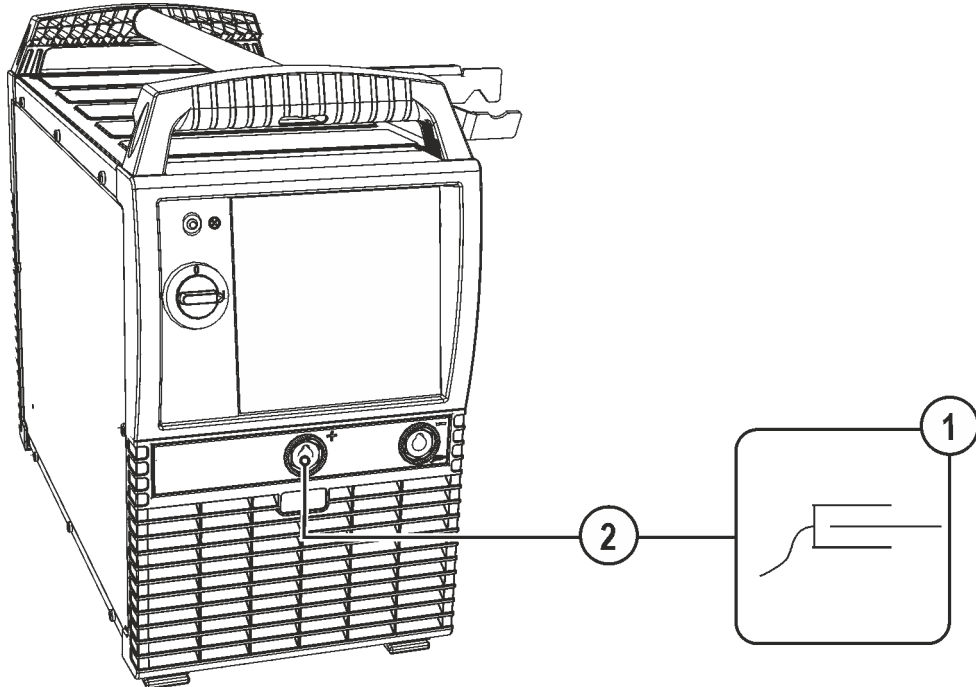



Figure 5-12

Item	Symbol	Description
1		Workpiece
2		Connection socket, "+" welding current • TIG welding: Workpiece connection

- Insert the plug on the welding current lead into the welding current connection socket "+" and lock.

5.13 MMA welding

⚠ CAUTION



Risk of being crushed or burnt.

When replacing spent or new stick electrodes

- Switch off machine at the main switch
- Wear appropriate safety gloves
- Use insulated tongs to remove spent stick electrodes or to move welded workpieces and
- Always put the electrode holder down on an insulated surface.

5.13.1 Connecting the electrode holder and workpiece lead

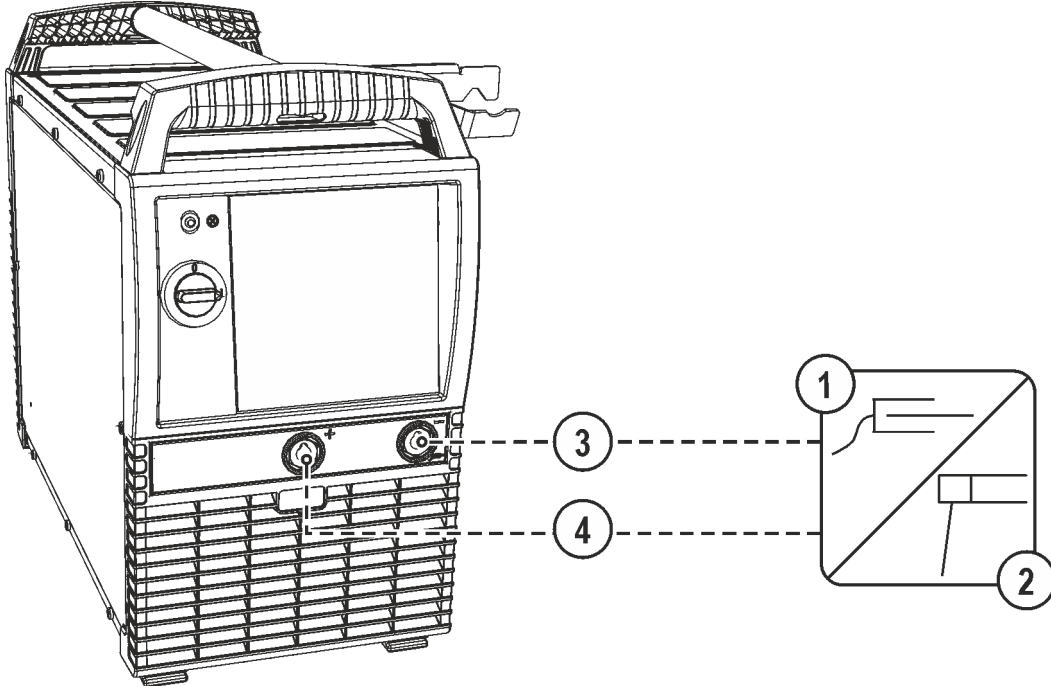

Figure 5-13

Item	Symbol	Description
1		Workpiece
2		Electrode holder
3		Connection socket, "-" welding current
4		Connection socket, "+" welding current

- Insert cable plug of the electrode holder into either the "+" or "-" welding current connection socket and lock by turning to the right.
- Insert cable plug of the workpiece lead into either the "+" or "-" welding current connection socket and lock by turning to the right.



Polarity depends on the instructions from the electrode manufacturer given on the electrode packaging.

5.14 Remote control

CAUTION



Damage due to the use of non-genuine parts!

The manufacturer's warranty becomes void if non-genuine parts are used!

- Only use system components and options (power sources, welding torches, electrode holders, remote controls, spare parts and replacement parts, etc.) from our range of products!
- Only insert and lock accessory components into the relevant connection socket when the machine is switched off.



The remote controls are operated on the 7-pole remote control connection socket (digital).



Please note the relevant documentation of the accessory components.

5.15 Interfaces



DANGER



Do not carry out any unauthorised repairs or modifications!

To avoid injury and equipment damage, the unit must only be repaired or modified by specialist, skilled persons!

The warranty becomes null and void in the event of unauthorised interference.

- Appoint only skilled persons for repair work (trained service personnel)!

CAUTION



Damage due to incorrect connection!

Accessory components and the power source itself can be damaged by incorrect connection!

- Only insert and lock accessory components into the relevant connection socket when the machine is switched off.
- Comprehensive descriptions can be found in the operating instructions for the relevant accessory components.
- Accessory components are detected automatically after the power source is switched on.

5.15.1 Automation interface

These accessory components can be retrofitted as an option - See 9 Accessories chapter.

Pin	Input / output	Description	Diagram
A	Output	PE Connection for cable shielding	
D	Output (open collector)	IGRO Current flows signal I>0 (maximum load 20 mA / 15 V) 0 V = welding current flows	
E + R	Input	Not/Aus Emergency stop for higher level shut-down of the power source. To use this function, jumper 1 must be unplugged on PCB M320/1 in the welding machine. Contact open = welding current off	
F	Output	0 V Reference potential	
G/P	Output	I>0 Power relay contact, galvanically isolated (max. +/-15 V / 100 mA)	
H	Output	Uist Welding voltage, measured against pin F, 0-10 V (0 V = 0 V; 10 V = 100 V)	
L	Input	Str/Stp Start = 15 V / Stop = 0 V ¹⁾	
M	Output	+15 V Voltage supply (max. 75 mA)	
N	Output	-15 V Voltage supply (max. 25 mA)	
S	Output	0 V Reference potential	
T	Output	list Welding current, measured on pin F; 0-10 V (0 V = 0 A, 10 V = 1000 A)	

¹⁾ The operating mode is given by the wire feed unit (the start / stop function equates to pressing the torch trigger and is used in mechanised applications, for example).

5.15.2 RINT X12 robot interface

The standard digital interface for mechanised applications
(optional, retrofitting on the machine or external fitting by the customer)

Functions and signals:

- Digital inputs: start/stop, operating modes, JOB and program selection, inching, gas test
- Analogue inputs: control voltages, e.g. for welding performance, welding current, etc.
- Relay outputs: process signal, ready for welding, system composite fault, etc.

5.15.3 BUSINT X11 Industrial bus interface

The solution for easy integration with automated production with e.g.

- Profinet/Profibus
- EnthernetIP/DeviceNet
- EtherCAT

etc.

5.16 PC Interfaces

CAUTION



Damage due to the use of non-genuine parts!

The manufacturer's warranty becomes void if non-genuine parts are used!

- Only use system components and options (power sources, welding torches, electrode holders, remote controls, spare parts and replacement parts, etc.) from our range of products!
- Only insert and lock accessory components into the relevant connection socket when the machine is switched off.



Equipment damage or faults may occur if the PC is connected incorrectly!

Not using the SECINT X10USB interface results in equipment damage or faults in signal transmission. The PC may be destroyed due to high frequency ignition pulses.

- Interface SECINT X10USB must be connected between the PC and the welding machine!
- The connection must only be made using the cables supplied (do not use any additional extension cables)!



Please note the relevant documentation of the accessory components.

PC 300 welding parameter software

Create all welding parameters quickly on the PC and easily transfer them to one or more welding machines (accessories: set consisting of software, interface, connection leads).

Q-DOC 9000 welding data documentation software

(Accessories: set consisting of software, interface, connection leads)

The ideal tool for welding data documentation of, for example:
welding voltage and current, wire speed and motor current.

WELDQAS welding data monitoring and documentation system

Network-compatible welding data monitoring and documentation system for digital machines

6 Maintenance, care and disposal



Improper maintenance and testing

The equipment may only be cleaned, repaired or tested by specialist, skilled persons! A skilled person is one who, due to training, knowledge and experience, is able to recognise the dangers that can occur during testing of this equipment as well as possible subsequent damage and who is able to implement the required safety procedures.

- Complete all tests given in the chapter below!
- Only put the equipment back into operation following a successful test.



Risk of injury from electric shock!

Cleaning machines that are not disconnected from the mains can lead to serious injuries!

- Disconnect the machine completely from the mains.
- Remove the mains plug!
- Wait for 4 minutes until the capacitors have discharged!

Repair and maintenance work may only be performed by qualified authorised personnel; otherwise the right to claim under warranty is void. In all service matters, always consult the dealer who supplied the machine. Return deliveries of defective equipment subject to warranty may only be made through your dealer. When replacing parts, use only original spare parts. When ordering spare parts, please quote the machine type, serial number and item number of the machine, as well as the type designation and item number of the spare part.

6.1 General

When used in the specified environmental conditions and under normal operating conditions, this machine is largely maintenance-free and requires a minimum of care.

There are some points, which should be observed, to guarantee fault-free operation of your welding machine. Among these are regular cleaning and checking as described below, depending on the pollution level of the environment and the length of time the unit is in use.

6.2 Maintenance work, intervals

6.2.1 Daily maintenance tasks

- Check that all connections and wearing parts are hand-tight and tighten if necessary.
- Check that all screw and plug connections and replaceable parts are secured correctly, tighten if necessary.
- Remove any spatter.
- Clean the wire feed rollers on a regular basis (depending on the degree of soiling).

6.2.1.1 Visual inspection

- Check hose package and power connections for exterior damage and replace or have repaired by specialist staff as necessary!
- Mains supply lead and its strain relief
- Gas tubes and their switching equipment (solenoid valve)
- Other, general condition

6.2.1.2 Functional test

- Check correct mounting of the wire spool.
- Welding current cables (check that they are fitted correctly and secured)
- Gas cylinder securing elements
- Operating, message, safety and adjustment devices (Functional test)

6.2.2 Monthly maintenance tasks

6.2.2.1 Visual inspection

- Casing damage (front, rear and side walls)
- Wheels and their securing elements
- Transport elements (strap, lifting lugs, handle)
- Check coolant tubes and their connections for impurities

6.2.2.2 Functional test

- Selector switches, command devices, emergency stop devices, voltage reducing devices, message and control lamps
- Check that the wire guide elements (inlet nipple, wire guide tube) are fitted securely.

6.2.3 Annual test (inspection and testing during operation)



The welding machine may only be tested by competent, capable persons! A capable person is one who, because of his training, knowledge and experience, is able to recognise the dangers that can occur while testing welding power sources as well as possible subsequent damage and who is able to implement the required safety procedures.



For more information refer to the "Warranty registration" brochure supplied and our information regarding warranty, maintenance and testing at www.ewm-group.com!

A periodic test according to IEC 60974-4 "Periodic inspection and test" has to be carried out. In addition to the regulations on testing given here, the relevant local laws and regulations must also be observed.

6.3 Disposing of equipment



Proper disposal!

The machine contains valuable raw materials, which should be recycled, and electronic components, which must be disposed of.

- **Do not dispose of in household waste!**
- **Observe the local regulations regarding disposal!**



6.3.1 Manufacturer's declaration to the end user

- According to European provisions (guideline 2002/96/EG of the European Parliament and the Council of January, 27th 2003), used electric and electronic equipment may no longer be placed in unsorted municipal waste. It must be collected separately. The symbol depicting a waste container on wheels indicates that the equipment must be collected separately. This machine is to be placed for disposal or recycling in the waste separation systems provided for this purpose.
- According to German law (law governing the distribution, taking back and environmentally correct disposal of electric and electronic equipment (ElektroG) from 16.03.2005), used machines are to be placed in a collection system separate from unsorted municipal waste. The public waste management utilities (communities) have created collection points at which used equipment from private households can be disposed of free of charge.
- Information about giving back used equipment or about collections can be obtained from the respective municipal administration office.
- EWM participates in an approved waste disposal and recycling system and is registered in the Used Electrical Equipment Register (EAR) under number WEEE DE 57686922.
- In addition to this, returns are also possible throughout Europe via EWM sales partners.

6.4 Meeting the requirements of RoHS

We, EWM AG Mündersbach, hereby confirm that all products supplied by us which are affected by the RoHS Directive, meet the requirements of the RoHS (Directive 2011/65/EU).

7 Rectifying faults

All products are subject to rigorous production checks and final checks. If, despite this, something fails to work at any time, please check the product using the following flowchart. If none of the fault rectification procedures described leads to the correct functioning of the product, please inform your authorised dealer.

7.1 Checklist for rectifying faults



The correct machine equipment for the material and process gas in use is a fundamental requirement for perfect operation!

Legend	Symbol	Description
	↘	Fault/Cause
	✘	Remedy

Coolant error/no coolant flowing

- ↘ Insufficient coolant flow
 - ✘ Check coolant level and refill if necessary
- ↘ Air in the coolant circuit
 - ✘ Vent coolant circuit - See 7.3 Vent coolant circuit chapter

Functional errors

- ↘ Machine control without displaying the signal lights after switching on
 - ✘ Phase failure > check mains connection (fuses)
- ↘ No welding performance
 - ✘ Phase failure > check mains connection (fuses)
- ↘ Various parameters cannot be set
 - ✘ Entry level is blocked, disable access lock
- ↘ Connection problems
 - ✘ Make control lead connections and check that they are fitted correctly.
- ↘ Loose welding current connections
 - ✘ Tighten power connections on the torch and/or on the workpiece
 - ✘ Tighten contact tip correctly

7.2 General operating problems

7.2.1 Interface for automated welding

WARNING



No function of the external interrupt equipment (emergency stop switch)!
If the emergency stop circuit has been set up using an external interrupt equipment connected to the interface for automated welding, the machine must be configured for this setup. If this is not observed, the power source will ignore the external interrupt equipment and will not shut down!

- Remove jumper 1 on the T320/1, M320/1 or M321 PCB!

7.3 Vent coolant circuit

- Coolant tank and quick connect coupling of coolant supply and return are only fitted in machines with water cooling.**
- To vent the cooling system always use the blue coolant connection, which is located as deep as possible inside the system (close to the coolant tank)!**

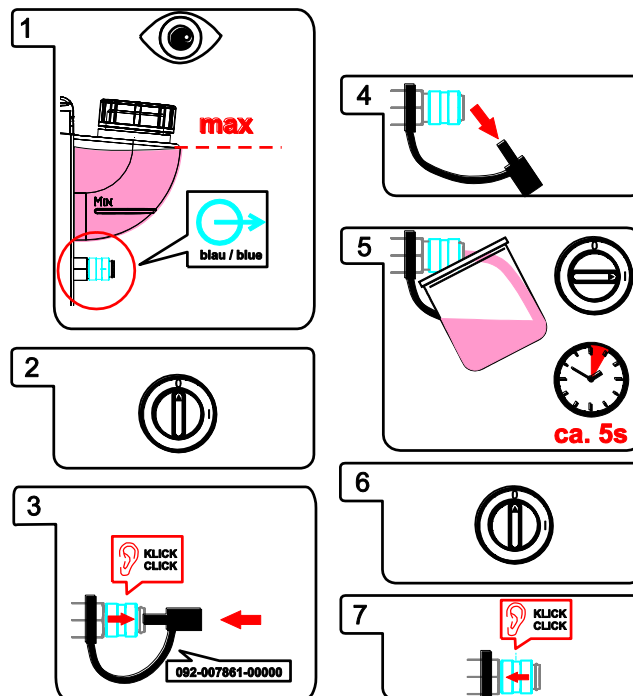

Figure 7-1

8 Technical data





Performance specifications and guarantee only in connection with original spare and replacement parts!

8.1 Phoenix 355 TDM

	TIG	MIG/MAG	MMA
Setting range for welding current	5 A–350 A		
Setting range for welding voltage	10.2 V–24.0 V	14.3 V–31.5 V	20.2 V–34.0 V
Duty cycle	40 °C		
60%	350 A		
100%	300 A		
Load cycle	10 min (60% DC \triangle 6 min welding, 4 min pause)		
Open circuit voltage	79 V		
Mains voltage (tolerances)	3 x 400 V (-25% to +20%)		
Frequency	50/60 Hz		
Mains fuse (safety fuse, slow-blow)	3 x 20 A		
Mains connection lead	H07RN-F4G6		
Max. connected load	10.6 kVA	13.9 kVA	15.0 kVA
Recommended generator rating	20.3 kVA		
cos ϕ /efficiency	0.99/88%		
Insulation class/protection classification	H/IP 23		
Ambient temperature	-25 °C to +40 °C		
Machine/welding torch cooling	Fan/gas		
Workpiece lead	70 mm ²		
Dimensions (L x W x H)	625 mm x 300 mm x 535 mm		
Weight	41 kg		
EMC class	A		
Constructed to standard	IEC 60974-1, -10 ☑ / C E		

8.2 Phoenix 405

	TIG	MIG/MAG	MMA
Setting range for welding current	5 A–400 A		
Setting range for welding voltage	10.2 V–26.0 V	14.3 V–34.0 V	20.2 V–36.0 V
Duty cycle	40 °C		
100%	400 A		
Load cycle	10 min. (60% DC Δ 6 min. welding, 4 min. pause)		
Open circuit voltage	79 V		
Open circuit voltage (VRD)	22 V		
Mains voltage (tolerances)	3 x 400 V (-25% to +20%)		
Frequency	50/60 Hz		
Mains fuse (safety fuse, slow-blow)	3 x 32 A		
Mains connection lead	H07RN-F4G6		
Max. connected load	13.1 kVA	17.2 kVA	18.2 kVA
Recommended generator rating	24.6 kVA		
cosϕ/efficiency	0.99/90%		
Insulation class/protection classification	H/IP 23		
Ambient temperature	-25 °C to +40 °C		
Machine/welding torch cooling	Fan/gas		
Workpiece lead	70 mm ²		
Dimensions (L x W x H)	625 mm x 300 mm x 535 mm		
Weight	41 kg		
EMC class	A		
Constructed to standard	IEC 60974-1, -10 /  / 		

8.3 Phoenix 505

	TIG		MIG/MAG		MMA	
Setting range for welding current	5 A–500 A					
Setting range for welding voltage	10.2 V–30.0 V		14.3 V–39.0 V		20.2 V–40.0 V	
Duty cycle	40 °C	25 °C	40 °C	25 °C	40 °C	25 °C
60%	500 A	-	500 A	-	500 A	-
65%	-	500 A	-	500 A	-	500 A
100%	430 A	460 A	430 A	460 A	430 A	460 A
Load cycle	10 min. (60% DC Δ 6 min. welding, 4 min. pause)					
Open circuit voltage	79 V					
VRD open circuit voltage	22 V					
Mains voltage (tolerances)	3 x 400 V (-25% to +20%)					
Frequency	50/60 Hz					
Mains fuse (safety fuse, slow-blow)	3 x 32 A					
Mains connection lead	H07RN-F4G6					
Max. connected load	18.9 kVA		24.6 kVA		25.2 kVA	
Recommended generator rating	34.0 kVA					
cos ϕ /efficiency	0.99/90%					
Insulation class/protection classification	H/IP 23					
Ambient temperature	-25 °C to +40 °C					
Machine/welding torch cooling	Fan/gas					
Workpiece lead	95 mm ²					
Dimensions (L x W x H)	625 mm x 300 mm x 535 mm					
Weight	45 kg					
EMC class	A					
Constructed to standard	IEC 60974-1, -10 S / CE					

9 Accessories

 *Performance-dependent accessories like torches, workpiece leads, electrode holders or intermediate hose packages are available from your authorised dealer.*

9.1 Wire feed units

Type	Designation	Item no.
drive 4X HP	Wire feeder, water-cooled, Euro torch connector	090-005392-00502
drive 4X HP MMA	Wire feeder, water-cooled, Euro torch connector with connection capability for electrode holder or gouging torch	090-005392-51502
drive 4X LP	Wire feeder, water-cooled, Euro torch connector	090-005412-00502
drive 4X LP MMA	Wire feeder, water-cooled, Euro torch connector	090-005412-51502

9.2 Options

Type	Designation	Item no.
ON Filter 355/405/505/50	Contamination filter for air inlet	092-002698-00000
ON AIF MOD 505	Automation interface	092-007891-00000
ON FC CS 405/505	Pedestal for transport with floor conveyors	092-007896-00000
ON WAK CS 405/505	Wheel assembly kit for CS 505	092-007897-00000

9.3 Welding torch cooling system

Type	Designation	Item no.
cool50-2 U40	Cooling module	090-008603-00502
cool50-2 U42	Cooling unit with reinforced pump	090-008797-00502

9.4 Transport systems

Type	Designation	Item no.
Trolley 39-1	Transport vehicle, power source	090-008708-00000
Trolley 55-5	Transport cart, assembled	090-008632-00000
ON TR Trolley 55-5	Cross arm and holder for wire feeder	092-002700-00000
ON PS Trolley 55-5 drive 4L/4X	Pivot support	092-002712-00000
ON PS Trolley 55-5 drive 200/300C	Pivot support	092-002634-00000

9.5 Remote control / connection cable

9.5.1 7-pole connection

Type	Designation	Item no.
R40 7POL	Remote control, 10 programs	090-008088-00000
R50 7POL	Remote control, all welding machine functions can be set directly at the workplace	090-008776-00000
FRV 7POL 0.5 m	Extension/connecting cable	092-000201-00004
FRV 7POL 5 m	Extension/connecting cable	092-000201-00003
FRV 7POL 10 m	Extension/connecting cable	092-000201-00000
FRV 7POL 20 m	Extension/connecting cable	092-000201-00001
FRV 7POL 25M	Extension/connecting cable	092-000201-00007

9.6 General accessories

Type	Designation	Item no.
5POLE/CEE/32A/M	Machine plug	094-000207-00000
DMDIN TN 200B AR/MIX 35L	Manometer pressure regulator	094-000009-00000

10 Appendix A

10.1 Overview of EWM branches

Headquarters

EWM AG
Dr. Günter-Henle-Straße 8
56271 Mündersbach · Germany
Tel: +49 2680 181-0 · Fax: -244
www.ewm-group.com · info@ewm-group.com

Technology centre

EWM AG
Forststraße 7-13
56271 Mündersbach · Germany
Tel: +49 2680 181-0 · Fax: -144
www.ewm-group.com · info@ewm-group.com



Production, Sales and Service

EWM AG
Dr. Günter-Henle-Straße 8
56271 Mündersbach · Germany
Tel: +49 2680 181-0 · Fax: -244
www.ewm-group.com · info@ewm-group.com

EWM HIGH TECHNOLOGY (Kunshan) Ltd.
10 Yuanshan Road, Kunshan · New & Hi-tech Industry Development Zone
Kunshan City · Jiangsu · Post code 215300 · People's Republic of China
Tel: +86 512 57867-188 · Fax: -182
www.ewm.cn · info@ewm.cn · info@ewm-group.cn

EWM HIGHTEC WELDING s.r.o.
9. května 718 / 31
407 53 Jiřkov · Czech Republic
Tel: +420 412 358-551 · Fax: -504
www.ewm-jirkov.cz · info@ewm-jirkov.cz

Sales and Service Germany

EWM AG
Sales and Technology Centre
Grünauer Fenn 4
14712 Rathenow · Tel: +49 3385 49402-0 · Fax: -20
www.ewm-rathenow.de · info@ewm-rathenow.de

EWM AG
Rudolf-Winkel-Straße 7-9
37079 Göttingen · Tel: +49 551-3070713-0 · Fax: -20
www.ewm-goettingen.de · info@ewm-goettingen.de

EWM AG
Sachsstraße 28
50259 Pulheim · Tel: +49 2234 697-047 · Fax: -048
www.ewm-pulheim.de · info@ewm-pulheim.de

EWM AG
August-Horch-Straße 13a
56070 Koblenz · Tel: +49 261 963754-0 · Fax: -10
www.ewm-koblenz.de · info@ewm-koblenz.de

EWM AG
Eiserfelder Straße 300
57080 Siegen · Tel: +49 271 3878103-0 · Fax: -9
www.ewm-siegen.de · info@ewm-siegen.de

EWM HIGHTEC WELDING GmbH
Sales and Technology Centre
Draisstraße 2a
69469 Weinheim · Tel: +49 6201 84557-0 · Fax: -20
www.ewm-weinheim.de · info@ewm-weinheim.de

EWM Schweißtechnik Handels GmbH
Karlsdorfer Straße 43
88069 Tettngang · Tel: +49 7542 97998-0 · Fax: -29
www.ewm-tettngang.de · info@ewm-tettngang.de

EWM Schweißtechnik Handels GmbH
Heinkelstraße 8
89231 Neu-Ulm · Tel: +49 731 7047939-0 · Fax: -15
www.ewm-neu-ulm.de · info@ewm-neu-ulm.de

Sales and Service International

EWM HIGH TECHNOLOGY (Kunshan) Ltd.
10 Yuanshan Road, Kunshan · New & Hi-tech Industry Development Zone
Kunshan City · Jiangsu · Post code 215300 · People's Republic of China
Tel: +86 512 57867-188 · Fax: -182
www.ewm.cn · info@ewm.cn · info@ewm-group.cn

EWM HIGHTEC WELDING GmbH
Wiesenstraße 27b
4812 Pilsdorf · Austria · Tel: +43 7612 778 02-0 · Fax: -20
www.ewm-austria.at · info@ewm-austria.at

EWM HIGHTEC WELDING UK Ltd.
Unit 2B Coopies Way · Coopies Lane Industrial Estate
Morpeth · Northumberland · NE61 6JN · Great Britain
Tel: +44 1670 505875 · Fax: -514305
www.ewm-morpeth.co.uk · info@ewm-morpeth.co.uk

EWM HIGHTEC WELDING Sales s.r.o. / Prodejní a poradenské centrum
Tyrřova 2106
256 01 Benešov u Prahy · Czech Republic
Tel: +420 317 729-517 · Fax: -712
www.ewm-benesov.cz · info@ewm-benesov.cz

Liaison office Turkey

EWM AG Türkiye İrtibat Bürosu
İktelli OSB Mah. · Marmara Sanayi Sitesi P Blok Apt. No: 44
Küçükçekmece / İstanbul Türkiye
Tel: +90 212 494 32 19
www.ewm-istanbul.com.tr · info@ewm-istanbul.com.tr

