



EN

Intermediate drive unit

**miniDrive GS
miniDrive WS**

099-005262-EW501

Observe additional system documents!

22.11.2016

**Register now
and benefit!
Jetzt Registrieren
und Profitieren!**

www.ewm-group.com



General instructions

WARNING



Read the operating instructions!

The operating instructions provide an introduction to the safe use of the products.

- Read and observe the operating instructions for all system components, especially the safety instructions and warning notices!
- Observe the accident prevention regulations and any regional regulations!
- The operating instructions must be kept at the location where the machine is operated.
- Safety and warning labels on the machine indicate any possible risks. Keep these labels clean and legible at all times.
- The machine has been constructed to state-of-the-art standards in line with any applicable regulations and industrial standards. Only trained personnel may operate, service and repair the machine.
- Technical changes due to further development in machine technology may lead to a differing welding behaviour.



In the event of queries on installation, commissioning, operation or special conditions at the installation site, or on usage, please contact your sales partner or our customer service department on +49 2680 181-0.

A list of authorised sales partners can be found at www.ewm-group.com.

Liability relating to the operation of this equipment is restricted solely to the function of the equipment. No other form of liability, regardless of type, shall be accepted. This exclusion of liability shall be deemed accepted by the user on commissioning the equipment.

The manufacturer is unable to monitor whether or not these instructions or the conditions and methods are observed during installation, operation, usage and maintenance of the equipment.

An incorrectly performed installation can result in material damage and injure persons as a result. For this reason, we do not accept any responsibility or liability for losses, damages or costs arising from incorrect installation, improper operation or incorrect usage and maintenance or any actions connected to this in any way.

© EWM AG

Dr. Günter-Henle-Straße 8

56271 Mündersbach

Germany

The copyright to this document remains the property of the manufacturer.

Copying, including extracts, only permitted with written approval.

The content of this document has been prepared and reviewed with all reasonable care. The information provided is subject to change; errors excepted.

1 Contents

1	Contents	3
2	For your safety	5
2.1	Notes on the use of these operating instructions	5
2.1.1	Explanation of icons	6
2.2	Part of the complete documentation	7
3	Intended use	8
3.1	Use and operation solely with the following machines	8
3.2	Documents which also apply	9
3.2.1	Warranty	9
3.2.2	Declaration of Conformity	9
3.2.3	Service documents (spare parts and circuit diagrams)	9
3.2.4	Calibration/Validation	9
4	Machine description – quick overview	10
4.1	Front view	10
4.2	Inside view	11
5	Design and function	12
5.1	Transport and installation	12
5.1.1	Ambient conditions	12
5.1.1.1	In operation	12
5.1.1.2	Transport and storage.....	12
5.1.2	Machine cooling.....	13
5.1.3	Workpiece lead, general.....	13
5.1.4	Welding torch cooling system.....	14
5.1.4.1	Approved coolants overview	14
5.1.4.2	Maximal hose package length	14
5.1.5	Notes on the installation of welding current leads	15
5.1.5.1	Stray welding currents.....	16
5.2	Preparing the welding system.....	17
5.2.1	Switching between Push/Pull and intermediate drive	17
5.3	Welding torch connection	18
5.4	Hose package/intermediate drive connection.....	19
5.5	Wire feed.....	20
5.5.1	Open the protective flap of the wire feeder	20
5.5.2	Changing the wire feed rollers.....	20
5.5.3	Inching the wire electrode	21
5.6	Setting the operating point (welding output)	23
5.7	Replacing the steel liner in the hose package	24
6	Maintenance, care and disposal	26
6.1	General	26
6.2	Cleaning.....	26
6.3	Maintenance work, intervals	27
6.3.1	Daily maintenance tasks	27
6.3.1.1	Visual inspection	27
6.3.1.2	Functional test.....	27
6.3.2	Monthly maintenance tasks.....	27
6.3.2.1	Visual inspection	27
6.3.2.2	Functional test.....	27
6.3.3	Annual test (inspection and testing during operation)	28
6.4	Disposing of equipment	28
6.4.1	Manufacturer's declaration to the end user	28
6.5	Meeting the requirements of RoHS	28
7	Rectifying faults	29
7.1	Checklist for rectifying faults	29
7.2	Vent coolant circuit.....	30
8	Technical data	31

8.1	miniDrive	31
9	Accessories	32
9.1	Remote control / connection cable.....	32
9.2	General accessories	32
10	Replaceable parts.....	33
10.1	Conversion kit	33
10.2	Wire feed rollers	33
10.2.1	Wire feed rollers for steel wire	33
10.2.2	Wire feed rollers for aluminium wire	33
11	Appendix A.....	34
11.1	Circuit diagram – cable adapter	34
12	Appendix B.....	35
12.1	Overview of EWM branches.....	35

2 For your safety

2.1 Notes on the use of these operating instructions

DANGER

Working or operating procedures which must be closely observed to prevent imminent serious and even fatal injuries.

- Safety notes include the "DANGER" keyword in the heading with a general warning symbol.
- The hazard is also highlighted using a symbol on the edge of the page.

WARNING

Working or operating procedures which must be closely observed to prevent serious and even fatal injuries.

- Safety notes include the "WARNING" keyword in the heading with a general warning symbol.
- The hazard is also highlighted using a symbol in the page margin.

CAUTION

Working or operating procedures which must be closely observed to prevent possible minor personal injury.

- The safety information includes the "CAUTION" keyword in its heading with a general warning symbol.
- The risk is explained using a symbol on the edge of the page.



Special technical points which users must observe.

Instructions and lists detailing step-by-step actions for given situations can be recognised via bullet points, e.g.:

- Insert the welding current lead socket into the relevant socket and lock.

2.1.1 Explanation of icons

Symbol	Description	Symbol	Description
	Indicates technical aspects which the user must observe.		Activate and release/tap/tip
	Switch off machine		Release
	Switch on machine		Press and keep pressed
			Switch
	Wrong		Turn
	Correct		Numerical value – adjustable
	Menu entry		Signal light lights up in green
	Navigating the menu		Signal light flashes green
	Exit menu		Signal light lights up in red
	Time representation (e.g.: wait 4 s/activate)		Signal light flashes red
	Interruption in the menu display (other setting options possible)		
	Tool not required/do not use		
	Tool required/use		

2.2 Part of the complete documentation

These operating instructions are part of the complete documentation and valid only in combination with all other parts of these instructions! Read and observe the operating instructions for all system components, especially the safety instructions!

The illustration shows a general example of a welding system.

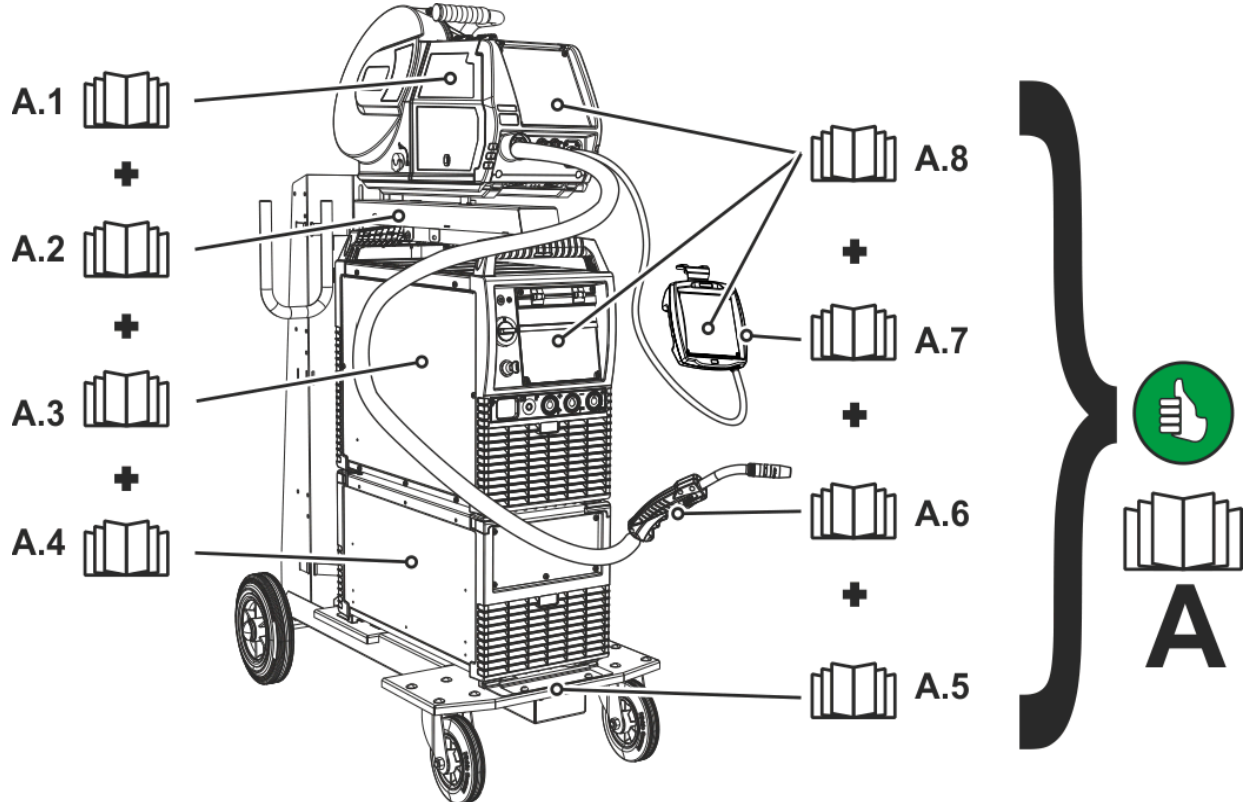

Figure 2-1

Item	Documentation
A.1	Wire feeder
A.2	Conversion instructions
A.3	Power source
A.4	Cooling unit, voltage converter, tool box etc.
A.5	Trolley
A.6	Welding torch
A.7	Remote control
A.8	Control
A	Complete documentation

3 Intended use

WARNING



Hazards due to improper usage!

The machine has been constructed to the state of the art and any regulations and standards applicable for use in industry and trade. It may only be used for the welding procedures indicated at the rating plate. Hazards may arise for persons, animals and material objects if the equipment is not used correctly. No liability is accepted for any damages arising from improper usage!

- The equipment must only be used in line with its designated purpose and by trained or expert personnel!
- Do not improperly modify or convert the equipment!

Wire feeder (intermediate drive) for welding wire electrodes used for gas-shielded metal-arc welding and hose packages of up to 25 m.

3.1 Use and operation solely with the following machines



A compact or decompact system component with wire feeder is required to operate the intermediate drive.



In addition, the system component has to be equipped with a current M 3.7X-X variant machine control (three digital displays).

The following machine series can be combined with the intermediate drive:

- Taurus Synergic S
- Phoenix
- alpha Q

All compact 355 TKM and 355 TKW machines in the relevant series are excluded.

3.2 Documents which also apply

3.2.1 Warranty



For more information refer to the "Warranty registration" brochure supplied and our information regarding warranty, maintenance and testing at www.ewm-group.com!

3.2.2 Declaration of Conformity



The labelled machine complies with the following EC directives in terms of its design and construction:

- Low Voltage Directive (LVD)
- Electromagnetic Compatibility Directive (EMC)
- Restriction of Hazardous Substance (RoHS)

In case of unauthorised changes, improper repairs, non-compliance with specified deadlines for "Arc Welding Equipment – Inspection and Testing during Operation", and/or prohibited modifications which have not been explicitly authorised by EWM, this declaration shall be voided. An original document of the specific declaration of conformity is included with every product.

3.2.3 Service documents (spare parts and circuit diagrams)

WARNING



Do not carry out any unauthorised repairs or modifications!

To avoid injury and equipment damage, the unit must only be repaired or modified by specialist, skilled persons!

The warranty becomes null and void in the event of unauthorised interference.

- Appoint only skilled persons for repair work (trained service personnel)!

Original copies of the circuit diagrams are enclosed with the unit.

Spare parts can be obtained from the relevant authorised dealer.

3.2.4 Calibration/Validation

We hereby confirm that this machine has been tested using calibrated measuring equipment, as stipulated in IEC/EN 60974, ISO/EN 17662, EN 50504, and complies with the admissible tolerances. Recommended calibration interval: 12 months

4 Machine description – quick overview

4.1 Front view

Connections and operating elements for torch cooling only with correspondent machine versions.

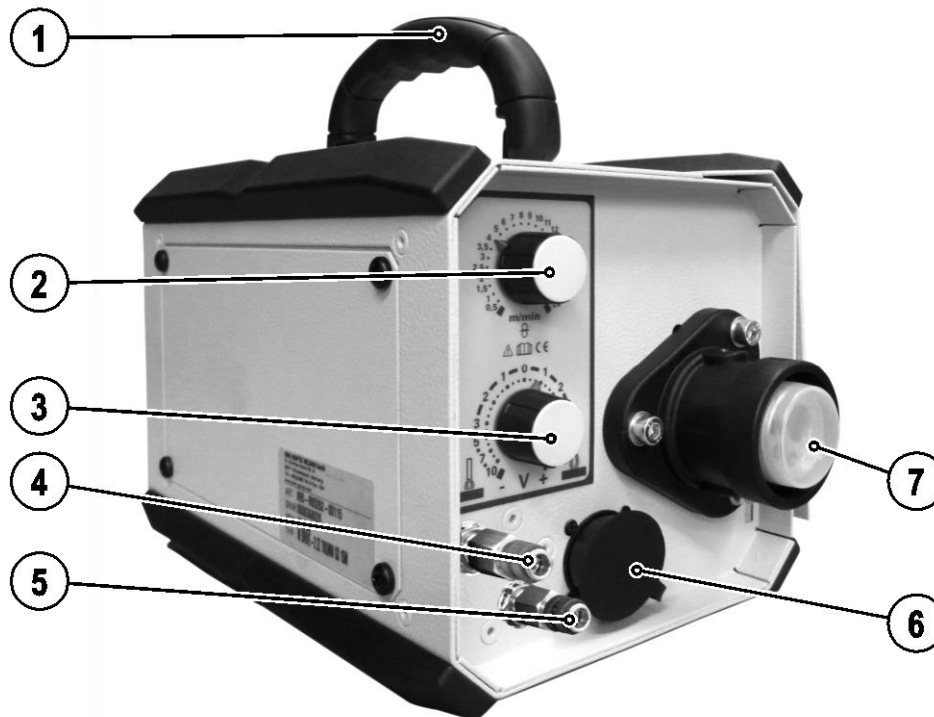

Figure 4-1

Item	Symbol	Description
1		Carrying handle
2		Wire speed rotary dial Infinitely adjustable setting of the wire speed from min. to max. (welding output, one-dial operation)
3		Rotary dial, Arc length correction Arc length correction from -10 V to + 10 V
4		Quick connect coupling (red) coolant return
5		Quick connect coupling (blue) coolant supply
6		19-pole connection socket (analogue) For connecting analogue accessory components (remote control, welding torch control lead, etc.)
7		Welding torch connection (Euro torch connector) Welding current, shielding gas and torch trigger integrated

4.2 Inside view

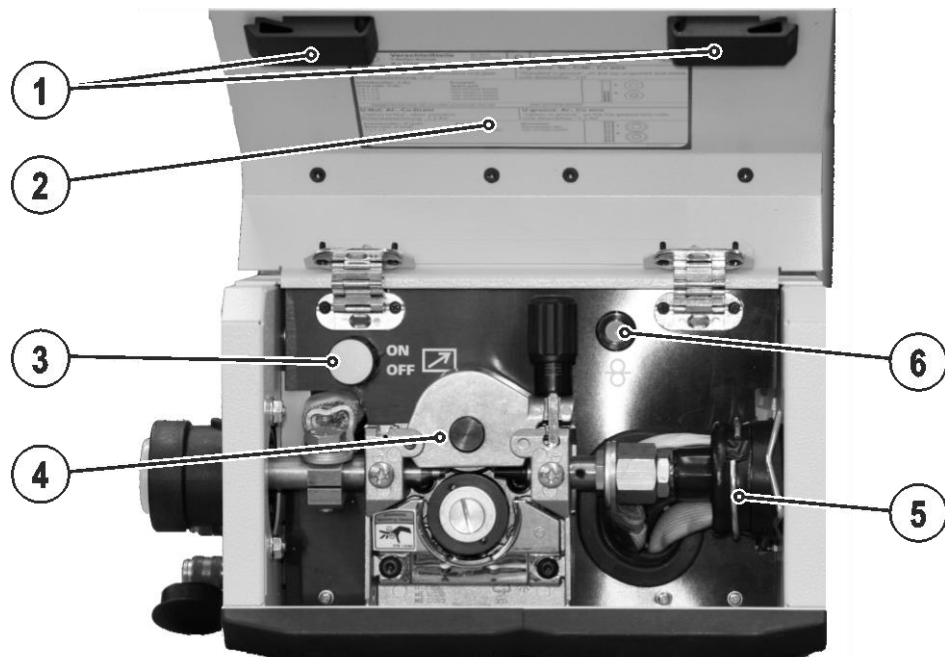

Figure 4-2

Item	Symbol	Description
1		Slide latch, lock for the protective cap
2		Protective cap Cover for the wire feed mechanism and other operating elements. Depending on the machine series, additional stickers with information on the replacement parts and JOB lists will be located on the inside.
3		Changeover switch, remote control on/off ON Set the welding performance via the remote control OFF Set the welding performance via the machine control
4		Wire feed unit
5		Intermediate hose package
6		Push-button, wire inching Potential- and gas-free inching of the wire electrode through the hose package to the welding torch > see 5.5.3 chapter.



The inching speed is infinitely adjustable by simultaneously pressing the wire inching push-button and turning the wire speed rotary knob.

5 Design and function

WARNING



Risk of injury from electric shock!

Contact with live parts, e.g. welding current sockets, is potentially fatal!

- Follow safety instructions on the opening pages of the operating instructions.
- Commissioning may only be carried out by persons who have the relevant expertise of working with arc welding machines!
- Connection and welding leads (e.g. electrode holder, welding torch, workpiece lead, interfaces) may only be connected when the machine is switched off!

5.1 Transport and installation

WARNING



Risk of accident due to improper transport of machines that must not be lifted!

Do not lift or suspend the machine! The machine can drop and cause injuries! The handles, straps or brackets are suitable for transport by hand only!

- The machine must not be suspended or lifted using a crane.



Read and observe the documentation to all system and accessory components!

5.1.1 Ambient conditions



The machine must not be operated in the open air and must only be set up and operated on a suitable, stable and level base!

- ***The operator must ensure that the ground is non-slip and level, and provide sufficient lighting for the place of work.***
- ***Safe operation of the machine must be guaranteed at all times.***



Unusually high quantities of dust, acid, corrosive gases or substances may damage the equipment.

- ***Avoid high volumes of smoke, vapour, oil vapour and grinding dust!***
- ***Avoid ambient air containing salt (sea air)!***

5.1.1.1 In operation

Temperature range of the ambient air:

- -25 °C to +40 °C

Relative air humidity:

- Up to 50% at 40 °C
- Up to 90% at 20 °C

5.1.1.2 Transport and storage

Storage in an enclosed space, temperature range of the ambient air:

- -30 °C to +70 °C

Relative air humidity

- Up to 90% at 20 °C

5.1.2 Machine cooling



Insufficient ventilation results in a reduction in performance and equipment damage.

- **Observe the ambient conditions!**
- **Keep the cooling air inlet and outlet clear!**
- **Observe the minimum distance of 0.5 m from obstacles!**

5.1.3 Workpiece lead, general

CAUTION



Risk of burning due to incorrect welding current connection!

If the welding current plugs (machine connections) are not locked or if the workpiece connection is contaminated (paint, corrosion), these connections and leads can heat up and cause burns when touched!

- Check welding current connections on a daily basis and lock by turning to the right when necessary.
- Clean workpiece connection thoroughly and secure properly. Do not use structural parts of the workpiece as welding current return lead!

5.1.4 Welding torch cooling system



Insufficient frost protection in the welding torch coolant!

Depending on the ambient conditions, different liquids are used for cooling the welding torch > see 5.1.4.1 chapter.

Coolants with frost protection (KF 37E or KF 23E) must be checked regularly to ensure that the frost protection is adequate to prevent damage to the machine or the accessory components.

- The coolant must be checked for adequate frost protection with the TYP 1 frost protection tester .
- Replace coolant as necessary if frost protection is inadequate!



Coolant mixtures!

Mixtures with other liquids or the use of unsuitable coolants result in material damage and renders the manufacturer's warranty void!

- Only use the coolant described in this manual (overview of coolants).
- Do not mix different coolants.
- When changing the coolant, the entire volume of liquid must be changed.



Dispose of the coolant in accordance with local regulations and the material safety data sheets (German waste code number: 70104).

May not be disposed of in household waste.

Prevent entry into sewers.

Absorb with liquid-binding material (sand, gravel, acid-binding agents, universal binding agents, sawdust).

5.1.4.1 Approved coolants overview

Coolant	Temperature range
KF 23E (Standard)	-10 °C to +40 °C
KF 37E	-20 °C to +10 °C

5.1.4.2 Maximal hose package length

	Pump 3.5 bar	Pump 4.5 bar
Machines with or without separate wire feeder	30 m	60 m
Compact machines with additional intermediate drive (example. miniDrive)	20 m	30 m
Machines with separate wire feeder and additional intermediate drive (example: miniDrive)	20 m	60 m

Data as a rule refer to the entire hose package length

including welding torch. The pump output is shown on the type plate (parameter: Pmax).

Pump 3.5 bar: Pmax = 0.35 MPa (3.5 bar)

Pump 4.5 bar: Pmax = 0.45 MPa (4.5 bar)

5.1.5 Notes on the installation of welding current leads

- Incorrectly installed welding current leads can cause faults in the arc (flickering).**
- Lay the workpiece lead and hose package of power sources without HF igniter (MIG/MAG) for as long and as close as possible in parallel.**
- Lay the workpiece lead and hose package of power sources with HF igniter (TIG) for as long as possible in parallel with a distance of 20 cm to avoid HF sparkover.**
- Always keep a distance of at least 20 cm to leads of other power sources to avoid interferences**
- Always keep leads as short as possible! For optimum welding results max. 30 m (welding lead + intermediate hose package + torch lead).**

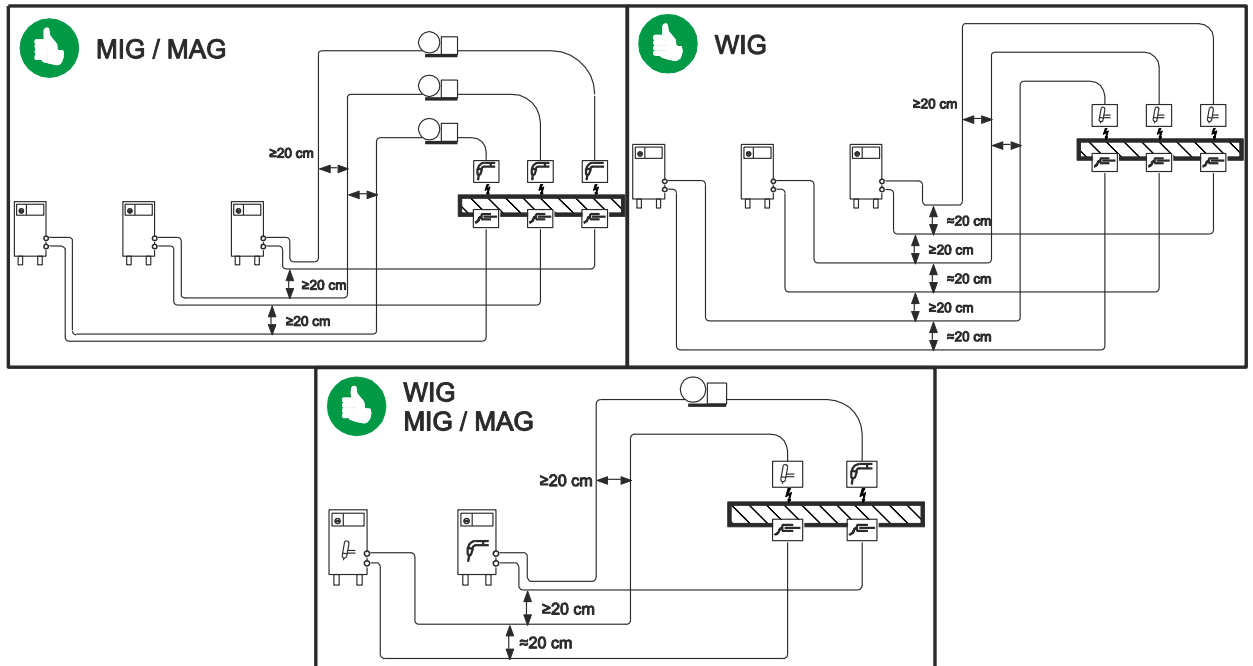

Figure 5-1

- Use an individual welding lead to the workpiece for each welding machine!**

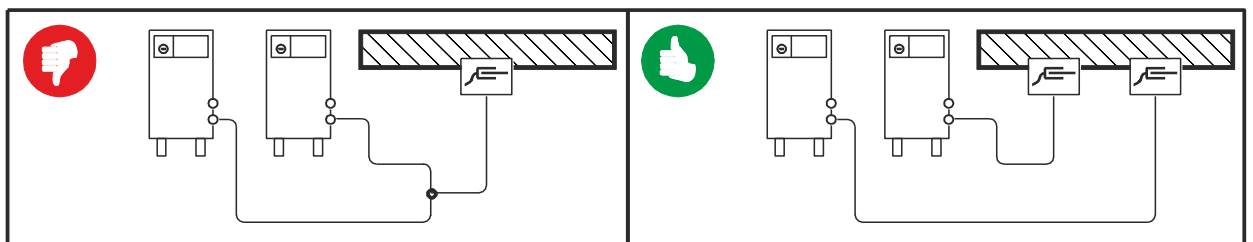

Figure 5-2

- Fully unroll welding current leads, torch hose packages and intermediate hose packages. Avoid loops!**
- Always keep leads as short as possible!**
- Lay any excess cable lengths in meanders.**

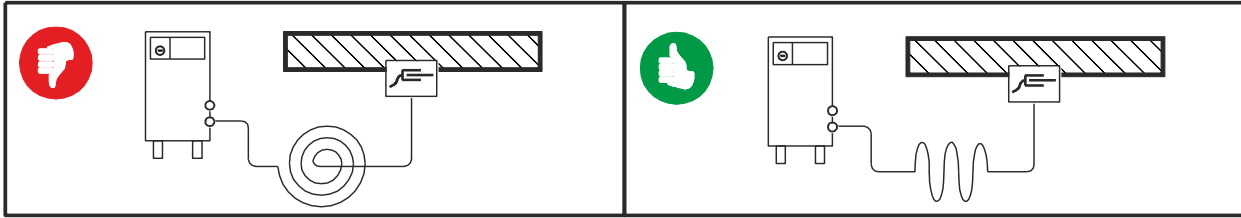

Figure 5-3

5.1.5.1 Stray welding currents

WARNING



Risk of injury due to stray welding currents!

Stray welding currents can destroy protective earth conductors, damage machines and electronic devices and cause overheating of components, leading to fire.

- Check that all welding current connections are firmly secured and electrical connections are in perfect condition.
- Set up, attach or suspend all conductive power source components such as casing, transport vehicles and crane frames so they are insulated.
- Do not place any other electronic devices such as drills or angle grinders on the power source, transport vehicle or crane frames unless they are insulated.
- Always put welding torches and electrode holders on an insulated surface when they are not in use.

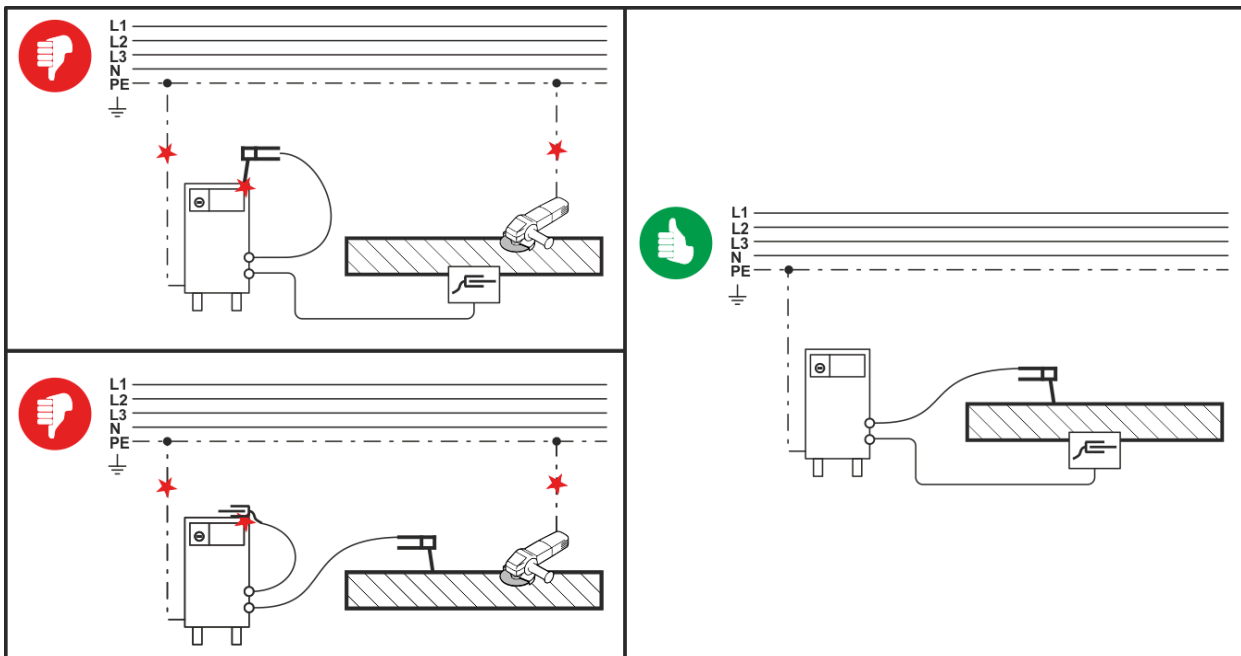

Figure 5-4

5.2 Preparing the welding system

5.2.1 Switching between Push/Pull and intermediate drive

⚠ WARNING



Do not carry out any unauthorised repairs or modifications!

To avoid injury and equipment damage, the unit must only be repaired or modified by specialist, skilled persons!

The warranty becomes null and void in the event of unauthorised interference.

- Appoint only skilled persons for repair work (trained service personnel)!

The wire feeder used in the welding system has to be modified for use with an intermediate drive. To do so, unscrew the casing cover and perform the following two actions on PCB M370/1:

Replug the connector (X23/X24)

Plug	Function
On X24	Use with push/pull welding torch (ex factory)
On X23	Use with intermediate drive

Install cable adapter

The cable adapter (included with the intermediate drive) has to be added to the wire feeder cable harness.

The cable adapter has to be plugged in at three locations (X2, X3 and X5) between the relevant PCB connections and cable plugs (see attached circuit diagram > see 11.1 chapter):

- PCB M370/1, connection X2 (18-pole)
- PCB M370/1, connection X3 (2-pole)
- PCB M370/1, connection X5 (12-pole)

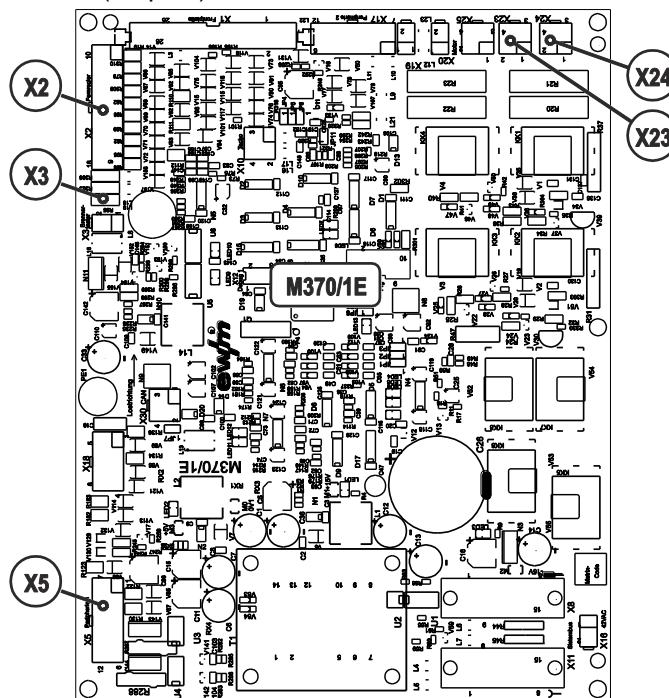

Figure 5-5



Test!

Before re-commissioning, it is essential that an "inspection and test during operation" is carried out conforming to IEC / DIN EN 60974-4 "Arc welding devices - inspection and testing during operation"!

- For detailed instructions, please see the standard operating instructions for the welding machine.

5.3 Welding torch connection



Equipment damage due to improperly connected coolant pipes!

If the coolant pipes are not properly connected or a gas-cooled welding torch is used, the coolant circuit is interrupted and equipment damage can occur.

- **Connect all coolant pipes correctly!**
- **Completely unroll the hose package and the torch hose package!**
- **Observe maximal hose package length > see 5.1.4.2 chapter.**
- **When using a gas-cooled welding torch, use a hose bridge to establish the coolant circuit > see 9 chapter.**



On delivery, the Euro torch connector is fitted with a capillary tube for welding torches with a steel liner. Conversion is necessary if a welding torch with a liner is used!

- **Operate welding torches with a liner > with a guide tube.**
- **Operate welding torches with a steel liner > with a capillary tube.**

Depending on the wire electrode diameter or type, either a steel liner or liner with the correct inner diameter must be inserted in the torch!

Recommendation:

- Use a steel liner when welding hard, unalloyed wire electrodes (steel).
- Use a chrome nickel liner when welding hard, high-alloy wire electrodes (CrNi).
- Use a plastic or teflon liner when welding or brazing soft wire electrodes, high-alloy wire electrodes or aluminium materials.

Preparation for connecting welding torches with a liner:

- Push forward the capillary tube on the wire feed side in the direction of the Euro torch connector and remove it there.
- Insert the liner guide tube from the Euro torch connector side.
- Carefully insert the welding torch connector with as yet too long a liner into the Euro torch connector and secure with a crown nut.
- Cut off the liner with a liner cutter > see 9 chapter just before the wire feed roller.
- Loosen the welding torch connector and remove.
- Carefully chamfer the cut off end of the liner with a liner sharpener > see 9 chapter and sharpen.

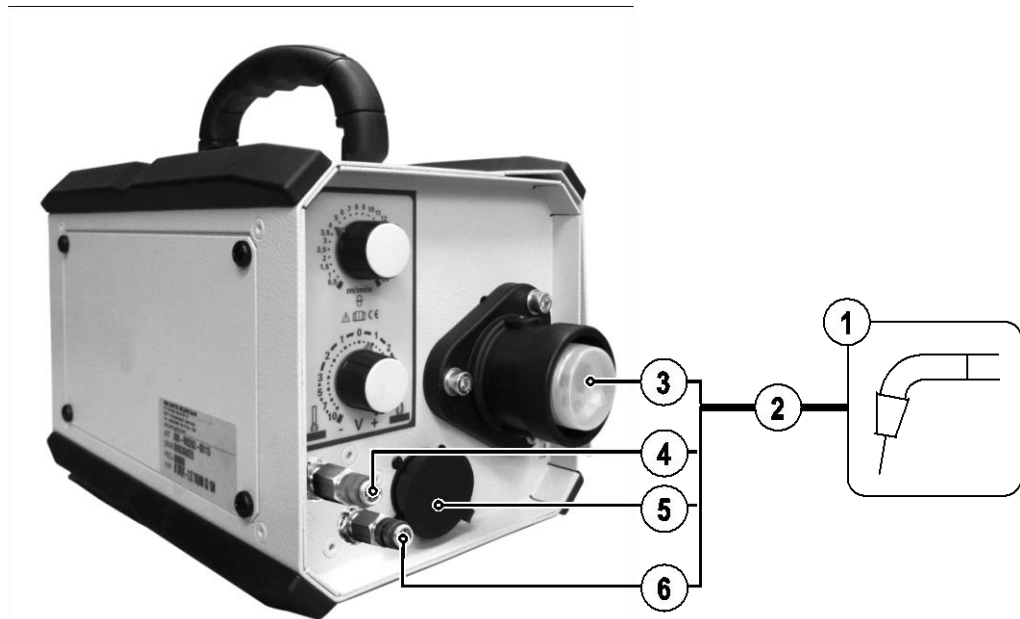

Figure 5-6

Item	Symbol	Description
1		Welding torch
2		Welding torch hose package
3		Welding torch connection (Euro torch connector) Welding current, shielding gas and torch trigger integrated
4		Quick connect coupling (red) coolant return
5		19-pole connection socket (analogue) For connecting analogue accessory components (remote control, welding torch control lead, etc.)
6		Quick connect coupling (blue) coolant supply

- Insert the central plug for the welding torch into the central connector and screw together with crown nut.

Where applicable:

- Insert the welding torch control cable into the 19-pole connection socket and lock (MIG/MAG torches with additional control cables only).
- Lock connecting nipples of the cooling water tubes into the corresponding quick connect couplings: Return line red to quick connect coupling, red (coolant return) and supply line blue to quick connect coupling, blue (coolant supply).

5.4 Hose package/intermediate drive connection

- Insert central connector of the intermediate hose package into the Euro torch connector of the relevant wire feeder (compact or decompact system component) and secure with crown nut.



Read and observe the documentation to all system and accessory components!

5.5 Wire feed

5.5.1 Open the protective flap of the wire feeder

 **To perform the following steps, the protective flap of the wire feeder needs to be opened. Make sure to close the protective flap again before starting to work.**

- Unlock and open protective flap.

5.5.2 Changing the wire feed rollers

 **Unsatisfactory welding results due to faulty wire feeding!**

Wire feed rollers must be suitable for the diameter of the wire and the material.

- **Check the roller label to verify that the rollers are suitable for the wire diameter. Turn or change if necessary!**
- **use V-groove rollers with for steel wires and other hard wires.**
- Slide new drive rollers into place so that the diameter of the wire used is visible on the drive roller.
- Screw the drive rollers in place with knurled screws.

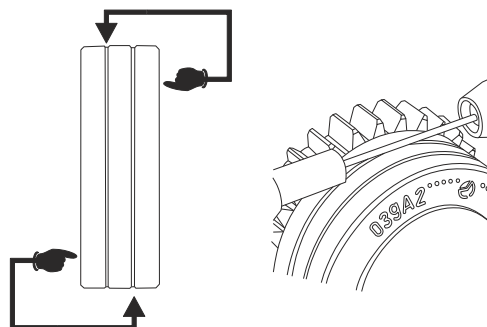

Figure 5-7

5.5.3 Inching the wire electrode

CAUTION



Risk of injury due to moving parts!

The wire feeders are equipped with moving parts, which can trap hands, hair, clothing or tools and thus injure persons!

- Do not reach into rotating or moving parts or drive components!
- Keep casing covers or protective caps closed during operation!



Risk of injury due to welding wire escaping in an unpredictable manner!

Welding wire can be conveyed at very high speeds and, if conveyed incorrectly, may escape in an uncontrolled manner and injure persons!

- Before mains connection, set up the complete wire guide system from the wire spool to the welding torch!
- Check wire guide at regular intervals!
- Keep all casing covers or protective caps closed during operation!



Risk of injury due to welding wire escaping from the welding torch!

The welding wire can escape from the welding torch at high speed and cause bodily injury including injuries to the face and eyes!

- Never direct the welding torch towards your own body or towards other persons!



Incorrect contact pressure will cause extensive wear of the wire feed rollers!

- ***With the adjusting nuts of the pressure units set the contact pressure so that the wire electrode is conveyed but will still slip through if the wire spool jams.***
- ***Set the contact pressure of the front rollers (in wire feed direction) to a higher value!***

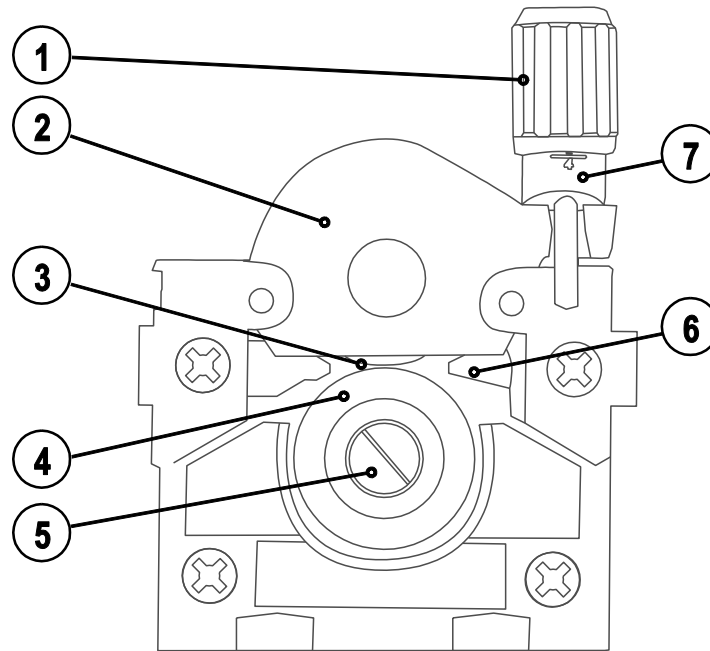

Figure 5-8

Item	Symbol	Description
1		Adjusting nut
2		Clamping unit
3		Pressure roller
4		Drive roller
5		Knurled screw
6		Wire feed nipple
7		Feed roll tensioner Fixing the clamping unit and setting the pressure.



- Extend and lay out the torch hose package.
- Flip feed roll tensioner down towards user (clamping unit will be released)
- Fold tensioning device up
- Carefully introduce the welding wire from the inlet guide through the drive roll grooves into the capillary tube or teflon liner with wire guide tube.
- Press the tensioning device back down and secure by folding the feed roll tensioner up (wire electrode should be in the groove on the drive roller)
- Set the contact pressure with the adjusting nuts of the feed roll tensioner
- Press the wire inching button until the wire electrode projects out of the welding torch.





The inching speed is infinitely adjustable by simultaneously pressing the wire inching push-button and turning the wire speed rotary knob. The left display shows the wire feed speed selected, the right display shows the current motor current of the wire feed mechanism.

5.6 Setting the operating point (welding output)

The operating point (welding power) is specified using the MIG/MAG one-knob operation principle, i.e. the user can specify either the welding current, the wire feed speed or the material thickness to define the operating point. The electronic system calculates the optimal required welding voltage value.

Operating element	Action	Result
		Operating point setting via wire speed.

The arc length can be corrected as follows.

Operating element	Action	Result
		Arc length correction

5.7 Replacing the steel liner in the hose package



Always make sure the the hose package is straight when replacing the wire guide.

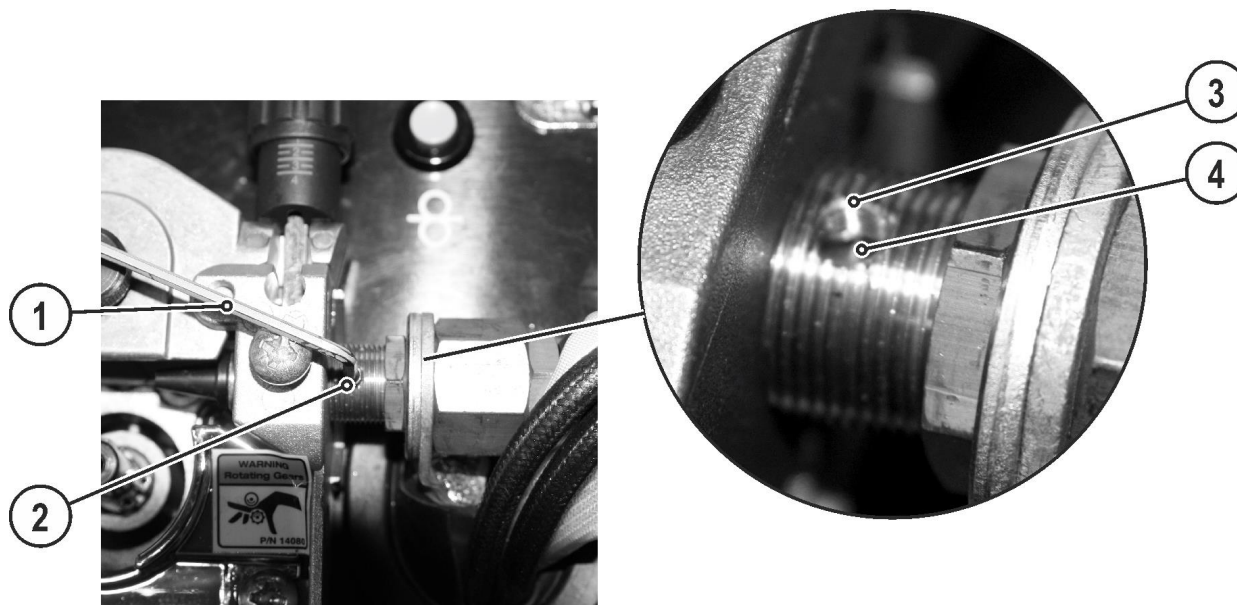

Figure 5-9

Item	Symbol	Description
1		Allen key (size 2.5)
2		Headless screw
3		Threaded hole
4		Steel liner

- Unscrew the headless screw using an Allen key (to release the steel liner from the wire feed mechanism)

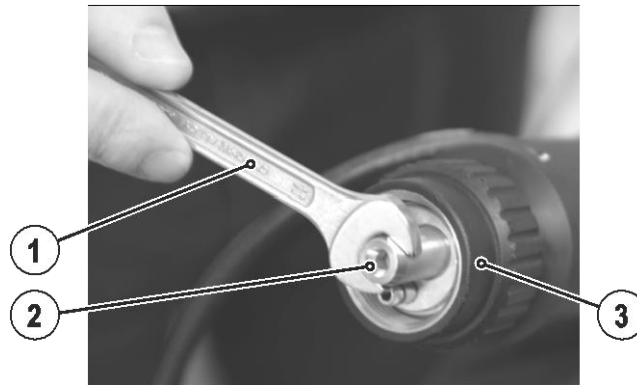



Figure 5-10

Item	Symbol	Description
1		Open-ended spanner, SW 11
2		Crown nut
3		Euro central connection Welding current, shielding gas and torch trigger included

- Loosen the crown nut of the liner fastening
- Pull out steel liner

Due to production tolerances the steel liner length has to be adapted to the hose package used.

- Place new and old steel liner in parallel
- Shorten new steel liner to the total length of the old one
- Insert new steel liner into the Euro torch connector as far as it goes (the steel liner has to be visible inside the headless screw threaded hole)
- Retighten the crown nut of the liner fastening
- Screw headless screw back in using the Allen key (max. torque 2 Nm)

6 Maintenance, care and disposal

6.1 General

DANGER



Incorrect maintenance and testing!

The machine may be cleaned, repaired and tested by skilled and qualified personnel only. A qualified person is one who, due to their training, knowledge and experience, can detect any hazards and possible consequential damage when checking the machine, and can take the necessary safety measures.

- Observe the maintenance instructions > see 6.3 chapter!
- The machine may only be put into operation again once the testing has been successful.



Risk of injury due to electrical voltage after switching off!

Working on an open machine can lead to fatal injuries!

Capacitors are loaded with electrical voltage during operation. Voltage remains present for up to four minutes after the mains plug is removed.

1. Switch off machine.
2. Remove the mains plug.
3. Wait for at last 4 minutes until the capacitors have discharged!

WARNING



Cleaning, testing and repair!

Cleaning, testing and repairing of the welding machine may only be carried out by competent, qualified personnel. A qualified person is one who, because of his or her training, knowledge and experience, is able to recognise the dangers that can occur while testing welding power sources as well as possible subsequent damage, and who is able to implement the required safety procedures.

- In the event of failure of any one of the following tests, the machine must not be operated again until it has been repaired and a new test has been carried out.

Repair and maintenance work may only be performed by qualified authorised personnel; otherwise the right to claim under warranty is void. In all service matters, always consult the dealer who supplied the machine. Return deliveries of defective equipment subject to warranty may only be made through your dealer. When replacing parts, use only original spare parts. When ordering spare parts, please quote the machine type, serial number and item number of the machine, as well as the type designation and item number of the spare part.

Under the specified ambient conditions and normal working conditions this machine is essentially maintenance-free and requires just a minimum of care.

Contamination of the machine may impair service life and duty cycle. The cleaning intervals depend on the ambient conditions and the resulting contamination of the machine. The minimum interval is every six months.

6.2 Cleaning

- Clean the outer surfaces with a moist cloth (no aggressive cleaning agents).
- Purge the machine venting channel and cooling fins (if present) with oil- and water-free compressed air. Compressed air may overspeed and destroy the machine fans. Never direct the compressed air directly at the machine fans. Mechanically block the fans, if required.
- Check the coolant for contaminants and replace, if necessary.

6.3 Maintenance work, intervals

Repair and maintenance work may only be performed by qualified authorised personnel; otherwise the right to claim under warranty is void. In all service matters, always consult the dealer who supplied the machine. Return deliveries of defective equipment subject to warranty may only be made through your dealer. When replacing parts, use only original spare parts. When ordering spare parts, please quote the machine type, serial number and item number of the machine, as well as the type designation and item number of the spare part.

6.3.1 Daily maintenance tasks

6.3.1.1 Visual inspection

- Mains supply lead and its strain relief
- Gas cylinder securing elements
- Check hose package and power connections for exterior damage and replace or have repaired by specialist staff as necessary!
- Gas tubes and their switching equipment (solenoid valve)
- Check that all connections and wearing parts are hand-tight and tighten if necessary.
- Check correct mounting of the wire spool.
- Wheels and their securing elements
- Transport elements (strap, lifting lugs, handle)
- Other, general condition

6.3.1.2 Functional test

- Operating, message, safety and adjustment devices (Functional test)
- Welding current cables (check that they are fitted correctly and secured)
- Gas tubes and their switching equipment (solenoid valve)
- Gas cylinder securing elements
- Check correct mounting of the wire spool.
- Check that all screw and plug connections and replaceable parts are secured correctly, tighten if necessary.
- Remove any spatter.
- Clean the wire feed rollers on a regular basis (depending on the degree of soiling).

6.3.2 Monthly maintenance tasks

6.3.2.1 Visual inspection

- Casing damage (front, rear and side walls)
- Wheels and their securing elements
- Transport elements (strap, lifting lugs, handle)
- Check coolant tubes and their connections for impurities

6.3.2.2 Functional test

- Selector switches, command devices, emergency stop devices, voltage reducing devices, message and control lamps
- Check that the wire guide elements (inlet nipple, wire guide tube) are fitted securely.
- Check coolant tubes and their connections for impurities
- Check and clean the welding torch. Deposits in the torch can cause short circuits and have a negative impact on the welding result, ultimately causing damage to the torch.

6.3.3 Annual test (inspection and testing during operation)

 **The welding machine may only be tested by competent, capable persons! A capable person is one who, because of his training, knowledge and experience, is able to recognise the dangers that can occur while testing welding power sources as well as possible subsequent damage and who is able to implement the required safety procedures.**

 **For more information refer to the "Warranty registration" brochure supplied and our information regarding warranty, maintenance and testing at www.ewm-group.com!**

A periodic test according to IEC 60974-4 "Periodic inspection and test" has to be carried out. In addition to the regulations on testing given here, the relevant local laws and regulations must also be observed.

6.4 Disposing of equipment

 **Proper disposal!**

The machine contains valuable raw materials, which should be recycled, and electronic components, which must be disposed of.

- **Do not dispose of in household waste!**
- **Observe the local regulations regarding disposal!**



6.4.1 Manufacturer's declaration to the end user

- According to European provisions (guideline 2012/19/EU of the European Parliament and the Council of July, 4th 2012), used electric and electronic equipment may no longer be placed in unsorted municipal waste. It must be collected separately. The symbol depicting a waste container on wheels indicates that the equipment must be collected separately. This machine is to be placed for disposal or recycling in the waste separation systems provided for this purpose.
- According to German law (law governing the distribution, taking back and environmentally correct disposal of electric and electronic equipment (ElektroG) from 16.03.2005), used machines are to be placed in a collection system separate from unsorted municipal waste. The public waste management utilities (communities) have created collection points at which used equipment from private households can be disposed of free of charge.
- Information about giving back used equipment or about collections can be obtained from the respective municipal administration office.
- EWM participates in an approved waste disposal and recycling system and is registered in the Used Electrical Equipment Register (EAR) under number WEEE DE 57686922.
- In addition to this, returns are also possible throughout Europe via EWM sales partners.

6.5 Meeting the requirements of RoHS

We, EWM AG in Mündersbach, Germany, hereby confirm that all products which we supply to you and that are subject to the RoHS directive comply with RoHS requirements (also see applicable EC directives on the Declaration of Conformity on your machine).

7 Rectifying faults

All products are subject to rigorous production checks and final checks. If, despite this, something fails to work at any time, please check the product using the following flowchart. If none of the fault rectification procedures described leads to the correct functioning of the product, please inform your authorised dealer.

7.1 Checklist for rectifying faults



The correct machine equipment for the material and process gas in use is a fundamental requirement for perfect operation!

Legend	Symbol	Description
	↘	Fault/Cause
	✘	Remedy

Coolant error/no coolant flowing

- ↘ Insufficient coolant flow
 - ✘ Check coolant level and refill if necessary
- ↘ Air in the coolant circuit
 - ✘ Vent coolant circuit > see 7.2 chapter

Wire feed problems

- ↘ Contact tip blocked
 - ✘ Clean, spray with anti-spatter spray and replace if necessary
- ↘ Setting the spool brake
 - ✘ Check settings and correct if necessary
- ↘ Setting pressure units > see 5.5.3 chapter
 - ✘ Check settings and correct if necessary
- ↘ Worn wire rolls
 - ✘ Check and replace if necessary
- ↘ Wire feed motor without supply voltage (automatic cutout triggered by overloading)
 - ✘ Reset triggered fuse (rear of the power source) by pressing the key button
- ↘ Kinked hose packages
 - ✘ Extend and lay out the torch hose package
- ↘ Wire guide core or spiral is dirty or worn
 - ✘ Clean core or spiral; replace kinked or worn cores

Functional errors

- ↘ All machine control signal lights are illuminated after switching on
- ↘ No machine control signal light is illuminated after switching on
- ↘ No welding power
 - ✘ Phase failure > check mains connection (fuses)
- ↘ Various parameters cannot be set
 - ✘ Entry level is blocked, disable access lock
- ↘ Connection problems
 - ✘ Make control lead connections and check that they are fitted correctly.
- ↘ Loose welding current connections
 - ✘ Tighten power connections on the torch and/or on the workpiece
 - ✘ Tighten contact tip correctly

7.2 Vent coolant circuit

- Coolant tank and quick connect coupling of coolant supply and return are only fitted in machines with water cooling.**
- To vent the cooling system always use the blue coolant connection, which is located as deep as possible inside the system (close to the coolant tank)!**

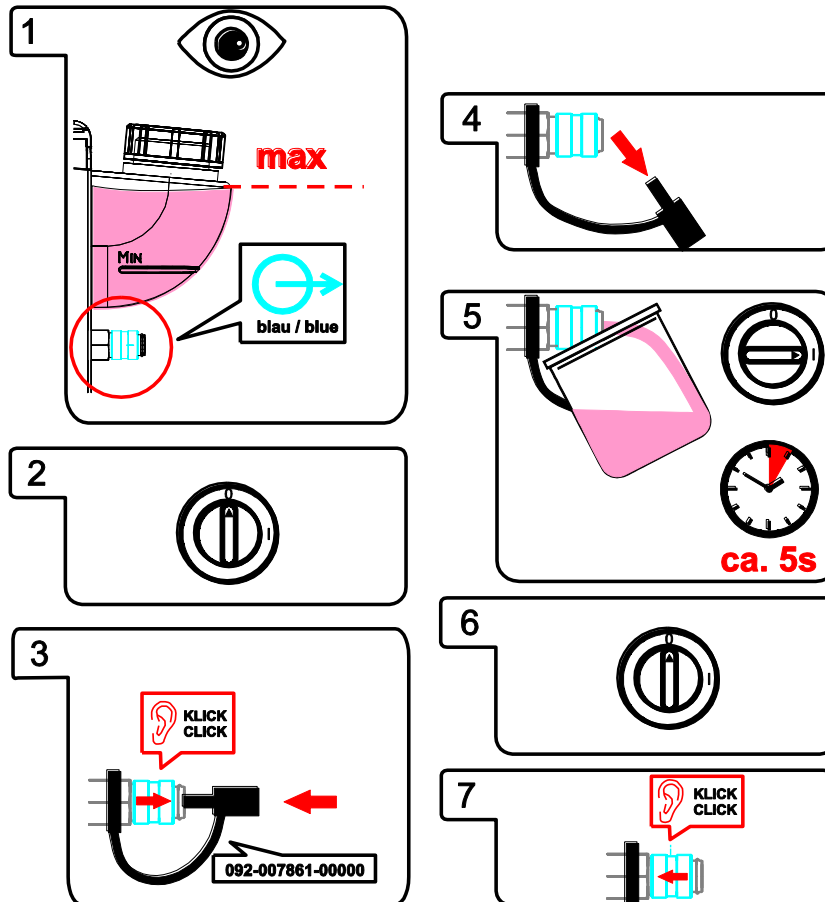

Figure 7-1

8 Technical data



Performance specifications and guarantee only in connection with original spare and replacement parts!

8.1 miniDrive

Supply voltage	60 VDC
Max. welding current (100% DC)	300 A
Max. welding current (60% DC)	400 A
Wire feed speed	1 m/min–20 m/min
Standard roll installation	1.0 + 1.2 mm (for steel wire)
Drive rolls	37 mm
Euro torch connector	Euro torch connector
Protection classification	IP 23
Ambient temperature	-25 °C to +40 °C
EMC class	A
Safety identification	CE / EAC
Harmonised standards used	IEC 60974-1, -5, -10
Dimensions L x W x H	300 mm x 180 mm x 200 mm
Weight excl. hose package	7.5 kg

9 Accessories



Performance-dependent accessories like torches, workpiece leads, electrode holders or intermediate hose packages are available from your authorised dealer.

9.1 Remote control / connection cable

Type	Designation	Item no.
R10 19POL	Remote control	090-008087-00000
RG10 19POL 5M	Remote control to set the wire speed and welding voltage correction	090-008108-00000
R20 19POL	Program changeover remote control	090-008263-00000
RA5 19POL 5M	Remote control e.g. connection cable	092-001470-00005
RA10 19POL 10M	Remote control e.g. connection cable	092-001470-00010

9.2 General accessories

Type	Designation	Item no.
SPL	Sharpener for plastic liners	094-010427-00000
HC PL	Hose cutter	094-016585-00000

10 Replaceable parts



The manufacturer's warranty becomes void if non-genuine parts are used!

- Only use system components and options (power sources, welding torches, electrode holders, remote controls, spare parts and replacement parts, etc.) from our range of products!
- Only insert and lock accessory components into the relevant connection socket when the machine is switched off.

10.1 Conversion kit

Type	Designation	Item no.
URUE AL 2R 10m miniDrive	Conversion kit for aluminium consisting of two drive pinions, liner and mounting material	092-007906-00010
URUE AL 2R 15m miniDrive	Conversion kit for aluminium consisting of two drive pinions, liner and mounting material	092-007906-00015

10.2 Wire feed rollers

10.2.1 Wire feed rollers for steel wire

Type	Designation	Item no.
FE 1DR2R 0.8+1.0	Drive rollers, 37mm, steel	094-003218-00000
FE 1DR2R 0.9+1.2	Drive rollers, 37mm, steel	094-003221-00000
FE 1DR2R 1.0+1.2	Drive rollers, 37mm, steel	094-003219-00000
FE 1DR2R 1,2+1,6	Drive rollers, 37 mm, steel	094-003220-00000
FE GR2R	Pressure roller, smooth, 37 mm	092-007908-00000

10.2.2 Wire feed rollers for aluminium wire

Type	Designation	Item no.
AL 2ZR2R 1,2+1,6	Twin wire feed rollers, 37 mm, for aluminium	092-000829-00000



<p>Verschleißteile 2 Rollen-Antrieb Ø = 37mm St= Stahl Al= Aluminium CrNi= Edelstahl Cu= Kupfer</p> 	<p>V-Nut: St-, CrNi-, Cu-Draht / Füll-/Röhrchendraht „Standard V-Nut“ oben unverzahnt und glatt</p> <p>Antriebsrollen- Ø (b): Drive rolls- Ø (b):</p> <table> <tr> <td>0,8 + 1,0</td> <td>Ersatzteil: Spare part:</td> </tr> <tr> <td>0,9 + 1,2</td> <td>094-003218-00000</td> </tr> <tr> <td>1,0 + 1,2</td> <td>094-003221-00000</td> </tr> <tr> <td>1,2 + 1,6</td> <td>094-003219-00000</td> </tr> <tr> <td></td> <td>094-003220-00000</td> </tr> </table>  <p>Gegendruckrolle (a) counter pressure roll (a) 092-007908-00000</p>	0,8 + 1,0	Ersatzteil: Spare part:	0,9 + 1,2	094-003218-00000	1,0 + 1,2	094-003221-00000	1,2 + 1,6	094-003219-00000		094-003220-00000	<p>U-Nut: Al-, Cu-Draht „Option U-Nut“ oben verzahnt</p> <p>Antriebsrollen- Ø (a+b): Drive rolls- Ø (a+b):</p> <table> <tr> <td>1,2 + 1,6</td> <td>Ersatzteil: Spare part:</td> </tr> <tr> <td></td> <td>092-000829-00000</td> </tr> </table>  <p>Umrüstset: Conversion set: 092-007906-00010 092-007906-00015</p>	1,2 + 1,6	Ersatzteil: Spare part:		092-000829-00000
0,8 + 1,0	Ersatzteil: Spare part:															
0,9 + 1,2	094-003218-00000															
1,0 + 1,2	094-003221-00000															
1,2 + 1,6	094-003219-00000															
	094-003220-00000															
1,2 + 1,6	Ersatzteil: Spare part:															
	092-000829-00000															
<p>Wear parts 2-Roller drive system Ø = 37mm St= Steel Al= Aluminium CrNi= Stainless steel Cu= Copper</p> 	<p>V-groove: St-, CrNi-, Cu wire / cored wire "Standard V-groove" on the top ungeared and plane</p>	<p>U-groove: Al-, Cu wire "Option U-groove" on the top geared-twin rolls</p>														

Figure 10-1

11 Appendix A

11.1 Circuit diagram – cable adapter

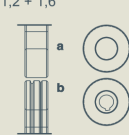
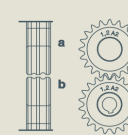
⚠ WARNING

Do not carry out any unauthorised repairs or modifications!

To avoid injury and equipment damage, the unit must only be repaired or modified by specialist, skilled persons!

The warranty becomes null and void in the event of unauthorised interference.

- Appoint only skilled persons for repair work (trained service personnel)!

Configuration > see 5.2.1 chapter

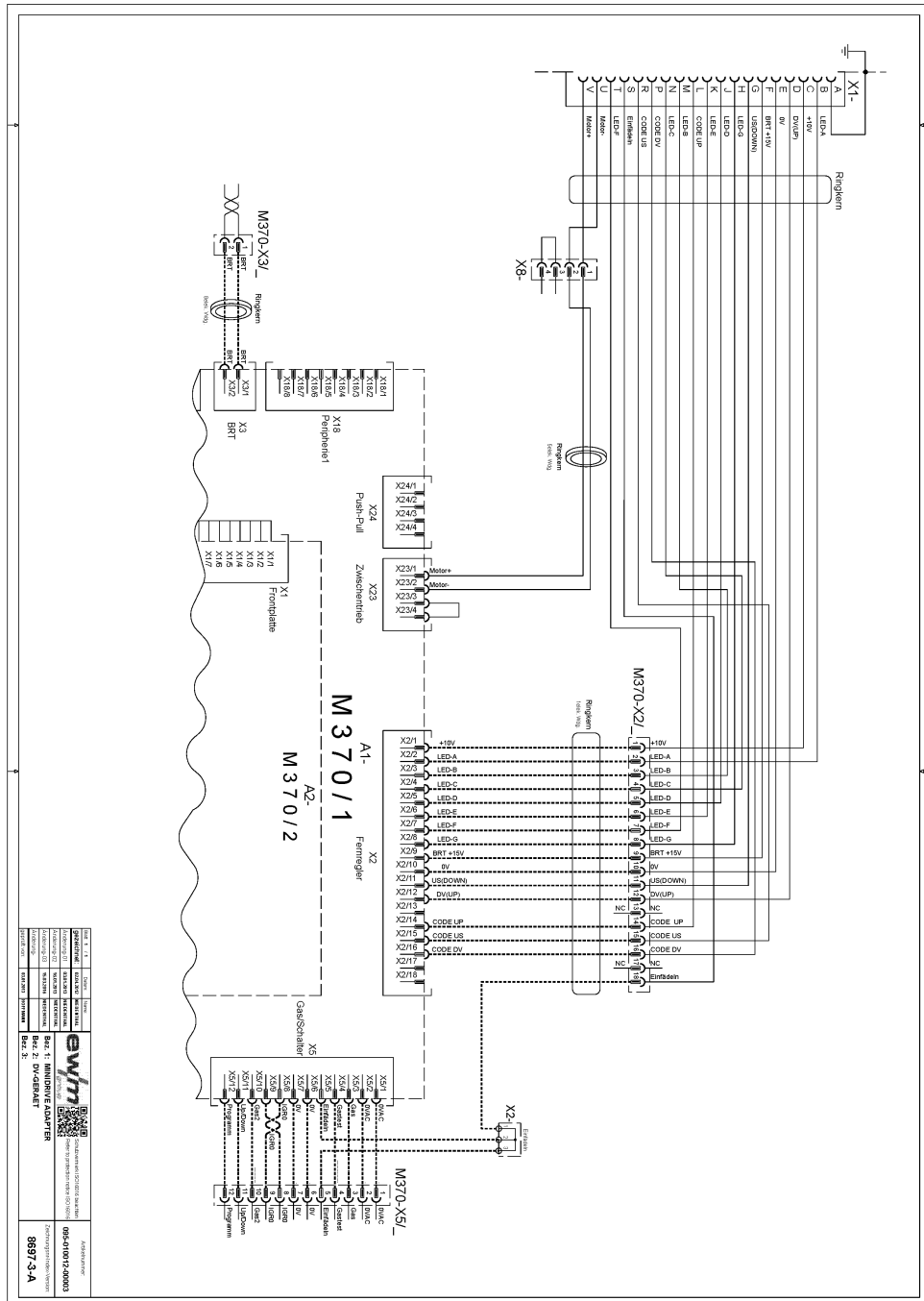

Figure 11-1

12 Appendix B

12.1 Overview of EWM branches

Headquarters

EWM AG
 Dr. Günter-Henle-Straße 8
 56271 Mündersbach · Germany
 Tel: +49 2680 181-0 · Fax: -244
www.ewm-group.com · info@ewm-group.com

Technology centre

EWM AG
 Forststraße 7-13
 56271 Mündersbach · Germany
 Tel: +49 2680 181-0 · Fax: -144
www.ewm-group.com · info@ewm-group.com



Production, Sales and Service

EWM AG
 Dr. Günter-Henle-Straße 8
 56271 Mündersbach · Germany
 Tel: +49 2680 181-0 · Fax: -244
www.ewm-group.com · info@ewm-group.com

EWM HIGH TECHNOLOGY (Kunshan) Ltd.
 10 Yuanshan Road, Kunshan · New & Hi-tech Industry Development Zone
 Kunshan City · Jiangsu · Post code 215300 · People's Republic of China
 Tel: +86 512 57867-188 · Fax: -182
www.ewm.cn · info@ewm.cn · info@ewm-group.cn

EWM HIGHTEC WELDING s.r.o.
 9. května 718 / 31
 407 53 Jiríkov · Czech Republic
 Tel.: +420 412 358-551 · Fax: -504
www.ewm-jirikov.cz · info@ewm-jirikov.cz

Sales and Service Germany

EWM AG
 Sales and Technology Centre
 Grünauer Fenn 4
 14712 Rathenow · Tel: +49 3385 49402-0 · Fax: -20
www.ewm-rathenow.de · info@ewm-rathenow.de

EWM AG
 Rudolf-Winkel-Straße 7-9
 37079 Göttingen · Tel: +49 551-3070713-0 · Fax: -20
www.ewm-goettingen.de · info@ewm-goettingen.de

EWM AG
 Dieselstraße 9b
 50259 Pulheim · Tel: +49 2238-46466-0 · Fax: -14
www.ewm-pulheim.de · info@ewm-pulheim.de

EWM AG
 August-Horch-Straße 13a
 56070 Koblenz · Tel: +49 261 963754-0 · Fax: -10
www.ewm-koblenz.de · info@ewm-koblenz.de

EWM AG
 Eiserfelder Straße 300
 57080 Siegen · Tel: +49 271 3878103-0 · Fax: -9
www.ewm-siegen.de · info@ewm-siegen.de

EWM HIGHTEC WELDING GmbH
 Technology and mechanisation Centre
 Daimlerstr. 4-6
 69469 Weinheim · Tel: +49 6201 84557-0 · Fax: -20
www.ewm-mechanisierung.de · info@ewm-weinheim.de

EWM Schweißtechnik Handels GmbH
 Karlsdorfer Straße 43
 88069 Tettngang · Tel: +49 7542 97998-0 · Fax: -29
www.ewm-tettngang.de · info@ewm-tettngang.de

EWM Schweißtechnik Handels GmbH
 Heinkelstraße 8
 89231 Neu-Ulm · Tel: +49 731 7047939-0 · Fax: -15
www.ewm-neu-ulm.de · info@ewm-neu-ulm.de

Sales and Service International

EWM HIGH TECHNOLOGY (Kunshan) Ltd.
 10 Yuanshan Road, Kunshan · New & Hi-tech Industry Development Zone
 Kunshan City · Jiangsu · Post code 215300 · People's Republic of China
 Tel: +86 512 57867-188 · Fax: -182
www.ewm.cn · info@ewm.cn · info@ewm-group.cn

EWM HIGHTEC WELDING GmbH
 Wiesenstraße 27b
 4812 Pinsdorf · Austria · Tel: +43 7612 778 02-0 · Fax: -20
www.ewm-austria.at · info@ewm-austria.at

EWM KAYNAK SISTEMLERİ TIC. LTD.STİ.
 İkitelli OSB Mah. · Marmara Sanayi Sitesi P Blok Apt. No: 44
 Küçükçekmece / Istanbul Turkey
 Tel.: +90 212 494 32 19
www.ewm.com.tr · turkey@ewm-group.com

EWM HIGHTEC WELDING UK Ltd.
 Unit 2B Coopies Way · Coopies Lane Industrial Estate
 Morpeth · Northumberland · NE61 6JN · Great Britain
 Tel: +44 1670 505875 · Fax: -514305
www.ewm-morpeth.co.uk · info@ewm-morpeth.co.uk

EWM HIGHTEC WELDING Sales s.r.o. / Prodejní a poradenské centrum
 Tyršova 2106
 256 01 Benešov u Prahy · Czech Republic
 Tel: +420 317 729-517 · Fax: -712
www.ewm-benesov.cz · info@ewm-benesov.cz

 Plants

 Branches

● More than 400 EWM sales partners worldwide