



Welding machine

Mira 151 KGE
Mira 221 MV KGE
Mira 251 KGE
Mira 301 KGE - M1.02

099-005084-EW501

22.09.2011

Register now!
For your benefit
Jetzt Registrieren
und Profitieren!

www.ewm-group.com



3 Years **5** Years
transformer
and rectifier

ewm-warranty*
24 hours / 7 days

* Details for ewm-warranty
www.ewm-group.com

General instructions

CAUTION



Read the operating instructions!

The operating instructions provide an introduction to the safe use of the products.

- Read the operating instructions for all system components!
- Observe accident prevention regulations!
- Observe all local regulations!
- Confirm with a signature where appropriate.

NOTE



In the event of queries on installation, commissioning, operation or special conditions at the installation site, or on usage, please contact your sales partner or our customer service department on +49 2680 181-0.

A list of authorised sales partners can be found at www.ewm-group.com.

Liability relating to the operation of this equipment is restricted solely to the function of the equipment. No other form of liability, regardless of type, shall be accepted. This exclusion of liability shall be deemed accepted by the user on commissioning the equipment.

The manufacturer is unable to monitor whether or not these instructions or the conditions and methods are observed during installation, operation, usage and maintenance of the equipment.

An incorrectly performed installation can result in material damage and injure persons as a result. For this reason, we do not accept any responsibility or liability for losses, damages or costs arising from incorrect installation, improper operation or incorrect usage and maintenance or any actions connected to this in any way.

© EWM HIGHTEC WELDING GmbH · Dr. Günter-Henle-Str. 8 · D-56271 Mündersbach, Germany

The copyright to this document remains the property of the manufacturer.

Reprinting, including extracts, only permitted with written approval.

Subject to technical amendments.

1 Contents

1	Contents	3
2	Safety instructions	5
2.1	Notes on the use of these operating instructions	5
2.2	Explanation of icons	6
2.3	General	7
2.4	Transport and installation	11
2.5	Ambient conditions	12
2.5.1	In operation	12
2.5.2	Transport and storage	12
3	Intended use	13
3.1	Applications	13
3.1.1	MIG/MAG standard welding	13
3.2	Overview of device types	13
3.2.1	Multi-voltage machine (MV)	13
3.3	Documents which also apply	14
3.3.1	Warranty	14
3.3.2	Declaration of Conformity	14
3.3.3	Welding in environments with increased electrical hazards	14
3.3.4	Service documents (spare parts and circuit diagrams)	14
4	Machine description – quick overview	15
4.1	Front view	15
4.2	Rear view	16
4.2.1	Inside view	17
4.3	Machine control – Operating elements	18
4.3.1	Mira 151	18
4.3.2	Mira 221 MV	19
4.3.3	Mira 251	20
4.3.4	Mira 301	21
5	Design and function	22
5.1	General	22
5.2	Installation	23
5.3	Machine cooling	23
5.4	Workpiece lead, general	23
5.5	Mains connection	24
5.6	Mira 151	24
5.6.1	Mira 221 MV	25
5.6.1.1	Connection with 230 V mains voltage	25
5.6.1.2	Connection with 400 V mains voltage	26
5.6.2	Mira 251, 301	27
5.7	Welding torch and workpiece line connection	28
5.8	Shielding gas supply	30
5.8.1	Connecting the shielding gas supply	31
5.8.2	Setting the shielding gas quantity	32
5.9	Inserting the wire electrode	33
5.9.1	Inserting the wire spool	33
5.9.2	Changing the wire feed rollers	34
5.9.3	Inching the wire electrode	35
5.9.4	Spool brake setting	37
5.9.5	MIG/MAG operating point	38
5.10	MIG/MAG functional sequences / operating modes	38
5.10.1	Explanation of signs and functions	38
5.10.2	Non-latched operation	39
5.10.3	Latched operation	39
5.10.4	Spot welding	40
5.10.5	Interval	41

6	Maintenance, care and disposal	42
6.1	General.....	42
6.2	Maintenance work, intervals.....	42
6.2.1	Daily maintenance tasks.....	42
6.2.2	Monthly maintenance tasks	42
6.2.3	Annual test (inspection and testing during operation)	42
6.3	Maintenance work	43
6.4	Disposing of equipment.....	43
6.4.1	Manufacturer's declaration to the end user	43
6.5	Meeting the requirements of RoHS.....	43
7	Rectifying faults	44
7.1	Customer checklist.....	44
8	Technical data	45
8.1	Mira 151, 221 MV, 251, 301	45
9	Accessories	46
9.1	General accessories	46
10	Replaceable parts	47
10.1	Wire feed rollers	47
10.1.1	2-roll drive	47
10.1.1.1	Wire feed roller for steel wires.....	47
10.1.1.2	Wire feed rollers for aluminium wires	47
10.1.2	4-roll drive	48
10.1.2.1	Wire feed roller for steel wires.....	48
10.1.2.2	Wire feed rollers for aluminium wires	48
11	Appendix A	49
11.1	Overview of EWM branches.....	49

2 Safety instructions

2.1 Notes on the use of these operating instructions

DANGER

Working or operating procedures which must be closely observed to prevent imminent serious and even fatal injuries.

- Safety notes include the "DANGER" keyword in the heading with a general warning symbol.
- The hazard is also highlighted using a symbol on the edge of the page.

WARNING

Working or operating procedures which must be closely observed to prevent serious and even fatal injuries.

- Safety notes include the "WARNING" keyword in the heading with a general warning symbol.
- The hazard is also highlighted using a symbol in the page margin.

CAUTION

Working or operating procedures which must be closely observed to prevent possible minor personal injury.

- The safety information includes the "CAUTION" keyword in its heading with a general warning symbol.
- The risk is explained using a symbol on the edge of the page.

CAUTION

Working and operating procedures which must be followed precisely to avoid damaging or destroying the product.

- The safety information includes the "CAUTION" keyword in its heading without a general warning symbol.
- The hazard is explained using a symbol at the edge of the page.

NOTE













Special technical points which users must observe.

- Notes include the "NOTE" keyword in the heading without a general warning symbol.

Instructions and lists detailing step-by-step actions for given situations can be recognised via bullet points, e.g.:

- Insert the welding current lead socket into the relevant socket and lock.

2.2 Explanation of icons

Symbol	Description
	Press
	Do not press
	Turn
	Switch
	Switch off machine
	Switch on machine
	ENTER (enter the menu)
	NAVIGATION (Navigating in the menu)
	EXIT (Exit the menu)
	Time display (example: wait 4s/press)
	Interruption in the menu display (other setting options possible)
	Tool not required/do not use
	Tool required/use

2.3 General

DANGER



Electromagnetic fields!

The power source may cause electrical or electromagnetic fields to be produced which could affect the correct functioning of electronic equipment such as IT or CNC devices, telecommunication lines, power cables, signal lines and pacemakers.

- Observe the maintenance instructions! (see Maintenance and Testing chapter)
- Unwind welding leads completely!
- Shield devices or equipment sensitive to radiation accordingly!
- The correct functioning of pacemakers may be affected (obtain advice from a doctor if necessary).



Do not carry out any unauthorised repairs or modifications!

To avoid injury and equipment damage, the unit must only be repaired or modified by specialist, skilled persons!

The warranty becomes null and void in the event of unauthorised interference.

- Appoint only skilled persons for repair work (trained service personnel)!



Electric shock!

Welding machines use high voltages which can result in potentially fatal electric shocks and burns on contact. Even low voltages can cause you to get a shock and lead to accidents.

- Do not touch any live parts in or on the machine!
- Connection cables and leads must be free of faults!
- Switching off alone is not sufficient!
- Place welding torch and stick electrode holder on an insulated surface!
- The unit should only be opened by specialist staff after the mains plug has been unplugged!
- Only wear dry protective clothing!
- Wait for 4 minutes until the capacitors have discharged!

WARNING



Risk of injury due to radiation or heat!

Arc radiation results in injury to skin and eyes.

Contact with hot workpieces and sparks results in burns.

- Use welding shield or welding helmet with the appropriate safety level (depending on the application)!
- Wear dry protective clothing (e.g. welding shield, gloves, etc.) according to the relevant regulations in the country in question!
- Protect persons not involved in the work against arc beams and the risk of glare using safety curtains!



Explosion risk!

Apparently harmless substances in closed containers may generate excessive pressure when heated.

- Move containers with inflammable or explosive liquids away from the working area!
- Never heat explosive liquids, dusts or gases by welding or cutting!

WARNING



Smoke and gases!

Smoke and gases can lead to breathing difficulties and poisoning. In addition, solvent vapour (chlorinated hydrocarbon) may be converted into poisonous phosgene due to the ultraviolet radiation of the arc!

- Ensure that there is sufficient fresh air!
- Keep solvent vapour away from the arc beam field!
- Wear suitable breathing apparatus if appropriate!



Fire hazard!

Flames may arise as a result of the high temperatures, stray sparks, glowing-hot parts and hot slag produced during the welding process.

Stray welding currents can also result in flames forming!

- Check for fire hazards in the working area!
- Do not carry any easily flammable objects such as matches or lighters.
- Keep appropriate fire extinguishing equipment to hand in the working area!
- Thoroughly remove any residue of flammable substances from the workpiece before starting welding.
- Only continue work on welded workpieces once they have cooled down.
Do not allow to come into contact with flammable material!
- Connect welding leads correctly!



Risk of accidents if these safety instructions are not observed!

Non-observance of these safety instructions is potentially fatal!

- Carefully read the safety information in this manual!
- Observe the accident prevention regulations in your country.
- Inform persons in the working area that they must observe the regulations!

CAUTION



Noise exposure!

Noise exceeding 70 dBA can cause permanent hearing damage!

- Wear suitable ear protection!
- Persons located within the working area must wear suitable ear protection!

CAUTION



Obligations of the operator!

The respective national directives and laws must be observed for operation of the machine!

- National implementation of the framework directive (89/391/EEG), as well as the associated individual directives.
- In particular, directive (89/655/EEG), on the minimum regulations for safety and health protection when staff members use equipment during work.
- The regulations regarding work safety and accident prevention for the respective country.
- Setting up and operating the machine according to IEC 60974-9.
- Check at regular intervals that users are working in a safety-conscious way.
- Regular checks of the machine according to IEC 60974-4.

CAUTION**Damage due to the use of non-genuine parts!****The manufacturer's warranty becomes void if non-genuine parts are used!**

- Only use system components and options (power sources, welding torches, electrode holders, remote controls, spare parts and replacement parts, etc.) from our range of products!
- Only insert and lock accessory components into the relevant connection socket when the machine is switched off.

**Damage to the machine due to stray welding currents!****Stray welding currents can destroy protective earth conductors, damage equipment and electronic devices and cause overheating of components leading to fire.**

- Make sure all welding leads are securely connected and check regularly.
- Always ensure a proper and secure electrical connection to the workpiece!
- Set up, attach or suspend all conductive power source components like casing, transport vehicle and crane frames so they are insulated!
- Do not place any other electronic devices such as drillers or angle grinders, etc., on the power source, transport vehicle or crane frames unless they are insulated!
- Always put welding torches and electrode holders on an insulated surface when they are not in use!

**Mains connection****Requirements for connection to the public mains network**

High-performance machines can influence the mains quality by taking current from the mains network. For some types of machines, connection restrictions or requirements relating to the maximum possible line impedance or the necessary minimum supply capacity at the interface with the public network (Point of Common Coupling, PCC) can therefore apply. In this respect, attention is also drawn to the machines' technical data. In this case, it is the responsibility of the operator, where necessary in consultation with the mains network operator, to ensure that the machine can be connected.

CAUTION



EMC Machine Classification

In accordance with IEC 60974-10, welding machines are grouped in two electromagnetic compatibility classes (see technical data):

Class A machines are not intended for use in residential areas where the power supply comes from the low-voltage public mains network. When ensuring the electromagnetic compatibility of class A machines, difficulties can arise in these areas due to interference not only in the supply lines but also in the form of radiated interference.

Class B machines fulfil the EMC requirements in industrial as well as residential areas, including residential areas connected to the low-voltage public mains network.

Setting up and operating

When operating arc welding systems, in some cases, electro-magnetic interference can occur although all of the welding machines comply with the emission limits specified in the standard. The user is responsible for any interference caused by welding.

In order to **evaluate** any possible problems with electromagnetic compatibility in the surrounding area, the user must consider the following: (see also EN 60974-10 Appendix A)

- Mains, control, signal and telecommunication lines
- Radios and televisions
- Computers and other control systems
- Safety equipment
- The health of neighbouring persons, especially if they have a pacemaker or wear a hearing aid
- Calibration and measuring equipment
- The immunity to interference of other equipment in the surrounding area
- The time of day at which the welding work must be carried out

Recommendations for reducing interference emission

- Mains connection, e.g. additional mains filter or shielding with a metal tube
- Maintenance of the arc welding equipment
- Welding leads should be as short as possible and run closely together along the ground
- Potential equalization
- Earthing of the workpiece. In cases where it is not possible to earth the workpiece directly, it should be connected by means of suitable capacitors.
- Shielding from other equipment in the surrounding area or the entire welding system

2.4 Transport and installation

WARNING



Incorrect handling of shielding gas cylinders!

Incorrect handling of shielding gas cylinders can result in serious and even fatal injury.

- Observe the instructions from the gas manufacturer and in any relevant regulations concerning the use of compressed air!
- Place shielding gas cylinders in the holders provided for them and secure with fixing devices.
- Avoid heating the shielding gas cylinder!



Risk of accident due to improper transport of machines that may not be lifted!

Do not lift or suspend the machine! The machine can fall down and cause injuries! The handles and brackets are suitable for transport by hand only!

- The machine may not be lifted by crane or suspended!

CAUTION



Risk of tipping!

There is a risk of the machine tipping over and injuring persons or being damaged itself during movement and set up. Tilt resistance is guaranteed up to an angle of 10° (according to EN 60974-A2).

- Set up and transport the machine on level, solid ground!
- Secure add-on parts using suitable equipment!
- Replace damaged wheels and their fixing elements!
- Fix external wire feed units during transport (avoid uncontrolled rotation)!



Damage due to supply lines not being disconnected!

During transport, supply lines which have not been disconnected (mains supply leads, control leads, etc.) may cause hazards such as connected equipment tipping over and injuring persons!

- Disconnect supply lines!

CAUTION



Equipment damage when not operated in an upright position!

The units are designed for operation in an upright position!

Operation in non-permissible positions can cause equipment damage.

- Only transport and operate in an upright position!

2.5 Ambient conditions

CAUTION



Installation site!

The machine must not be operated in the open air and must only be set up and operated on a suitable, stable and level base!

- The operator must ensure that the ground is non-slip and level, and provide sufficient lighting for the place of work.
- Safe operation of the machine must be guaranteed at all times.

CAUTION



Equipment damage due to dirt accumulation!

Unusually high quantities of dust, acid, corrosive gases or substances may damage the equipment.

- Avoid high volumes of smoke, vapour, oil vapour and grinding dust!
- Avoid ambient air containing salt (sea air)!



Non-permissible ambient conditions!

Insufficient ventilation results in a reduction in performance and equipment damage.

- Observe the ambient conditions!
- Keep the cooling air inlet and outlet clear!
- Observe the minimum distance of 0.5 m from obstacles!

2.5.1 In operation

Temperature range of the ambient air:

- -20 °C to +40 °C

Relative air humidity:

- Up to 50% at 40 °C
- Up to 90% at 20 °C

2.5.2 Transport and storage

Storage in an enclosed space, temperature range of the ambient air:

- -25 °C to +55 °C

Relative air humidity

- Up to 90% at 20 °C

3 Intended use

WARNING



Hazards due to improper usage!

Hazards may arise for persons, animals and material objects if the equipment is not used correctly. No liability is accepted for any damages arising from improper usage!

- The equipment must only be used in line with proper usage and by trained or expert staff!
- Do not modify or convert the equipment improperly!

3.1 Applications

3.1.1 MIG/MAG standard welding

Metal arc welding using a wire electrode whereby gas from an external source surrounds the arc and the molten pool to protect them from the atmosphere.

3.2 Overview of device types

3.2.1 Multi-voltage machine (MV)

MV series machines can be adapted to e.g. the mains voltages of different countries (for supported mains voltages refer to the Technical data chapter).

3.3 Documents which also apply

3.3.1 Warranty

NOTE



For further information, please see the accompanying supplementary sheets "Machine and Company Data, Maintenance and Testing, Warranty"!

3.3.2 Declaration of Conformity



The designated machine conforms to EC Directives and standards in terms of its design and construction:

- EC Low Voltage Directive (2006/95/EC),
- EC EMC Directive (2004/108/EC),

This declaration shall become null and void in the event of unauthorised modifications, improperly conducted repairs, non-observance of the deadlines for the repetition test and / or non-permitted conversion work not specifically authorised by the manufacturer.

The original copy of the declaration of conformity is enclosed with the unit.

3.3.3 Welding in environments with increased electrical hazards



In compliance with IEC / DIN EN 60974, VDE 0544 the machines can be used in environments with an increased electrical hazard.

3.3.4 Service documents (spare parts and circuit diagrams)



DANGER



Do not carry out any unauthorised repairs or modifications!

To avoid injury and equipment damage, the unit must only be repaired or modified by specialist, skilled persons!

The warranty becomes null and void in the event of unauthorised interference.

- Appoint only skilled persons for repair work (trained service personnel)!

Original copies of the circuit diagrams are enclosed with the unit.

Spare parts can be obtained from the relevant authorised dealer.

4 Machine description – quick overview

4.1 Front view

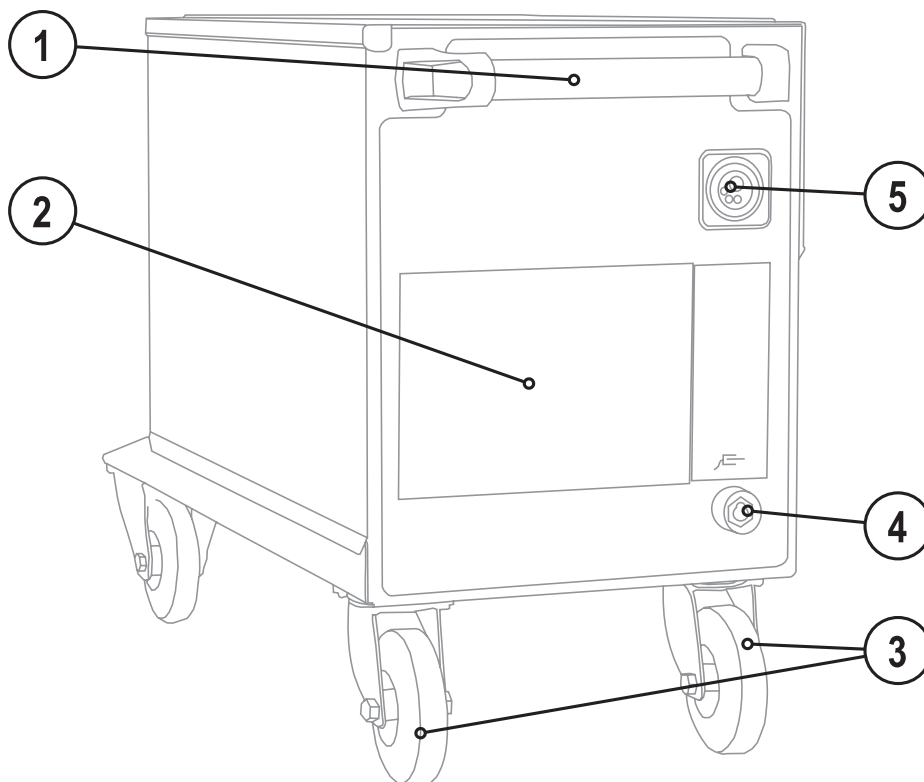

Figure 4-1

Item	Symbol	Description
1		Carrying handle
2		Machine control See Machine control – operating elements chapter
3		Wheels, guide castors
4		Connection socket, workpiece lead
5		Central connection for welding torch (Euro) Integrated welding current, shielding gas and torch trigger

4.2 Rear view

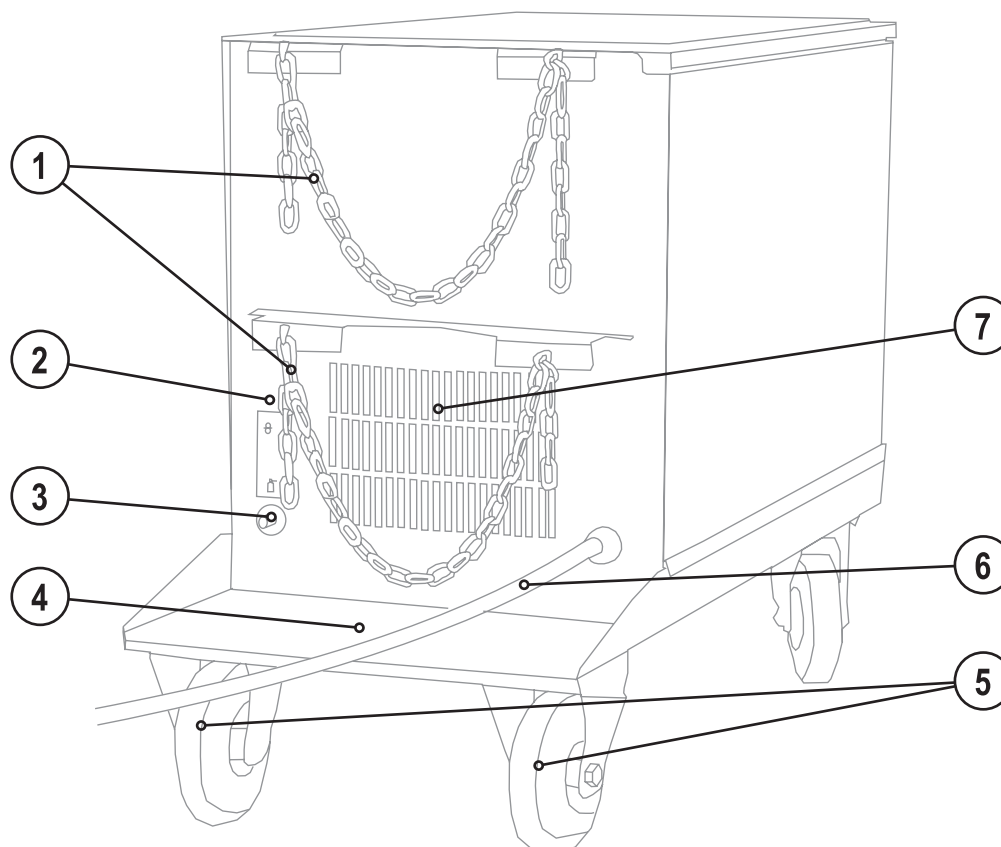

Figure 4-2

Item	Symbol	Description
1		Securing elements for shielding gas cylinder (strap/chain)
2		Key button, Automatic cutout Wire feed motor supply voltage fuse (press to reset a triggered fuse)
3		Connecting nipple G¹/₄, shielding gas connection
4		Bracket for shielding gas cylinder
5		Wheels, fixed castors
6		Mains connection cable
7		Cooling air inlet

4.2.1 Inside view

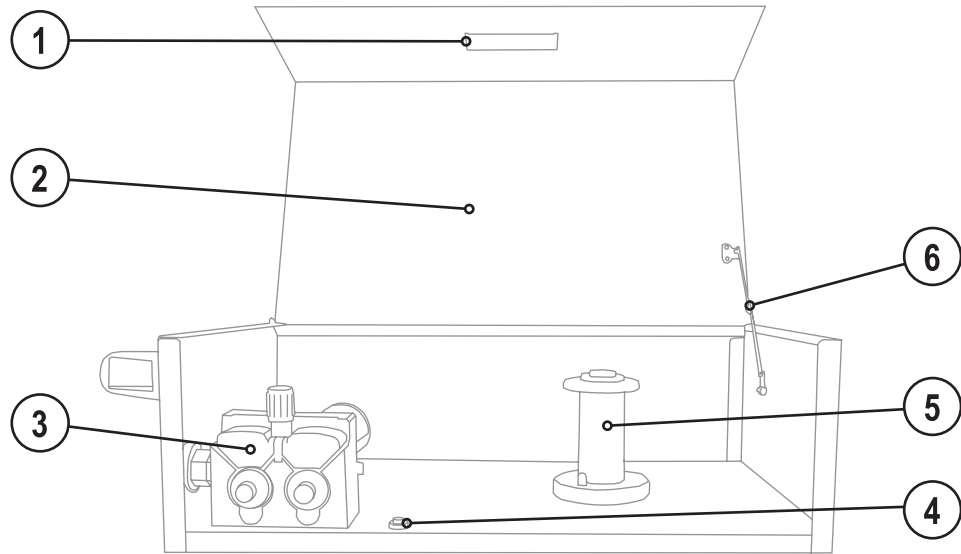

Figure 4-3

Item	Symbol	Description
1		Inspection window for checking the wire and handle for opening the cover
2		Wire delivery unit cover
3		Wire feed unit
4		Wire inching button
5		Wire spool holder
6		Flap support

4.3 Machine control – Operating elements

4.3.1 Mira 151

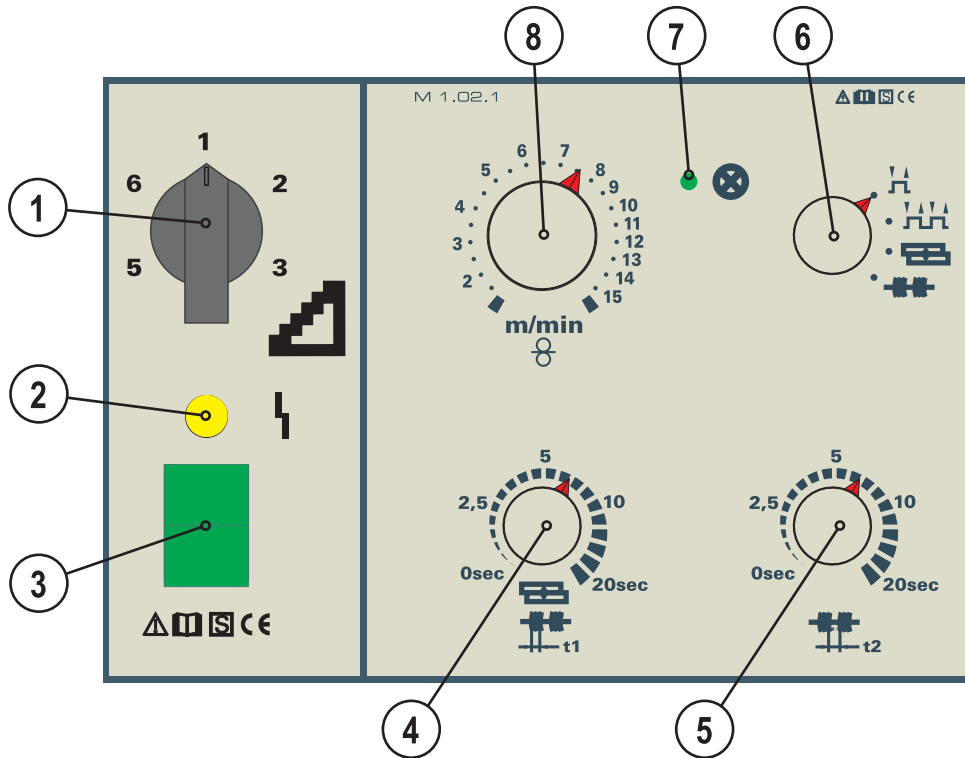

Figure 4-4

Item	Symbol	Description
1		Step switch, welding voltage
2		Signal light, Functional error On when excess temperature detected
3		Main switch, machine on/off
4		Rotary dial, Spot and interval times Infinite adjustment of the welding time (0-20s) in "Spots and interval" operating mode
5		Rotary dial, Pause time Infinite adjustment of the pause time (0-20s) in "Interval" operating mode
6		"Operating mode" selector switch Changeover between non-latched, latched, spot, interval
7		Ready for operation signal light Signal light on when the machine is switched on and ready for operation
8		"Wire speed setting" rotary dial Infinite adjustment of the wire speed.

4.3.2 Mira 221 MV

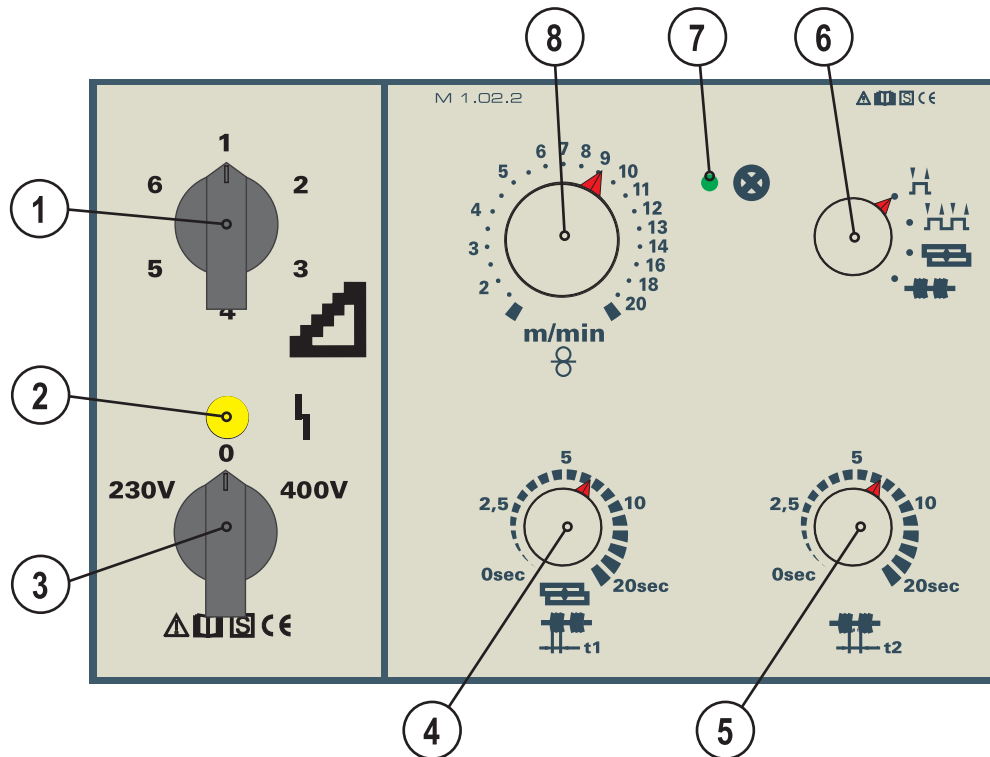

Figure 4-5

Item	Symbol	Description
1		Step switch, welding voltage
2		Signal light, Functional error On when excess temperature detected
3		Main switch, alternate 230V/Off/400V 230V position Machine switched on (with 1 x 230V mains connection) Position 0 Machine switched off 400V position Machine switched on (with 2 x 400V mains connection)
4		Rotary dial, Spot and interval times Infinite adjustment of the welding time (0-20s) in "Spots and interval" operating mode
5		Rotary dial, Pause time Infinite adjustment of the pause time (0–20s) in "Interval" operating mode
6		"Operating mode" selector switch Changeover between non-latched, latched, spot, interval
7		Ready for operation signal light Signal light on when the machine is switched on and ready for operation
8		"Wire speed setting" rotary dial Infinite adjustment of the wire speed.

4.3.3 Mira 251

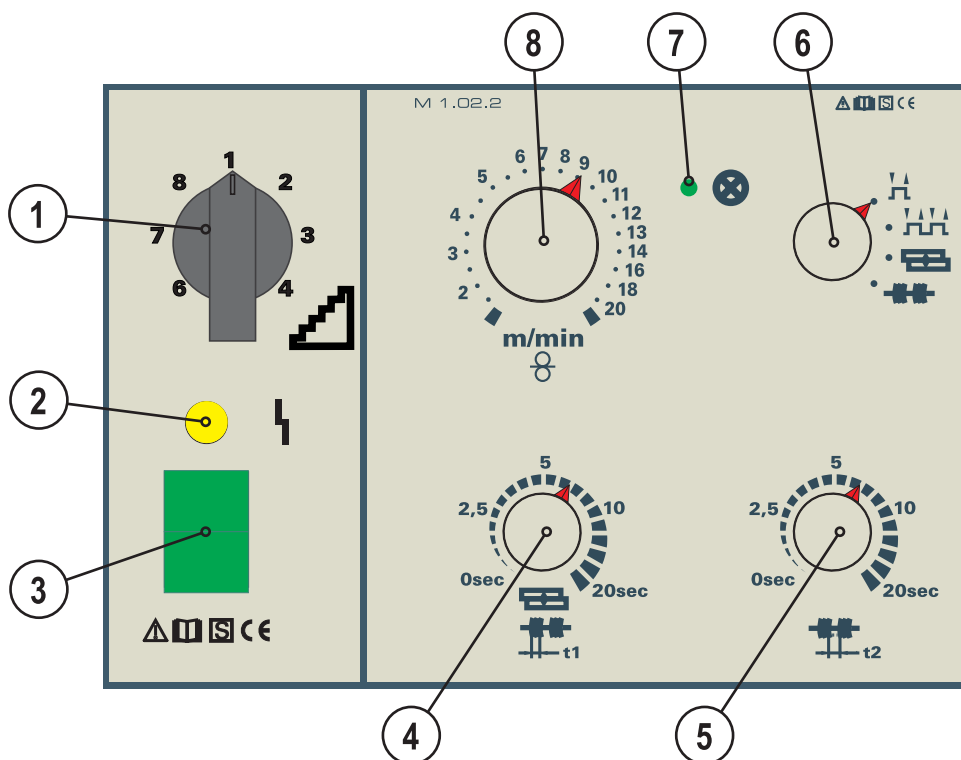

Figure 4-6

Item	Symbol	Description
1		Step switch, welding voltage
2		Signal light, Functional error On when excess temperature detected
3		Main switch, machine on/off
4		Rotary dial, Spot and interval times Infinite adjustment of the welding time (0-20s) in "Spots and interval" operating mode
5		Rotary dial, Pause time Infinite adjustment of the pause time (0-20s) in "Interval" operating mode
6		"Operating mode" selector switch Changeover between non-latched, latched, spot, interval
7		Ready for operation signal light Signal light on when the machine is switched on and ready for operation
8		"Wire speed setting" rotary dial Infinite adjustment of the wire speed.

4.3.4 Mira 301

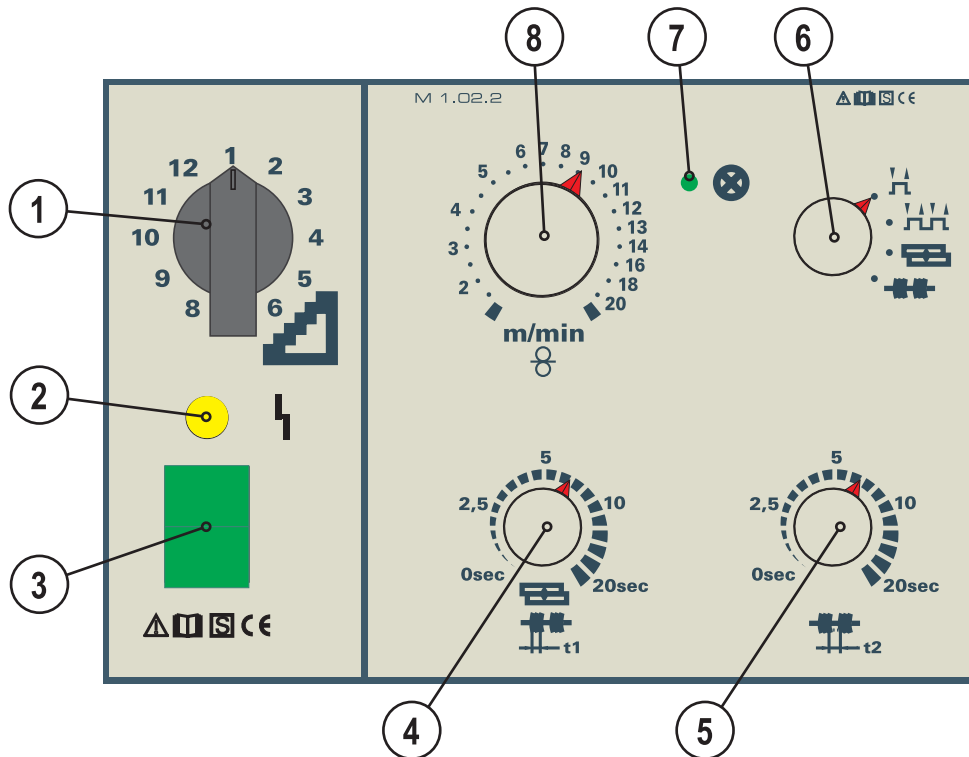

Figure 4-7

Item	Symbol	Description
1		Step switch, welding voltage
2		Signal light, Functional error On when excess temperature detected
3		Main switch, machine on/off
4		Rotary dial, Spot and interval times Infinite adjustment of the welding time (0-20s) in "Spots and interval" operating mode
5		Rotary dial, Pause time Infinite adjustment of the pause time (0-20s) in "Interval" operating mode
6		"Operating mode" selector switch Changeover between non-latched, latched, spot, interval
7		Ready for operation signal light Signal light on when the machine is switched on and ready for operation
8		"Wire speed setting" rotary dial Infinite adjustment of the wire speed.

5 Design and function

5.1 General

WARNING



Risk of injury from electric shock!

Contact with live parts, e.g. welding current sockets, is potentially fatal!

- Follow safety instructions on the opening pages of the operating instructions.
- Commissioning may only be carried out by persons who have the relevant expertise of working with arc welding machines!
- Connection and welding leads (e.g. electrode holder, welding torch, workpiece lead, interfaces) may only be connected when the machine is switched off!

CAUTION



Risk of burns on the welding current connection!

If the welding current connections are not locked, connections and leads heat up and can cause burns, if touched!

- Check the welding current connections every day and lock by turning in clockwise direction, if necessary.



Risk of injury due to moving parts!

The wire feed units are equipped with moving parts, which can trap hands, hair, clothing or tools and thus injure persons!

- Do not reach into rotating or moving parts or drive components!
- Keep casing covers closed during operation!



Risk of injury due to welding wire escaping in an unpredictable manner!

Welding wire can be conveyed at very high speeds and, if conveyed incorrectly, may escape in an uncontrolled manner and injure persons!

- Before mains connection, set up the complete wire guide system from the wire spool to the welding torch!
- Remove the pressure rollers from the wire feed unit if no welding torch is fitted!
- Check wire guide at regular intervals!
- Keep all casing covers closed during operation!



Risk from electrical current!

If welding is carried out alternately using different methods and if a welding torch and an electrode holder remain connected to the machine, the open-circuit/welding voltage is applied simultaneously on all cables.

- The torch and the electrode holder should therefore always be placed on an insulated surface before starting work and during breaks.

CAUTION**Damage due to incorrect connection!**

Accessory components and the power source itself can be damaged by incorrect connection!

- Only insert and lock accessory components into the relevant connection socket when the machine is switched off.
- Comprehensive descriptions can be found in the operating instructions for the relevant accessory components.
- Accessory components are detected automatically after the power source is switched on.

**Using protective dust caps!**

Protective dust caps protect the connection sockets and therefore the machine against dirt and damage.

- The protective dust cap must be fitted if there is no accessory component being operated on that connection.
- The cap must be replaced if faulty or if lost!

5.2 Installation

**WARNING**

Risk of accident due to improper transport of machines that may not be lifted!

Do not lift or suspend the machine! The machine can fall down and cause injuries! The handles and brackets are suitable for transport by hand only!

- The machine may not be lifted by crane or suspended!

**CAUTION****Installation site!**

The machine must not be operated in the open air and must only be set up and operated on a suitable, stable and level base!

- The operator must ensure that the ground is non-slip and level, and provide sufficient lighting for the place of work.
- Safe operation of the machine must be guaranteed at all times.

5.3 Machine cooling

To obtain an optimal duty cycle from the power components, the following precautions should be observed:

- Ensure that the working area is adequately ventilated.
- Do not obstruct the air inlets and outlets of the machine.
- Do not allow metal parts, dust or other objects to get into the machine.

5.4 Workpiece lead, general

**CAUTION**

Risk of burns due to incorrect connection of the workpiece lead!

Paint, rust and dirt on the connection restrict the power flow and may lead to stray welding currents.

Stray welding currents may cause fires and injuries!

- Clean the connections!
- Fix the workpiece lead securely!
- Do not use structural parts of the workpiece as a return lead for the welding current!
- Take care to ensure faultless power connections!

5.5 Mains connection

DANGER



Hazard caused by improper mains connection!

An improper mains connection can cause injuries or damage property!

- Only use machine with a plug socket that has a correctly fitted protective conductor.
- If a mains plug must be fitted, this may only be carried out by an electrician in accordance with the relevant national provisions or regulations (any phase sequence for three-phase machines)!
- Mains plug, socket and lead must be checked regularly by an electrician!
- When operating the generator always ensure it is earthed as stated in the operating instructions. The resulting network has to be suitable for operating devices according to protection class 1.

CAUTION



Operating voltage - mains voltage!

The operating voltage shown on the rating plate must be consistent with the mains voltage, in order to avoid damage to the machine!

- For mains fuse protection, please refer to the "Technical data" chapter!

NOTE



Before connecting to the mains network and before disconnecting from the mains network:

- Move the mains switch to the "0" position

5.6 Mira 151

NOTE



The machine may be connected and operated on all TN or TT networks with a neutral conductor and a protective conductor.

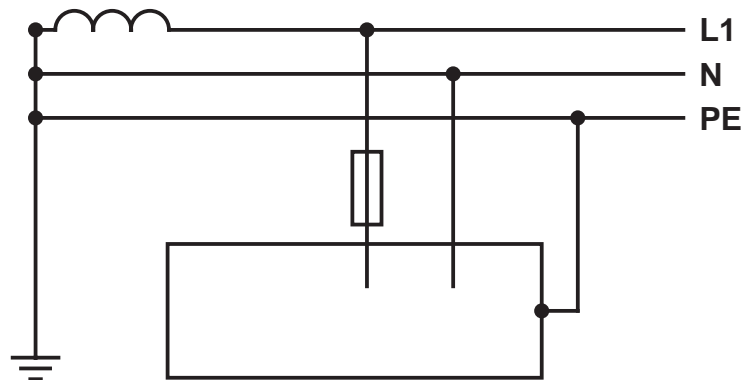

Figure 5-1

Legend

Item	Designation	Colour code
L1	Outer conductor	brown
N	Neutral conductor	blue
PE	Protective conductor	green-yellow

- Insert mains plug of the switched-off machine into the appropriate socket.

5.6.1 Mira 221 MV

5.6.1.1 Connection with 230 V mains voltage

NOTE

- Use the "CEE16/SHOCK-PROOF" adapter provided to connect to the 230V mains power.
- The machine may be connected and operated on all TN or TT networks with a neutral conductor and a protective conductor.

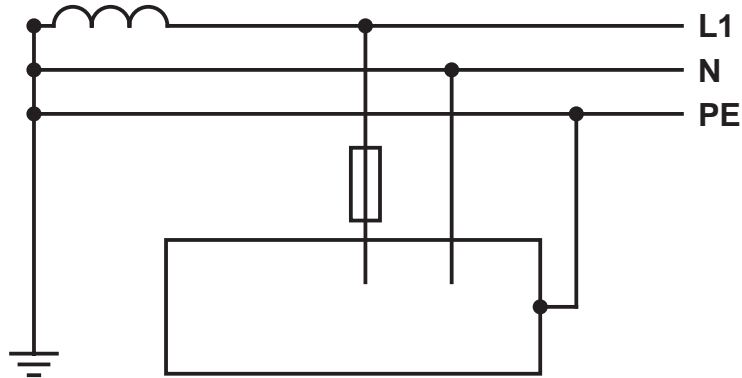
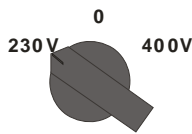

Figure 5-2

Legend

Item	Designation	Colour code
L1	Outer conductor	brown
N	Neutral conductor	blue
PE	Protective conductor	green-yellow

- Insert mains plug of the switched-off machine into the appropriate socket.



Switching on with mains connection on the 230V mains network

Position 0V	Machine switched off
Position 230V	Machine switched on
Position 400V	Machine switched off

5.6.1.2 Connection with 400 V mains voltage

NOTE



The machine may be connected to TN, TT or IT networks with a protective conductor (as available).

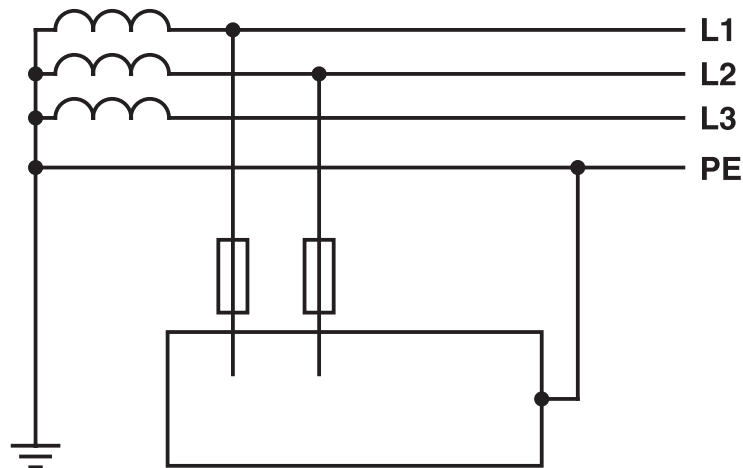
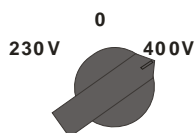

Figure 5-3

Legend

Item	Designation	Colour code
L1	Outer conductor 1	black
L2	Outer conductor 2	brown
L3	Outer conductor 3	-
PE	Protective conductor	green-yellow

- Insert mains plug of the switched-off machine into the appropriate socket.



Switching on with mains connection on the 400V mains network

Position 0V	Machine switched off
Position 230V	Machine switched off
Position 400V	Machine switched on

5.6.2 Mira 251, 301

NOTE

The machine may be connected to TN, TT or IT networks with a protective conductor (as available).

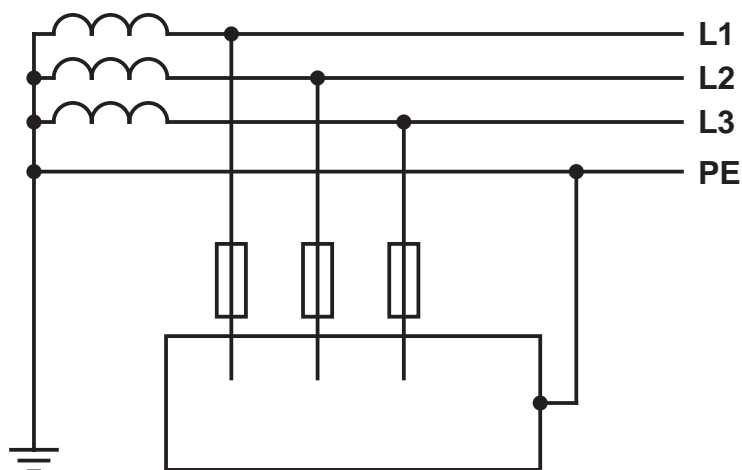

Figure 5-4

Legend

Item	Designation	Colour code
L1	Outer conductor 1	black
L2	Outer conductor 2	brown
L3	Outer conductor 3	grey
PE	Protective conductor	green-yellow

- Insert mains plug of the switched-off machine into the appropriate socket.

5.7 Welding torch and workpiece line connection

Depending on the wire electrode diameter or type, either a spiral guide or plastic core with the correct inner diameter has to be inserted in the torch!

Recommendation:

- Use a spiral guide to weld hard, unalloyed wire electrodes (steel).
- Use a plastic core to weld or braze soft, high-alloy wire electrodes or aluminium materials.

NOTE



Fault with the wire guide!

On delivery, the central connector (Euro) is fitted with a capillary tube for welding torches with spiral guides. Conversion is necessary if a welding torch with a plastic core is used!

Welding torch with plastic core:

- use with guide tube!

Welding torch with spiral guide:

- use with capillary tube!

Preparation work for connecting welding torches with a plastic core:

- Push forward the capillary tube on the wire feed side in the direction of the central connector and remove there.
- Slide plastic core support tube off the central connector.
- Carefully insert the central plug for the welding torch, with the still oversized plastic core, into the central connector and screw together with crown nut.
- Use a suitable tool to cut off the plastic core shortly before the wire feed roller, making sure not to pinch it.
- Unfasten and remove the central plug on the welding torch.
- Cleanly remove the burr from the separated end of the plastic core!

NOTE



Preparation work for connecting welding torches with a spiral guide:

- Check that the capillary tube is correctly positioned in relation to the central connector!

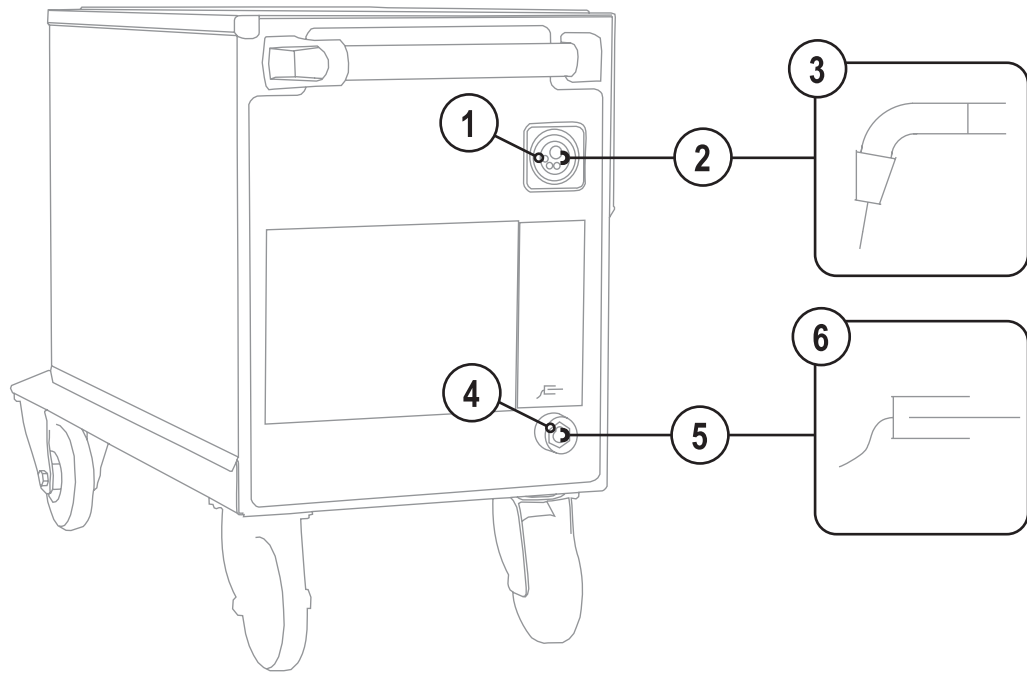

Figure 5-5

Item	Symbol	Description
1		Central connection for welding torch (Euro) Integrated welding current, shielding gas and torch trigger
2		Welding torch hose package
3		Welding torch
4		Connection socket, workpiece lead
5		Workpiece lead
6		Workpiece

- Insert the central plug for the welding torch into the central connector and screw together with crown nut.
- Insert cable plug on the workpiece lead into the connection socket for workpiece lead and lock by turning to the right.

5.8 Shielding gas supply

WARNING



Risk of accident by exceeding the maximum size of the gas cylinder!

Maximum permissible shielding gas cylinder size at fill pressure. Exceeding these limits can cause the loss of steadiness up to an angle of 10° (IEC 60974-2). This can cause injuries.

- max. 20 litres geometric volume at 200 bar fill pressure.



Incorrect handling of shielding gas cylinders!

Incorrect handling of shielding gas cylinders can result in serious and even fatal injury.

- Observe the instructions from the gas manufacturer and in any relevant regulations concerning the use of compressed air!
- Place shielding gas cylinders in the holders provided for them and secure with fixing devices.
- Avoid heating the shielding gas cylinder!

CAUTION



Faults in the shielding gas supply.

An unhindered shielding gas supply from the shielding gas cylinder to the welding torch is a fundamental requirement for optimum welding results. In addition, a blocked shielding gas supply may result in the welding torch being destroyed.

- Always re-fit the yellow protective cap when not using the shielding gas connection.
- All shielding gas connections must be gas tight.

NOTE



Before connecting the pressure regulator to the gas cylinder, open the cylinder valve briefly to expel any dirt.

5.8.1 Connecting the shielding gas supply

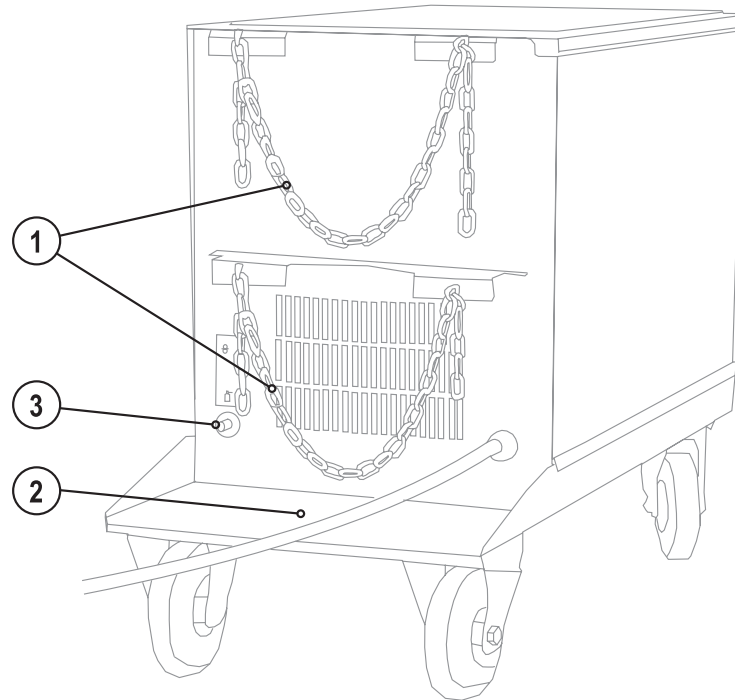



Figure 5-6

Item	Symbol	Description
1		Securing elements for shielding gas cylinder (strap/chain)
2		Bracket for shielding gas cylinder
3		Connecting nipple G $\frac{1}{4}$ ", shielding gas connection

- Place the shielding gas cylinder into the relevant cylinder bracket.
- Secure the shielding gas cylinder using a securing chain.
- Screw the gas hose connection nipple onto the G $\frac{1}{4}$ " connection nipple.

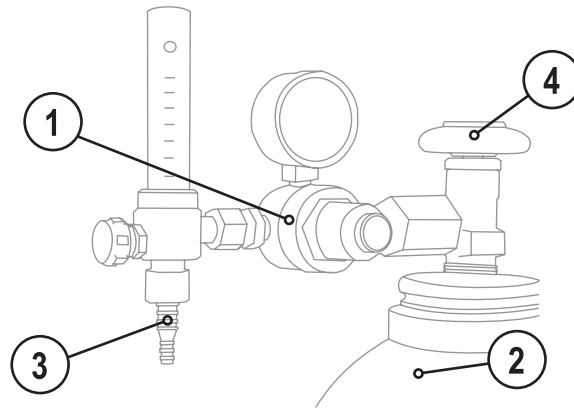

Figure 5-7

Item	Symbol	Description
1		Pressure regulator
2		Shielding gas cylinder
3		Output side of the pressure regulator
4		Cylinder valve

- Tighten the pressure regulator screw connection on the gas bottle valve to be gas-tight.
- Screw gas hose connection crown nut onto the output side of the pressure regulator.

5.8.2 Setting the shielding gas quantity

Welding process	Recommended shielding gas quantity
MAG welding	Wire diameter x 11.5 = l/min
MIG brazing	Wire diameter x 11.5 = l/min
MIG welding (aluminium)	Wire diameter x 13.5 = l/min (100 % argon)
TIG	Gas nozzle diameter in mm corresponds to l/min gas throughput

Helium-rich gas mixtures require a higher gas volume!

The table below can be used to correct the gas volume calculated where necessary:

Shielding gas	Factor
75% Ar/25% He	1.14
50% Ar/50% He	1.35
25% Ar/75% He	1.75
100% He	3.16

NOTE



Incorrect shielding gas setting!

If the shielding gas setting is too low or too high, this can introduce air to the weld pool and may cause pores to form.

- Adjust the shielding gas quantity to suit the welding task!

5.9 Inserting the wire electrode

5.9.1 Inserting the wire spool

NOTE

 Standard D300 wire spool holder can be used. Adapters (see accessories) are required when using standardised basket coils (DIN 8559).

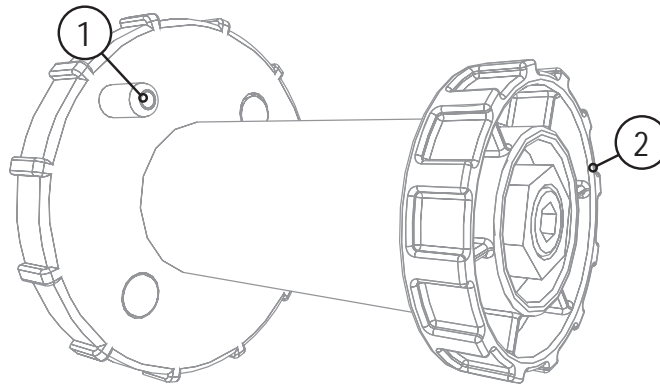

Figure 5-8

Item	Symbol	Description
1		Carrier pin For fixing the wire spool
2		Knurled nut For fixing the wire spool

- Loosen knurled nut from spool holder.
- Fix welding wire reel onto the spool holder so that the carrier pin locks into the spool bore.
- Fasten wire spool using knurled nut.

CAUTION



Risk of injury due to incorrectly secured wire spool.

If the wire spool is not secured properly, it may come loose from the wire spool holder and fall to the ground, causing damage to the machine and injuries.

- Securely fasten the wire spool to the wire spool holder using the knurled nut.
- Before you start working, always check the wire spool is securely fastened.

5.9.2 Changing the wire feed rollers

NOTE



Unsatisfactory welding results due to faulty wire feeding!

Wire feed rollers must be suitable for the diameter of the wire and the material.

- Check the roller label to verify that the rollers are suitable for the wire diameter. Turn or change if necessary!
- use V-groove rollers with for steel wires and other hard wires,
- use U-groove rollers for aluminium wires and other soft, alloyed wires.

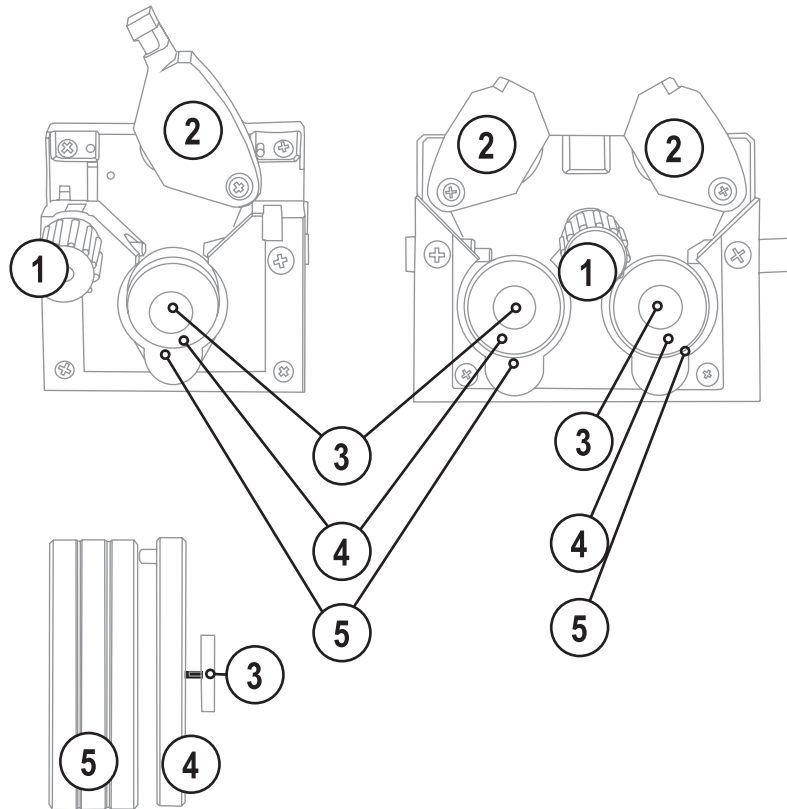

Figure 5-9

Item	Symbol	Description
1		Pressure units
2		Clamping units
3		Knurled screws
4		Driver plate
5		Drive rollers

- Unfasten pressure units and fold out (clamping units and pressure rollers will automatically flip upwards).
- Unfasten and remove knurled screws
- Remove the drive rollers together with the driver plates.
- Slide new drive roller onto driver plate.
- Assemble by following these steps in the reverse order

NOTE

The welding wire is fed into the rear groove on the wire roll!

- Labels relate to the rear groove on the wire roll when installed.

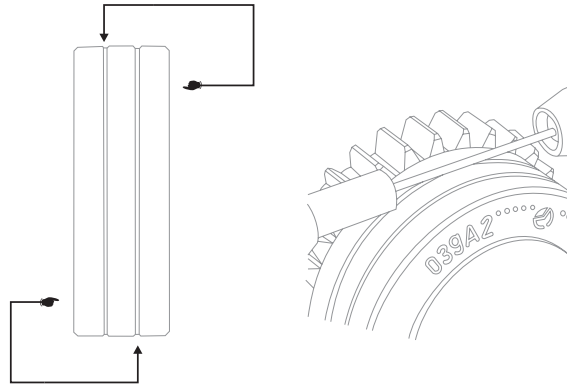

Figure 5-10

5.9.3 Inching the wire electrode

**CAUTION**

Risk of injury due to moving parts!

The wire feed units are equipped with moving parts, which can trap hands, hair, clothing or tools and thus injure persons!

- Do not reach into rotating or moving parts or drive components!
- Keep casing covers closed during operation!



Risk of injury due to welding wire escaping in an unpredictable manner!

Welding wire can be conveyed at very high speeds and, if conveyed incorrectly, may escape in an uncontrolled manner and injure persons!

- Before mains connection, set up the complete wire guide system from the wire spool to the welding torch!
- Remove the pressure rollers from the wire feed unit if no welding torch is fitted!
- Check wire guide at regular intervals!
- Keep all casing covers closed during operation!

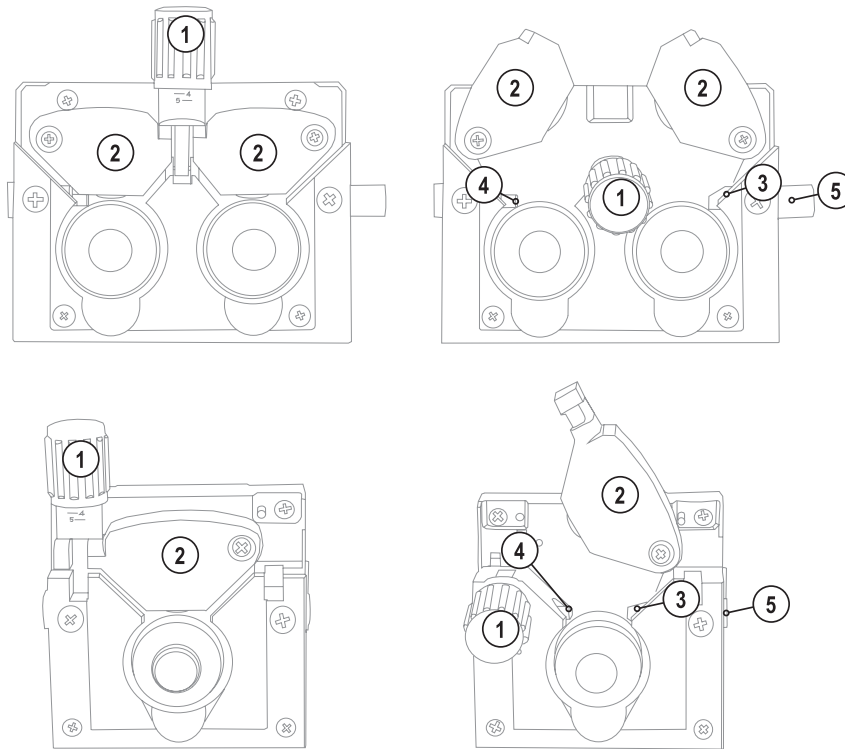

Figure 5-11

Item	Symbol	Description
1		Pressure units
2		Clamping units
3		Wire feed nipple
4		Capillary tube or plastic core with support tube, depending on the torch equipment

- Extend and lay out the torch tube package.
- Unfasten and fold up the pressure unit. Clamping units will fold up automatically.
- Carefully unwind the wire electrode from the wire spool and insert through the wire feed nipple via the rear groove on the drive roller into the capillary tube or plastic core with support tube.
- Push the clamping units downwards and fold the pressure unit back up. The wire electrode must be located in the groove on the drive roller.

CAUTION



Extensive wear due to incorrect contact pressure!

Incorrect contact pressure will cause extensive wear of the wire feed rollers!

- With the adjusting nuts of the pressure units set the contact pressure so that the wire electrode is conveyed but will still slip through if the wire spool jams.
- Set the contact pressure of the front rollers (in wire feed direction) to a higher value!

- Press the wire inching button until the wire electrode projects out of the welding torch.

5.9.4 Spool brake setting

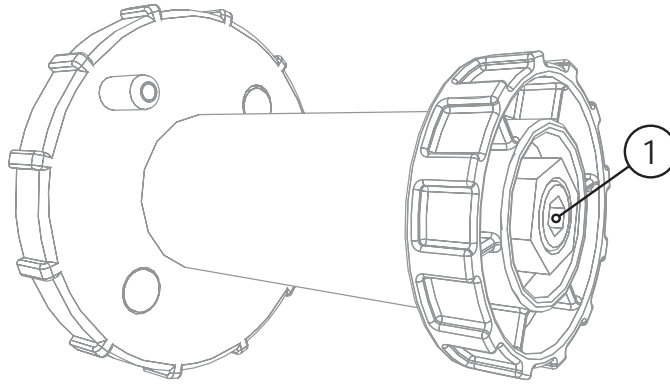

Figure 5-12

Item	Symbol	Description
1		Allen screw Securing the wire spool retainer and adjustment of the spool brake

- Tighten the Allen screw (8 mm) in the clockwise direction to increase the braking effect.

NOTE

Tighten the spool brake until the wire spool no longer turns when the wire feed motor stops but without it jamming during operation!

5.9.5 MIG/MAG operating point

Operating element	Action	Result
		Select operating mode H non-latched HH latched □ spots or - - interval
		Wire speed setting
		Welding voltage setting

NOTE



It is not necessary to set other parameters.

The permanently set gas pre-flow time is 200ms. The wire burn-back time is automatically controlled by the machine control using the welding characteristics.

5.10 MIG/MAG functional sequences / operating modes

5.10.1 Explanation of signs and functions

Symbol	Meaning
	Press torch trigger
	Release torch trigger
	Shielding gas flowing
	Welding output
	Wire electrode is being conveyed
	Wire burn-back
	Gas pre-flows
	Non-latched
	Latched
	Time
	Spot time
	Interval pause

5.10.2 Non-latched operation

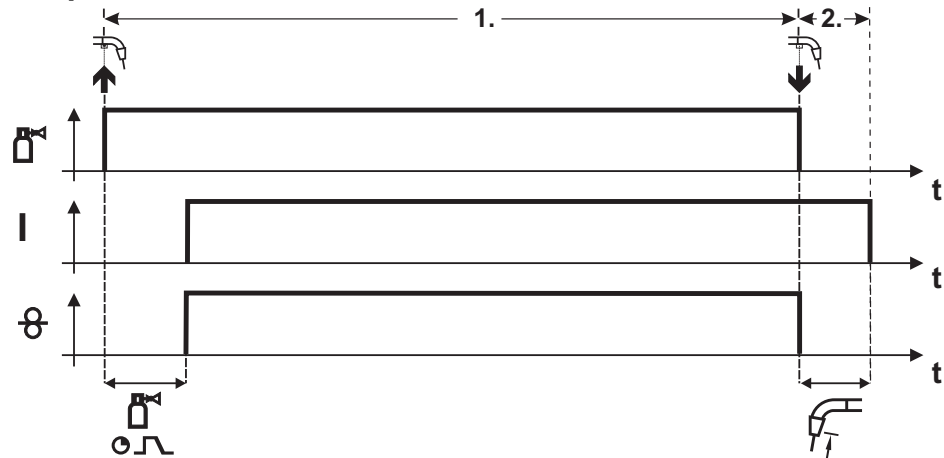

Figure 5-13

1st cycle

- Press and hold torch trigger.
- Shielding gas is expelled (gas pre-flows).
- Arc ignites after the wire electrode makes contact with the workpiece.
- Welding current flows.

2nd cycle

- Release torch trigger, wire feed motor stops, arc is extinguished.

5.10.3 Latched operation

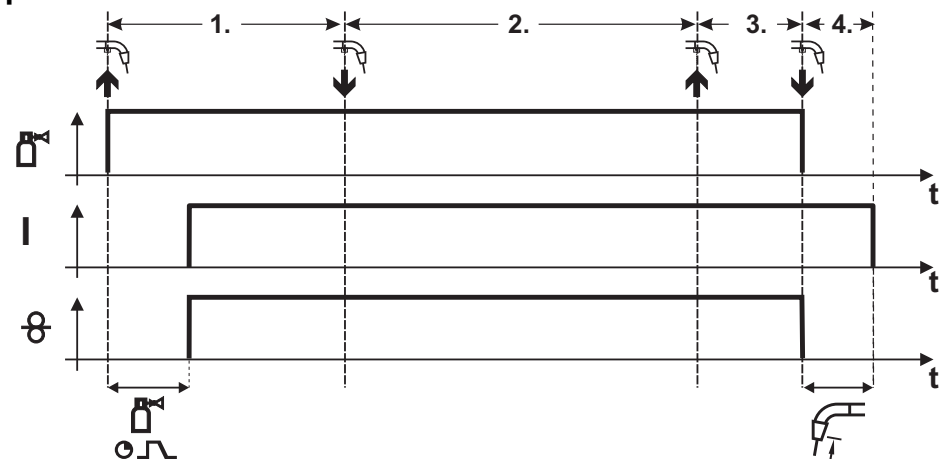

Figure 5-14

1st cycle

- Press and hold torch trigger.
- Shielding gas is expelled (gas pre-flows).
- Arc ignites after the wire electrode makes contact with the workpiece.
- Welding current flows.

2nd cycle

- Release torch trigger (no effect).

3rd cycle

- Press torch trigger (no effect).

4th cycle

- Release torch trigger, wire feed motor stops, arc is extinguished.

5.10.4 Spot welding

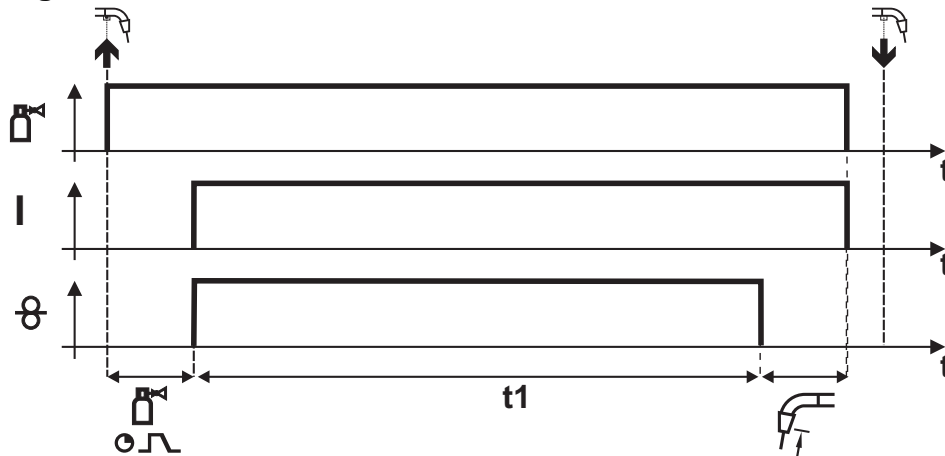

Figure 5-15

Start

- Press and hold torch trigger.
- Shielding gas is expelled (gas pre-flows).
- Arc ignites after the wire electrode makes contact with the workpiece.
- Welding current flows.
- The wire feed is stopped after the set stop time elapses, the arc is extinguished.

End early

- Release torch trigger.

5.10.5 Interval

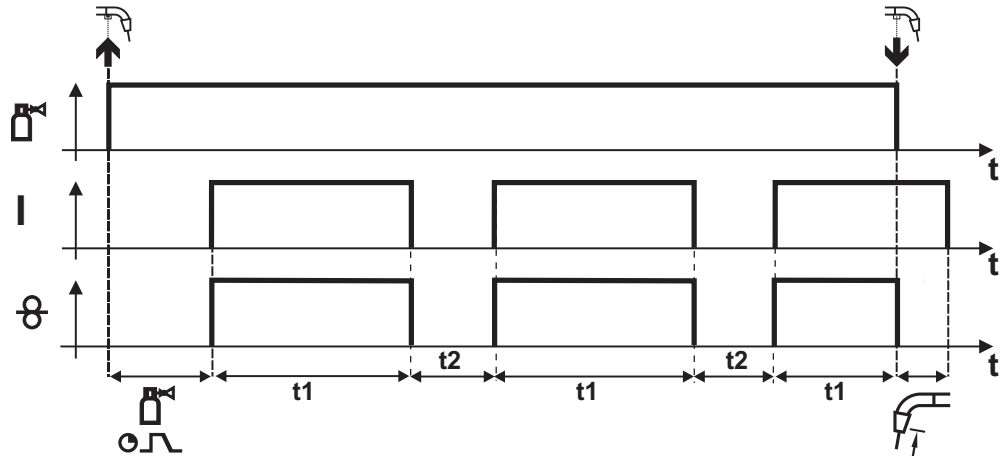

Figure 5-16

Start

- Press and hold torch trigger.
- Shielding gas is expelled (gas pre-flows).
- Arc ignites after the wire electrode makes contact with the workpiece.
- Welding current flows.
- The wire feed stops after the pulse time expires.
- Arc is extinguished.
- The process is repeated after the pause time elapses.

End

- Release torch trigger, wire feed stops, arc is extinguished.

NOTE

When the torch trigger is released, the welding process is also interrupted even before the spot time elapses.

6 Maintenance, care and disposal



DANGER



Risk of injury from electric shock!

Cleaning machines that are not disconnected from the mains can lead to serious injuries!

- Disconnect the machine completely from the mains.
- Remove the mains plug!
- Wait for 4 minutes until the capacitors have discharged!

6.1 General

When used in the specified environmental conditions and under normal operating conditions, this machine is largely maintenance-free and requires a minimum of care.

There are some points, which should be observed, to guarantee fault-free operation of your welding machine. Among these are regular cleaning and checking as described below, depending on the pollution level of the environment and the length of time the unit is in use.

6.2 Maintenance work, intervals

6.2.1 Daily maintenance tasks

- Check correct mounting of the wire spool.
- Mains supply lead and its strain relief
- Welding current cables (check that they are fitted correctly and secured)
- Gas tubes and their switching equipment (solenoid valve)
- Gas cylinder securing elements
- Operating, message, safety and adjustment devices (Functional test)
- Other, general condition

6.2.2 Monthly maintenance tasks

- Casing damage (front, rear and side walls)
- Wheels and their securing elements
- Transport elements (strap, lifting lugs, handle)
- Selector switches, command devices, emergency stop devices, voltage reducing devices, message and control lamps
- Check coolant tubes and their connections for impurities
- Check that the wire guide elements (inlet nipple, wire guide tube) are fitted securely.

6.2.3 Annual test (inspection and testing during operation)

NOTE



The welding machine may only be tested by competent, capable persons!

A capable person is one who, because of his training, knowledge and experience, is able to recognise the dangers that can occur while testing welding power sources as well as possible subsequent damage and who is able to implement the required safety procedures.



For further information, please see the accompanying supplementary sheets "Machine and Company Data, Maintenance and Testing, Warranty"!

A periodic test according to IEC 60974-4 "Periodic inspection and test" has to be carried out. In addition to the regulations on testing given here, the relevant local laws and regulations must also be observed.

6.3 Maintenance work

DANGER



Do not carry out any unauthorised repairs or modifications!

To avoid injury and equipment damage, the unit must only be repaired or modified by specialist, skilled persons!

The warranty becomes null and void in the event of unauthorised interference.

- Appoint only skilled persons for repair work (trained service personnel)!

Repair and maintenance work may only be performed by qualified authorised personnel; otherwise the right to claim under warranty is void. In all service matters, always consult the dealer who supplied the machine. Return deliveries of defective equipment subject to warranty may only be made through your dealer. When replacing parts, use only original spare parts. When ordering spare parts, please quote the machine type, serial number and item number of the machine, as well as the type designation and item number of the spare part.

6.4 Disposing of equipment

NOTE



Proper disposal!

The machine contains valuable raw materials, which should be recycled, and electronic components, which must be disposed of.

- Do not dispose of in household waste!
- Observe the local regulations regarding disposal!



6.4.1 Manufacturer's declaration to the end user

- According to European provisions (guideline 2002/96/EG of the European Parliament and the Council of January, 27th 2003), used electric and electronic equipment may no longer be placed in unsorted municipal waste. It must be collected separately. The symbol depicting a waste container on wheels indicates that the equipment must be collected separately. This machine is to be placed for disposal or recycling in the waste separation systems provided for this purpose.
- According to German law (law governing the distribution, taking back and environmentally correct disposal of electric and electronic equipment (ElektroG) from 16.03.2005), used machines are to be placed in a collection system separate from unsorted municipal waste. The public waste management utilities (communities) have created collection points at which used equipment from private households can be disposed of free of charge.
- Information about giving back used equipment or about collections can be obtained from the respective municipal administration office.
- EWM participates in an approved waste disposal and recycling system and is registered in the Used Electrical Equipment Register (EAR) under number WEEE DE 57686922.
- In addition to this, returns are also possible throughout Europe via EWM sales partners.

6.5 Meeting the requirements of RoHS

We, EWM HIGHTEC Welding GmbH Mündersbach, hereby confirm that all products supplied by us which are affected by the RoHS Directive, meet the requirements of the RoHS (Directive 2002/95/EC).

7 Rectifying faults

All products are subject to rigorous production checks and final checks. If, despite this, something fails to work at any time, please check the product using the following flowchart. If none of the fault rectification procedures described leads to the correct functioning of the product, please inform your authorised dealer.

7.1 Customer checklist

Legend

↘: Fault/Cause

✘: Remedy

NOTE



The correct machine equipment for the material and process gas in use is a fundamental requirement for perfect operation!

Wire feed problems

- ↘ Contact tip blocked
 - ✘ Clean, spray with anti-spatter spray and replace if necessary
- ↘ Setting the spool brake (see "Setting the spool brake" chapter)
 - ✘ Check settings and correct if necessary
- ↘ Setting pressure units (see "Inching wire electrodes" chapter)
 - ✘ Check settings and correct if necessary
- ↘ Worn wire rolls
 - ✘ Check and replace if necessary
- ↘ Wire feed motor without supply voltage (automatic cutout triggered by overloading)
 - ✘ Reset triggered fuse (rear of the power source) by pressing the key button
- ↘ Kinked hose packages
 - ✘ Extend and lay out the torch hose package
- ↘ Wire guide core or spiral is dirty or worn
 - ✘ Clean core or spiral; replace kinked or worn cores

Functional errors

- ↘ Machine control without displaying the signal lights after switching on
 - ✘ Phase failure > check mains connection (fuses)
- ↘ No welding performance
 - ✘ Phase failure > check mains connection (fuses)
- ↘ Various parameters cannot be set
 - ✘ Entry level is blocked, disable access lock (see chapter entitled "Lock welding parameters against unauthorised access")
- ↘ Connection problems
 - ✘ Make control lead connections and check that they are fitted correctly.
- ↘ Loose welding current connections
 - ✘ Tighten power connections on the torch and/or on the workpiece
 - ✘ Tighten contact tip/collet correctly

8 Technical data

8.1 Mira 151, 221 MV, 251, 301

NOTE

 Performance specifications and guarantee only in connection with original spare and replacement parts!

Mira	151	221 MV	251	301
Switching steps	6		8	12
Welding current setting range	30 A–150 A	30 A–220 A	30 A–250 A	30 A–300 A
Duty cycle at 25 °C				
25%	150 A	220 A*	-	-
35%	-	-	250 A	300 A
100%	70 A	105 A*	150 A	170 A
Duty cycle at 40 °C				
15%	150 A	220 A*		
20%			250 A	300 A
100%	55 A	85 A*	125 A	150 A
Open circuit voltage	19,8 V–35.5 V	14.3 V–38.5 V	17.6 V–32.4 V	15.4 V–38.2 V
Mains connection lead	H07RN-F4G2,5	H07RN-F5G2,5	H07RN-F4G2,5	
Mains voltage (tolerance +/-15%)	1 x 230 V	1 x 230 V or 2 x 400 V	3 x 400 V	3 x 400 V
Frequency	50/60Hz			
Mains fuse (safety fuse, slow-blow)	1 x 16 A	1 x 16 A or 2 x 16 A	3 x 16 A	
Max. connected power	4,7 kVA	8 kVA	9.6 kVA	12.8 kVA
Recommended generator power	6,4 kVA	10,9 kVA	13 kVA	18 kVA
Cosφ	0.95			
Machine/torch cooling	Fan/gas			
Insulation class/protection classification	H/IP 23			
Ambient temperature	-20 °C to +40 °C			
WF speed	1.5-15m/min	1.5-20m/min		
Standard WF rollers	0.8+1.0mm (steel wire)			
Drive	2 rollers (37mm)		4 rollers (37mm)	
Torch connection	Eurocentral			
Workpiece lead	25mm ²	35mm ²		
Dimensions L/W/H [mm]	880x385x610			
Weight	47kg	56kg	60kg	72kg
EMC class	A			
Constructed to standards	IEC 60974-1, -5,-10 ☐ / ☐ / ☐			

* With 2x400V connection

9 Accessories

9.1 General accessories

Type	Designation	Item no.
ADAP DZA/EZA	Adapter for welding torches with Dinse connector to Euro central connector, on the machine	094-016765-00000
AK300	Adapter for K300 basket coil	094-001803-00001
DM1 32L/MIN	Manometer pressure regulator	094-000009-00000
GH 2X1/4" 2M	Gas hose	094-000010-00001

10 Replaceable parts

CAUTION



Damage due to the use of non-genuine parts!

The manufacturer's warranty becomes void if non-genuine parts are used!

- Only use system components and options (power sources, welding torches, electrode holders, remote controls, spare parts and replacement parts, etc.) from our range of products!
- Only insert and lock accessory components into the relevant connection socket when the machine is switched off.

10.1 Wire feed rollers

10.1.1 2-roll drive

10.1.1.1 Wire feed roller for steel wires

Type	Designation	Item no.
FE 1DR2R 0.6+0.8	Drive rollers, 37mm, 2 rollers, steel	094-003217-00000
FE 1DR2R 0.8+1.0	Drive rollers, 37mm, 2 rollers, steel	094-003218-00000
FE 1DR2R 0.9+1.2	Drive rollers, 37mm, 2 rollers, steel	094-003221-00000
FE 1DR2R 1.0+1.2	Drive rollers, 37mm, 2 rollers, steel	094-003219-00000

10.1.1.2 Wire feed rollers for aluminium wires

Type	Designation	Item no.
0.8+1.0/U/AL-TWIN-RO/37MM	"Aluminium" roller drive	094-005428-00000
1.0+1.2/U/AL-TWIN-RO/37MM	Drive rollers, 37mm, 1.0+1.2/U/Alu	094-003231-00000

Verschleißteile 2 Rollen-Antrieb Ø = 37mm		Wear parts 2-Roller drive system Ø = 37mm	
Stahldraht (V-Nut) "Standard-Stahl", oben unverzahnt und glatt, Rollenbezeichnung: "1,0"		Steel wire (V-groove) "Standard-Steel", on the top ungeared and plane, description of rolls: "1,0"	
Antriebsrollen-Ø (b): Drive rolls-Ø (b): 0,6 + 0,8 0,8 + 1,0 (Standard) 0,9 + 1,2 1,0 + 1,2	Ersatzteil: Spare part: 094-003217-00000 094-003218-00000 094-003221-00000 094-003219-00000		
Aluminiumdraht (U-Nut) "Option Alu", oben unverzahnt und glatt, Rollenbezeichnung: "0,8A"		Aluminium wire (U-groove) "Option Alu", on the top ungeared and plane, description of rolls: "0,8A"	
Antriebsrollen-Ø (b): Drive rolls-Ø (b): 0,8 + 1,0 1,0 + 1,2	Ersatzteil: Spare part: 094-005428-00000 094-003231-00000		

Figure 10-1

10.1.2 4-roll drive

10.1.2.1 Wire feed roller for steel wires

Type	Designation	Item no.
FE 2DR4R 0,6+0,8	Drive rollers, 37 mm, steel	092-000839-00000
FE 2DR4R 0,8+1,0	Drive rollers, 37 mm, steel	092-000840-00000
FE 2DR4R 0,9+1,2	Drive rollers, 37 mm, steel	092-000841-00000
FE 2DR4R 1,0+1,2	Drive rollers, 37 mm, steel	092-000842-00000

10.1.2.2 Wire feed rollers for aluminium wires

Type	Designation	Item no.
AL 2ZR2R 0.8+1.0	Twin wire feed rollers, 37mm, 2 rollers, for aluminium	092-000873-00000
AL 2ZR2R 1.0+1.2	Twin wire feed rollers, 37mm, 2 rollers, for aluminium	092-000828-00000

D		GB	
Verschleißteile 4 Rollen-Antrieb Ø = 37mm		Wear parts 4-Roller drive system Ø = 37mm	
Stahldraht (V-Nut) "Standard-Stahl", oben unverzahnt und glatt, Rollenbezeichnung: "1,0"		Steel wire (V-groove) "Standard-Steel", on the top ungeared and plane, description of rolls: "1,0"	
Antriebsrollen-Ø (b): Drive rolls-Ø (b): 0,6 + 0,8 0,8 + 1,0 (Standard) 0,9 + 1,2 1,0 + 1,2	Ersatzset: Spare set: 092-000839-00000 092-000840-00000 092-000841-00000 092-000842-00000		
Aluminiumdraht (U-Nut) "Option Alu", oben unverzahnt und glatt, Rollenbezeichnung: "0,8A"		Aluminium wire (U-groove) "Option Alu", on the top ungeared and plane, description of rolls: "0,8A"	
Antriebsrollen-Ø (b): Drive rolls-Ø (b): 0,8 + 1,0 1,0 + 1,2	Ersatzset: Spare set: 092-000873-00000 092-000828-00000		

Figure 10-2

11 Appendix A

11.1 Overview of EWM branches

Headquarters

EWM HIGHTEC WELDING GmbH
Dr. Günter-Henle-Straße 8
56271 Mündersbach · Germany
Tel: +49 2680 181-0 · Fax: -244
www.ewm-group.com · info@ewm-group.com

Technology centre

EWM HIGHTEC WELDING GmbH
Forststr. 7-13
56271 Mündersbach · Germany
Tel: +49 2680 181-0 · Fax: -144
www.ewm-group.com · info@ewm-group.com

Production, Sales and Service

EWM HIGHTEC WELDING GmbH
Dr. Günter-Henle-Straße 8
56271 Mündersbach · Germany
Tel: +49 2680 181-0 · Fax: -244
www.ewm-group.com · info@ewm-group.com

EWM HIGHTEC WELDING (Kunshan) Ltd.
10 Yuanshan Road, Kunshan · New & High-tech Industry Development Zone
Kunshan · Jiangsu · 215300 · People's Republic of China
Tel: +86 512 57867-188 · Fax: -182
www.ewm-group.com/cn · info.cn@ewm-group.com

EWM HIGHTEC WELDING AUTOMATION GmbH
Boxbachweg 4
08606 Oelsnitz/V. · Germany
Tel: +49 37421 20-300 · Fax: -318
www.ewm-group.com/automation · automation@ewm-group.com

EWM HIGHTEC WELDING s.r.o.
Tr. 9. května 718 / 31
407 53 Jiříkov · Czech Republic
Tel: +420 412 358-551 · Fax: -504
www.ewm-group.com/cz · info.cz@ewm-group.com

Sales and Service Germany

EWM HIGHTEC WELDING GmbH
Lindenstraße 1a
38723 Seesen-Rhüden · Tel: +49 5384 90798-0 · Fax: -20
www.ewm-group.com/handel · nl-seesen@ewm-group.com

EWM Schweißtechnik-Handels-GmbH
Sachsstraße 28
50259 Pulheim · Tel: +49 2234 697-047 · Fax: -048
www.ewm-group.com/handel · nl-koeln@ewm-group.com

EWM HIGHTEC WELDING GmbH
In der Florinskaul 14-16
56218 Mülheim-Kärlich · Tel: +49 261 988898-0 · Fax: -20
www.ewm-group.com/handel · nl-muelheim@ewm-group.com

EWM Schweißtechnik-Handels-GmbH
Eiserfelder Straße 300
57080 Siegen · Tel: +49 271 3878103-0 · Fax: -9
www.ewm-group.com/handel · nl-siegen@ewm-group.com

EWM HIGHTEC WELDING GmbH
Vertriebs- und Technologiezentrum
Draisstraße 2a
69469 Weinheim · Tel: +49 6201 84557-0 · Fax: -20
www.ewm-group.com/handel · nl-weinheim@ewm-group.com

EWM Schweißtechnik Handels GmbH
Rittergasse 1
89143 Blaubeuren · Tel: +49 7344 9191-75 · Fax: -77
www.ewm-group.com/handel · nl-ulm@ewm-group.com

EWM Schweißtechnik Handels GmbH
Heinkelstraße 8
89231 Neu-Ulm · Tel: +49 731 7047939-0 · Fax: -15
www.ewm-group.com/handel · nl-ulm@ewm-group.com

EWM HIGHTEC WELDING AUTOMATION GmbH
Steinfeldstrasse 15
90425 Nürnberg · Tel: +49 911 3841-727 · Fax: -728
www.ewm-group.com/automation
automation-nl-nuernberg@ewm-group.com

Sales and Service International

EWM HIGHTEC WELDING GmbH
Fichtenweg 1
4810 Gmunden · Austria · Tel: +43 7612 778 02-0 · Fax: -20
www.ewm-group.com/at · info.at@ewm-group.com

EWM HIGHTEC WELDING UK Ltd.
Unit 2B Coopies Way · Coopies Lane Industrial Estate
Morpeth · Northumberland · NE61 6JN · Great Britain
Tel: +44 1670 505875 · Fax: -514305
www.ewm-group.com/uk · info.uk@ewm-group.com

EWM HIGHTEC WELDING (Kunshan) Ltd.
10 Yuanshan Road, Kunshan · New & High-tech Industry Development Zone
Kunshan · Jiangsu · 215300 · People's Republic of China
Tel: +86 512 57867-188 · Fax: -182
www.ewm-group.com/cn · info.cn@ewm-group.com

EWM HIGHTEC WELDING Sales s.r.o. / Prodejní a poradenské centrum
Tyršova 2106
256 01 Benešov u Prahy · Czech Republic
Tel: +420 317 729-517 · Fax: -712
www.ewm-group.com/cz · sales.cz@ewm-group.com

EWM HIGHTEC WELDING FZCO / Regional Office Middle East
LOB 21 G 16 · P.O. Box 262851
Jebel Ali Free Zone · Dubai, UAE · United Arab Emirates
Tel: +971 48870-322 · Fax: -323
www.ewm-group.com/me · info.me@ewm-group.com