



Wire feed units for automated applications

M drive 4 Rob 2 WE
M drive 4 Rob 2 WI

Observe additional system documents!

099-004999-EW501

12.12.2011

Register now!
For your benefit
Jetzt Registrieren
und Profitieren!

www.ewm-group.com



General instructions

CAUTION



Read the operating instructions!

The operating instructions provide an introduction to the safe use of the products.

- Read the operating instructions for all system components!
- Observe accident prevention regulations!
- Observe all local regulations!
- Confirm with a signature where appropriate.

NOTE



In the event of queries on installation, commissioning, operation or special conditions at the installation site, or on usage, please contact your sales partner or our customer service department on +49 2680 181-0.

A list of authorised sales partners can be found at www.ewm-group.com.

Liability relating to the operation of this equipment is restricted solely to the function of the equipment. No other form of liability, regardless of type, shall be accepted. This exclusion of liability shall be deemed accepted by the user on commissioning the equipment.

The manufacturer is unable to monitor whether or not these instructions or the conditions and methods are observed during installation, operation, usage and maintenance of the equipment.

An incorrectly performed installation can result in material damage and injure persons as a result. For this reason, we do not accept any responsibility or liability for losses, damages or costs arising from incorrect installation, improper operation or incorrect usage and maintenance or any actions connected to this in any way.

© EWM HIGHTEC WELDING GmbH · Dr. Günter-Henle-Str. 8 · D-56271 Mündersbach, Germany

The copyright to this document remains the property of the manufacturer.

Reprinting, including extracts, only permitted with written approval.

Subject to technical amendments.

1 Contents

| | | |
|----------|---|-----------|
| 1 | Contents | 3 |
| 2 | Safety instructions | 5 |
| 2.1 | Notes on the use of these operating instructions | 5 |
| 2.2 | Explanation of icons..... | 6 |
| 2.3 | General | 7 |
| 2.4 | Transport and installation | 11 |
| 2.5 | Ambient conditions..... | 12 |
| 2.5.1 | In operation..... | 12 |
| 2.5.2 | Transport and storage | 12 |
| 3 | Intended use | 13 |
| 3.1 | Applications..... | 13 |
| 3.1.1 | Automation | 13 |
| 3.1.2 | For operation only with the following equipment | 13 |
| 3.2 | Documents which also apply | 14 |
| 3.2.1 | Warranty | 14 |
| 3.2.2 | Declaration of Conformity..... | 14 |
| 3.2.3 | Welding in environments with increased electrical hazards..... | 14 |
| 3.2.4 | Service documents (spare parts and circuit diagrams)..... | 14 |
| 4 | Machine description – quick overview | 15 |
| 4.1 | M drive 4 Rob 2 WI, WE | 15 |
| 4.1.1 | Front view | 15 |
| 4.1.2 | Rear view..... | 16 |
| 4.2 | Operating elements..... | 17 |
| 5 | Design and function | 18 |
| 5.1 | Installation..... | 18 |
| 5.1.1 | Mounting without carrier plate | 19 |
| 5.1.2 | Mounting with carrier plate (option)..... | 19 |
| 5.1.3 | Strain relief option for third party intermediate hose package..... | 20 |
| 5.2 | Intermediate hose package | 22 |
| 5.3 | Welding torch | 24 |
| 5.4 | Shielding gas and compressed air supply | 26 |
| 5.4.1 | Connection | 26 |
| 5.4.1.1 | Shielding gas..... | 26 |
| 5.4.1.2 | Compressed air..... | 26 |
| 5.4.2 | Settings..... | 26 |
| 5.4.2.1 | Shielding gas..... | 26 |
| 5.4.2.2 | Compressed air..... | 26 |
| 5.5 | Inching the wire electrode..... | 27 |
| 5.6 | Interfaces for automation | 29 |
| 6 | Maintenance, care and disposal | 31 |
| 6.1 | General | 31 |
| 6.2 | Maintenance work, intervals | 31 |
| 6.2.1 | Daily maintenance tasks | 31 |
| 6.2.2 | Monthly maintenance tasks..... | 31 |
| 6.2.3 | Annual test (inspection and testing during operation)..... | 31 |
| 6.3 | Maintenance work..... | 32 |
| 6.4 | Disposing of equipment | 32 |
| 6.4.1 | Manufacturer's declaration to the end user | 32 |
| 6.5 | Meeting the requirements of RoHS | 32 |
| 7 | Rectifying faults | 33 |
| 7.1 | Customer checklist..... | 33 |

| | | |
|-----------|--|-----------|
| 8 | Technical data | 34 |
| 8.1 | M drive 4 Rob 2..... | 34 |
| 9 | Accessories | 35 |
| 9.1 | Options..... | 35 |
| 10 | Replaceable parts | 36 |
| 10.1 | Wire feed rollers..... | 36 |
| 10.1.1 | Wire feed rollers for aluminium wire | 36 |
| 10.1.2 | Wire feed rollers for cored wire..... | 36 |
| 11 | Circuit diagrams | 37 |
| 11.1 | M drive 4 Rob 2 WI, WE..... | 37 |
| 12 | Appendix A | 38 |
| 12.1 | Overview of EWM branches..... | 38 |

2 Safety instructions

2.1 Notes on the use of these operating instructions

DANGER

Working or operating procedures which must be closely observed to prevent imminent serious and even fatal injuries.

- Safety notes include the "DANGER" keyword in the heading with a general warning symbol.
- The hazard is also highlighted using a symbol on the edge of the page.

WARNING

Working or operating procedures which must be closely observed to prevent serious and even fatal injuries.

- Safety notes include the "WARNING" keyword in the heading with a general warning symbol.
- The hazard is also highlighted using a symbol in the page margin.

CAUTION

Working or operating procedures which must be closely observed to prevent possible minor personal injury.

- The safety information includes the "CAUTION" keyword in its heading with a general warning symbol.
- The risk is explained using a symbol on the edge of the page.

CAUTION

Working and operating procedures which must be followed precisely to avoid damaging or destroying the product.

- The safety information includes the "CAUTION" keyword in its heading without a general warning symbol.
- The hazard is explained using a symbol at the edge of the page.

NOTE













Special technical points which users must observe.

- Notes include the "NOTE" keyword in the heading without a general warning symbol.

Instructions and lists detailing step-by-step actions for given situations can be recognised via bullet points, e.g.:

- Insert the welding current lead socket into the relevant socket and lock.

2.2 Explanation of icons

| Symbol | Description |
|---|---|
|  | Press |
|  | Do not press |
|  | Turn |
|  | Switch |
|  | Switch off machine |
|  | Switch on machine |
|  | ENTER (enter the menu) |
|  | NAVIGATION (Navigating in the menu) |
|  | EXIT (Exit the menu) |
|  | Time display (example: wait 4s/press) |
|  | Interruption in the menu display (other setting options possible) |
|  | Tool not required/do not use |
|  | Tool required/use |

2.3 General

DANGER



Electromagnetic fields!

The power source may cause electrical or electromagnetic fields to be produced which could affect the correct functioning of electronic equipment such as IT or CNC devices, telecommunication lines, power cables, signal lines and pacemakers.

- Observe the maintenance instructions! (see Maintenance and Testing chapter)
- Unwind welding leads completely!
- Shield devices or equipment sensitive to radiation accordingly!
- The correct functioning of pacemakers may be affected (obtain advice from a doctor if necessary).



Do not carry out any unauthorised repairs or modifications!

To avoid injury and equipment damage, the unit must only be repaired or modified by specialist, skilled persons!

The warranty becomes null and void in the event of unauthorised interference.

- Appoint only skilled persons for repair work (trained service personnel)!



Electric shock!

Welding machines use high voltages which can result in potentially fatal electric shocks and burns on contact. Even low voltages can cause you to get a shock and lead to accidents.

- Do not touch any live parts in or on the machine!
- Connection cables and leads must be free of faults!
- Switching off alone is not sufficient!
- Place welding torch and stick electrode holder on an insulated surface!
- The unit should only be opened by specialist staff after the mains plug has been unplugged!
- Only wear dry protective clothing!
- Wait for 4 minutes until the capacitors have discharged!

WARNING



Validity of this document!

This document is only valid in combination with the operating instructions for the power source being used (welding machine)!

- Read the operating instructions, in particular the safety instructions for the power source (welding machine)!



Risk of accidents if these safety instructions are not observed!

Non-observance of these safety instructions is potentially fatal!

- Carefully read the safety information in this manual!
- Observe the accident prevention regulations in your country.
- Inform persons in the working area that they must observe the regulations!

WARNING



Risk of injury due to radiation or heat!
Arc radiation results in injury to skin and eyes.
Contact with hot workpieces and sparks results in burns.

- Use welding shield or welding helmet with the appropriate safety level (depending on the application)!
- Wear dry protective clothing (e.g. welding shield, gloves, etc.) according to the relevant regulations in the country in question!
- Protect persons not involved in the work against arc beams and the risk of glare using safety curtains!



Explosion risk!
Apparently harmless substances in closed containers may generate excessive pressure when heated.

- Move containers with inflammable or explosive liquids away from the working area!
- Never heat explosive liquids, dusts or gases by welding or cutting!



Smoke and gases!
Smoke and gases can lead to breathing difficulties and poisoning. In addition, solvent vapour (chlorinated hydrocarbon) may be converted into poisonous phosgene due to the ultraviolet radiation of the arc!

- Ensure that there is sufficient fresh air!
- Keep solvent vapour away from the arc beam field!
- Wear suitable breathing apparatus if appropriate!



Fire hazard!
Flames may arise as a result of the high temperatures, stray sparks, glowing-hot parts and hot slag produced during the welding process.
Stray welding currents can also result in flames forming!

- Check for fire hazards in the working area!
- Do not carry any easily flammable objects such as matches or lighters.
- Keep appropriate fire extinguishing equipment to hand in the working area!
- Thoroughly remove any residue of flammable substances from the workpiece before starting welding.
- Only continue work on welded workpieces once they have cooled down.
Do not allow to come into contact with flammable material!
- Connect welding leads correctly!

CAUTION



Noise exposure!
Noise exceeding 70 dBA can cause permanent hearing damage!

- Wear suitable ear protection!
- Persons located within the working area must wear suitable ear protection!

CAUTION**Obligations of the operator!****The respective national directives and laws must be observed for operation of the machine!**

- National implementation of the framework directive (89/391/EWG), as well as the associated individual directives.
- In particular, directive (89/655/EWG), on the minimum regulations for safety and health protection when staff members use equipment during work.
- The regulations regarding work safety and accident prevention for the respective country.
- Setting up and operating the machine according to IEC 60974-9.
- Check at regular intervals that users are working in a safety-conscious way.
- Regular checks of the machine according to IEC 60974-4.

**Damage due to the use of non-genuine parts!****The manufacturer's warranty becomes void if non-genuine parts are used!**

- Only use system components and options (power sources, welding torches, electrode holders, remote controls, spare parts and replacement parts, etc.) from our range of products!
- Only insert and lock accessory components into the relevant connection socket when the machine is switched off.

**Damage to the machine due to stray welding currents!****Stray welding currents can destroy protective earth conductors, damage equipment and electronic devices and cause overheating of components leading to fire.**

- Make sure all welding leads are securely connected and check regularly.
- Always ensure a proper and secure electrical connection to the workpiece!
- Set up, attach or suspend all conductive power source components like casing, transport vehicle and crane frames so they are insulated!
- Do not place any other electronic devices such as drillers or angle grinders, etc., on the power source, transport vehicle or crane frames unless they are insulated!
- Always put welding torches and electrode holders on an insulated surface when they are not in use!

**Mains connection****Requirements for connection to the public mains network**

High-performance machines can influence the mains quality by taking current from the mains network. For some types of machines, connection restrictions or requirements relating to the maximum possible line impedance or the necessary minimum supply capacity at the interface with the public network (Point of Common Coupling, PCC) can therefore apply. In this respect, attention is also drawn to the machines' technical data. In this case, it is the responsibility of the operator, where necessary in consultation with the mains network operator, to ensure that the machine can be connected.

CAUTION



EMC Machine Classification

In accordance with IEC 60974-10, welding machines are grouped in two electromagnetic compatibility classes (see technical data):

Class A machines are not intended for use in residential areas where the power supply comes from the low-voltage public mains network. When ensuring the electromagnetic compatibility of class A machines, difficulties can arise in these areas due to interference not only in the supply lines but also in the form of radiated interference.

Class B machines fulfil the EMC requirements in industrial as well as residential areas, including residential areas connected to the low-voltage public mains network.

Setting up and operating

When operating arc welding systems, in some cases, electro-magnetic interference can occur although all of the welding machines comply with the emission limits specified in the standard. The user is responsible for any interference caused by welding.

In order to **evaluate** any possible problems with electromagnetic compatibility in the surrounding area, the user must consider the following: (see also EN 60974-10 Appendix A)

- Mains, control, signal and telecommunication lines
- Radios and televisions
- Computers and other control systems
- Safety equipment
- The health of neighbouring persons, especially if they have a pacemaker or wear a hearing aid
- Calibration and measuring equipment
- The immunity to interference of other equipment in the surrounding area
- The time of day at which the welding work must be carried out

Recommendations for reducing interference emission

- Mains connection, e.g. additional mains filter or shielding with a metal tube
- Maintenance of the arc welding equipment
- Welding leads should be as short as possible and run closely together along the ground
- Potential equalization
- Earthing of the workpiece. In cases where it is not possible to earth the workpiece directly, it should be connected by means of suitable capacitors.
- Shielding from other equipment in the surrounding area or the entire welding system

2.4 Transport and installation

WARNING



Incorrect handling of shielding gas cylinders!

Incorrect handling of shielding gas cylinders can result in serious and even fatal injury.

- Observe the instructions from the gas manufacturer and in any relevant regulations concerning the use of compressed air!
- Place shielding gas cylinders in the holders provided for them and secure with fixing devices.
- Avoid heating the shielding gas cylinder!



Risk of accident due to improper transport of machines that may not be lifted!

Do not lift or suspend the machine! The machine can fall down and cause injuries! The handles and brackets are suitable for transport by hand only!

- The machine may not be lifted by crane or suspended!

CAUTION



Risk of tipping!

There is a risk of the machine tipping over and injuring persons or being damaged itself during movement and set up. Tilt resistance is guaranteed up to an angle of 10° (according to IEC 60974-1, -3, -10).

- Set up and transport the machine on level, solid ground.
- Secure add-on parts using suitable equipment.



Damage due to supply lines not being disconnected!

During transport, supply lines which have not been disconnected (mains supply leads, control leads, etc.) may cause hazards such as connected equipment tipping over and injuring persons!

- Disconnect supply lines!

CAUTION



Equipment damage when not operated in an upright position!

The units are designed for operation in an upright position!

Operation in non-permissible positions can cause equipment damage.

- Only transport and operate in an upright position!

2.5 Ambient conditions

CAUTION



Installation site!

The machine must not be operated in the open air and must only be set up and operated on a suitable, stable and level base!

- The operator must ensure that the ground is non-slip and level, and provide sufficient lighting for the place of work.
- Safe operation of the machine must be guaranteed at all times.

CAUTION



Equipment damage due to dirt accumulation!

Unusually high quantities of dust, acid, corrosive gases or substances may damage the equipment.

- Avoid high volumes of smoke, vapour, oil vapour and grinding dust!
- Avoid ambient air containing salt (sea air)!



Non-permissible ambient conditions!

Insufficient ventilation results in a reduction in performance and equipment damage.

- Observe the ambient conditions!
- Keep the cooling air inlet and outlet clear!
- Observe the minimum distance of 0.5 m from obstacles!

2.5.1 In operation

Temperature range of the ambient air:

- -20 °C to +40 °C

Relative air humidity:

- Up to 50% at 40 °C
- Up to 90% at 20 °C

2.5.2 Transport and storage

Storage in an enclosed space, temperature range of the ambient air:

- -25 °C to +55 °C

Relative air humidity

- Up to 90% at 20 °C

3 Intended use

This machine has been manufactured according to the latest developments in technology and current regulations and standards. It must only be operated in line with the instructions on correct usage.

WARNING



Hazards due to improper usage!

Hazards may arise for persons, animals and material objects if the equipment is not used correctly. No liability is accepted for any damages arising from improper usage!

- The equipment must only be used in line with proper usage and by trained or expert staff!
- Do not modify or convert the equipment improperly!

CAUTION



Damage due to the use of non-genuine parts!

The manufacturer's warranty becomes void if non-genuine parts are used!

- Only use system components and options (power sources, welding torches, electrode holders, remote controls, spare parts and replacement parts, etc.) from our range of products!
- Only insert and lock accessory components into the relevant connection socket when the machine is switched off.

3.1 Applications

3.1.1 Automation

Automated, robot-controlled welding production with the digital robot power sources.

- Phoenix
- alpha Q

3.1.2 For operation only with the following equipment

Welding machine

- Phoenix 352, 452, 552 puls
- Phoenix 352, 452, 552, 1002 RC puls
- Phoenix 552 RC puls Tandem
- alpha Q 352, 552 RC
- alpha Q 352, 552

3.2 Documents which also apply

3.2.1 Warranty

NOTE



For further information, please see the accompanying supplementary sheets "Machine and Company Data, Maintenance and Testing, Warranty"!

3.2.2 Declaration of Conformity



The designated machine conforms to EC Directives and standards in terms of its design and construction:

- EC Low Voltage Directive (2006/95/EC),
- EC EMC Directive (2004/108/EC),

This declaration shall become null and void in the event of unauthorised modifications, improperly conducted repairs, non-observance of the deadlines for the repetition test and / or non-permitted conversion work not specifically authorised by the manufacturer.

The original copy of the declaration of conformity is enclosed with the unit.

3.2.3 Welding in environments with increased electrical hazards



In compliance with IEC / DIN EN 60974, VDE 0544 the machines can be used in environments with an increased electrical hazard.

3.2.4 Service documents (spare parts and circuit diagrams)



DANGER



Do not carry out any unauthorised repairs or modifications!

To avoid injury and equipment damage, the unit must only be repaired or modified by specialist, skilled persons!

The warranty becomes null and void in the event of unauthorised interference.

- Appoint only skilled persons for repair work (trained service personnel)!

Original copies of the circuit diagrams are enclosed with the unit.

Spare parts can be obtained from the relevant authorised dealer.

4 Machine description – quick overview

4.1 M drive 4 Rob 2 WI, WE

4.1.1 Front view

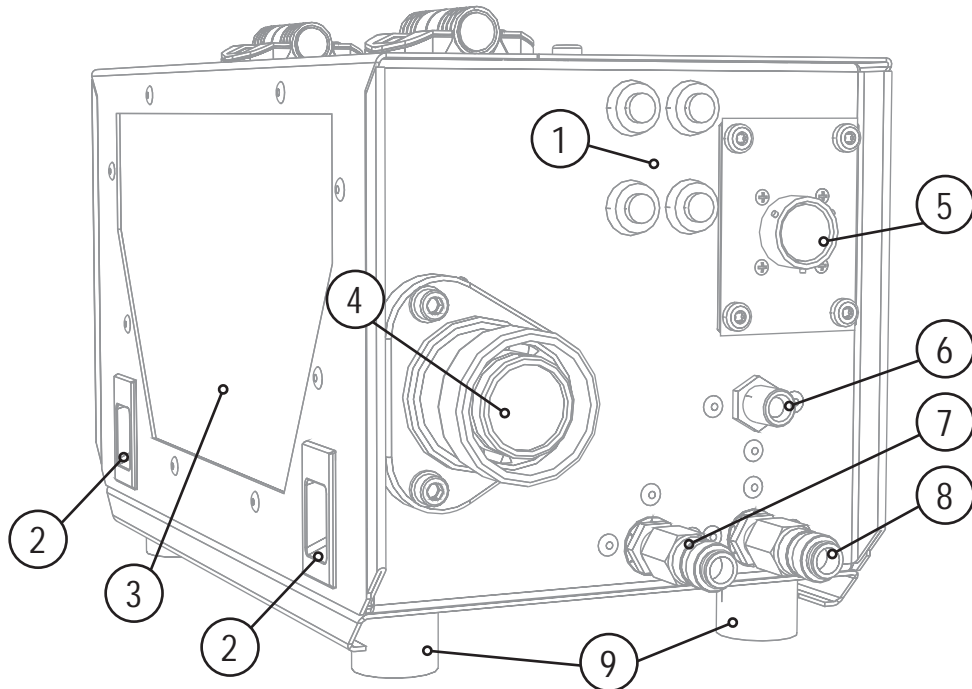

Figure 4-1

| Item | Symbol | Description |
|------|------------|--|
| 1 | | Machine control See Machine control – operating elements chapter |
| 2 | | Slide latch for opening the wire feed |
| 3 | | Wire feed unit |
| 4 | | Torch connection (Euro or Dinse central) Integrated with welding current and shielding gas |
| 5 | | 19-pole connection socket (analogue) Connection socket for analogue control signals (collision protection, etc.) |
| 6 | AIR | G 1/4" connecting nipple Compressed air for torch nozzle cleaning |
| 7 | | Quick connect coupling (blue) coolant supply |
| 8 | | Quick connect coupling (red) coolant return |
| 9 | | Machine feet |

4.1.2 Rear view

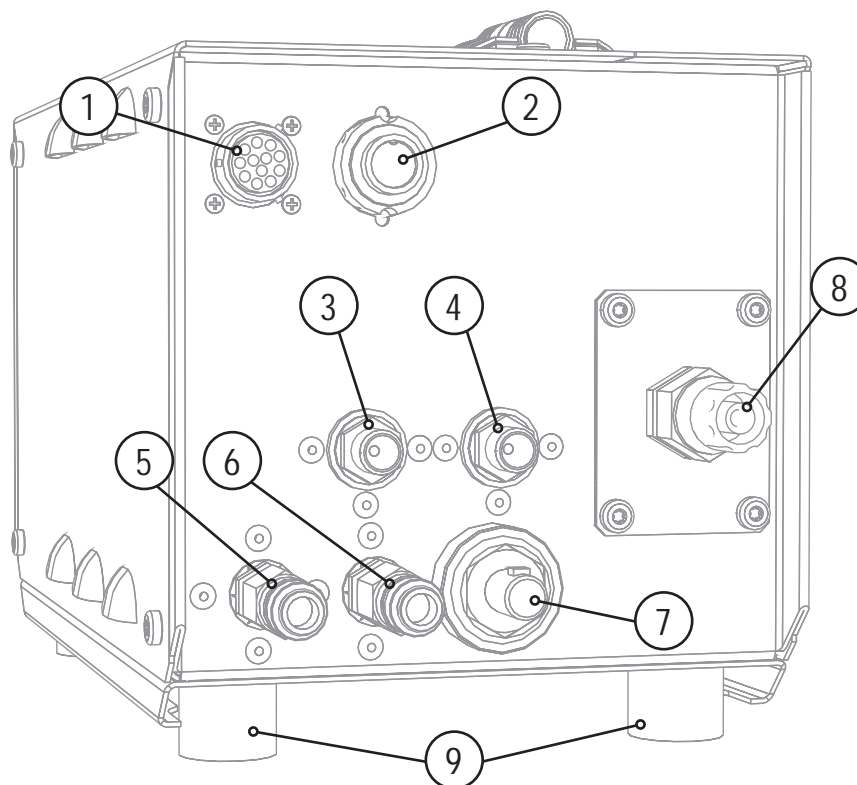

Figure 4-2

| Item | Symbol | Description |
|------|------------|--|
| 1 | | 12-pole connection socket (analogue) Connection socket for analogue control signals (collision protection, etc.) between the welding torch and the power source |
| 2 | | 7-pole connection socket (digital) Connection of control lead connection to power source |
| 3 | | Connecting nipple G$\frac{1}{4}$, shielding gas connection |
| 4 | AIR | G $\frac{1}{4}$" connecting nipple Compressed air for torch nozzle cleaning |
| 5 | | Quick connect coupling, red (coolant return) |
| 6 | | Quick connect coupling, blue (coolant supply) |
| 7 | | Connector plug, welding current "+" Welding current connection |
| 8 | | Wire inlet adapter plate Adapter plate for various wire inlets |
| 9 | | Machine feet |

4.2 Operating elements

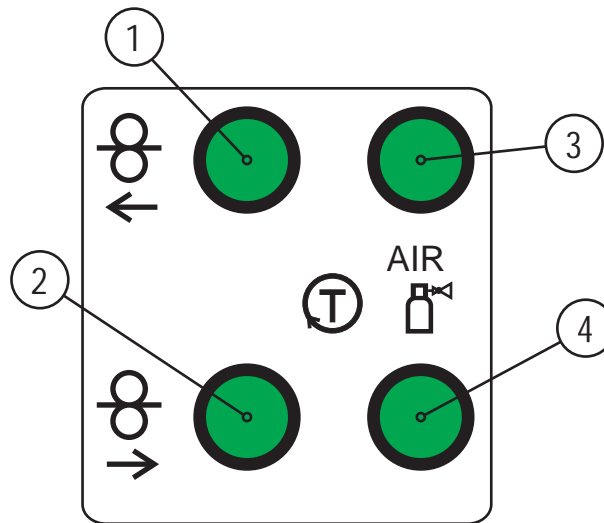

Figure 4-3

| Item | Symbol | Description |
|------|--------|---|
| 1 | | <p>"Wire inching" key button</p> <p>For inching the wire electrode when changing wire spools (wire inching begins with a speed of 1.0 m/min for 2 sec. It is subsequently increased to 6.0 m/min in 10 seconds with a ramp function.)</p> <p>The welding wire is inched into the tube package with the current off and without the gas being expelled.</p> |
| 2 | | <p>"Wire return" key button</p> <p>The welding wire is returned by the torch nozzle.</p> <p>The return speed increases the longer the button is pressed.</p> |
| 3 | | <p>"Blow-out" key button</p> <p>The torch nozzle is blown out in order to clean it.</p> |
| 4 | | <p>"Gas test" key button</p> <p>For checking and setting the gas flow quantity</p> |

5 Design and function

5.1 Installation



DANGER



Electric shock!

The casing on the wire feed unit robot must not have any electrically conductive connection to the protective conductor or to the robot (casing).

- Do not remove the rubber feet on the wire feed unit during assembly.



WARNING



Risk of accident due to improper transport of machines that may not be lifted!

Do not lift or suspend the machine! The machine can fall down and cause injuries! The handles and brackets are suitable for transport by hand only!

- The machine may not be lifted by crane or suspended!



CAUTION



Beware of electrical voltage!

The wire feed unit has to be fitted so that it is electrically insulated from wire feed and wire guide. If the unit is not fitted insulated electrically there is a risk of electric shock and/or damage to connected equipment.

- The large spool connector has to be installed in a material that does not conduct electricity (e.g. in the plastic hood of the wire feed unit).
- An insulation test as specified by the customary national laws and regulations has to be carried out on the unit.

5.1.1 Mounting without carrier plate

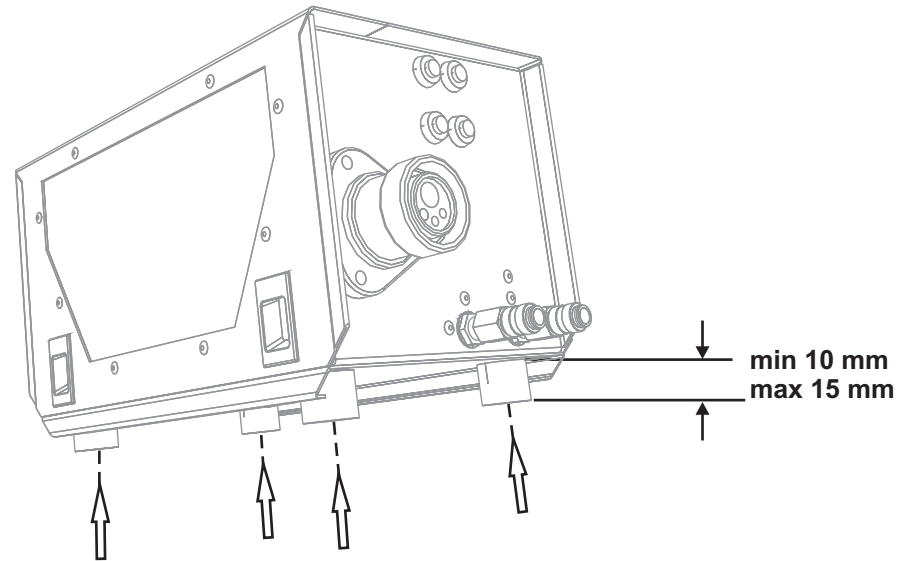

Figure 5-1

- The rubber feet have M8 internal threads.
- Screw in four screws with a length of between 10 and 15 mm!

5.1.2 Mounting with carrier plate (option)

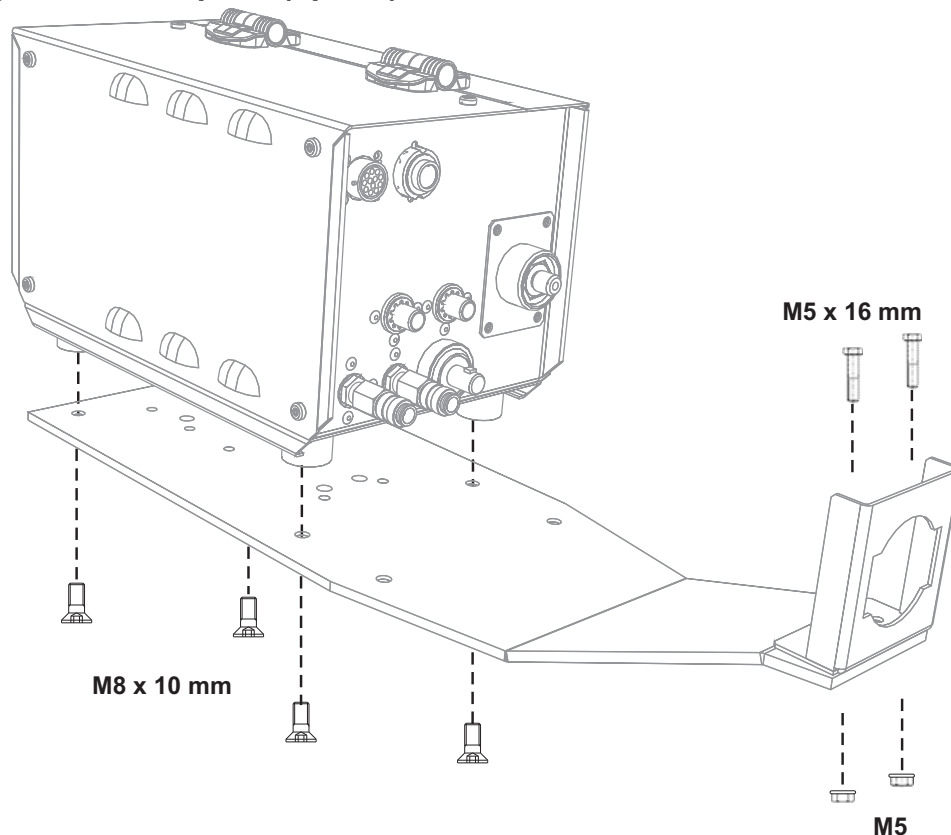

Figure 5-2

- Screw the carrier plate into the rubber feet using 4 x M8 countersunk head screws (supplied).
- Affix strain relief using 2 x M5 x 16 Threaded grooved pins (from above) and M5 ratchet nuts (from below) to the WF support.

5.1.3 Strain relief option for third party intermediate hose package

NOTE

The mounting plate with the standard strain relief is supplied from the factory as standard.

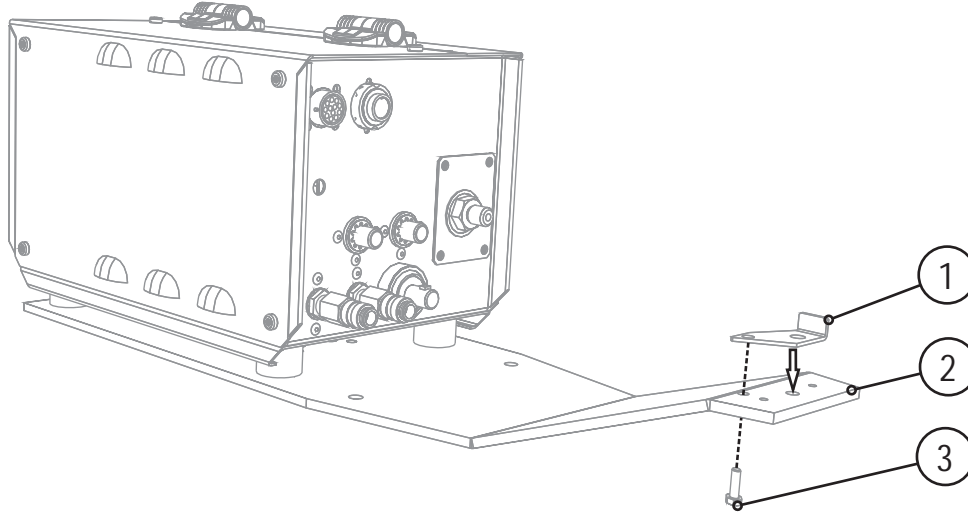

Figure 5-3

| Item | Symbol | Description |
|------|--------|-------------------|
| 1 | | Anti-twist device |
| 2 | | Carrier plate |
| 3 | | Screw, M4 x 16 mm |

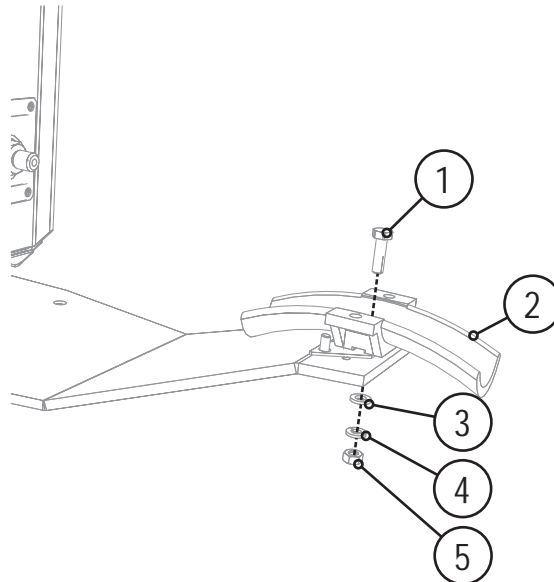

Figure 5-4

| Item | Symbol | Description |
|------|--------|----------------------------|
| 1 | | Hexagon screw, M6 x 20 mm |
| 2 | | Strain relief, bottom part |
| 3 | | Plain washer, M6 |
| 4 | | Spring ring, M6 |
| 5 | | Nut, M6 |

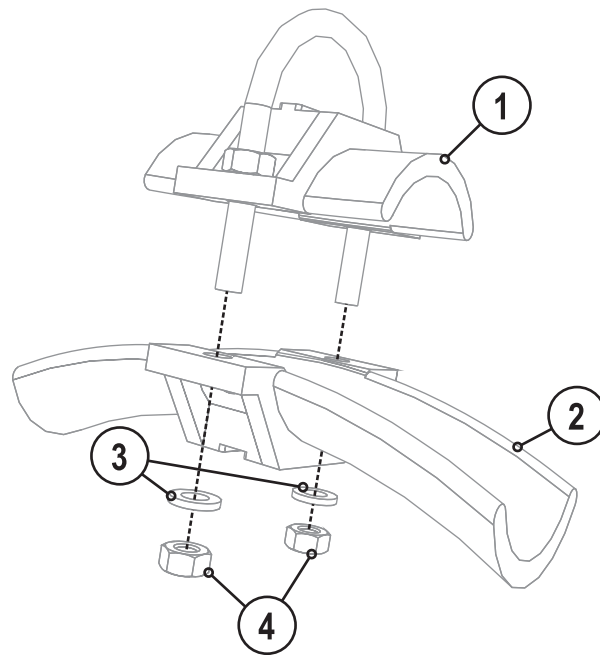

Figure 5-5

| Item | Symbol | Description |
|------|--------|---|
| 1 | | Strain relief, top part with fixing bracket |
| 2 | | Strain relief, bottom part |
| 3 | | Plain washer, M6 |
| 4 | | Nut, M6 |

5.2 Intermediate hose package

CAUTION



Risk of injury due to electrical current!

The earth cable on the intermediate tube package must not be connected to the welding machine or wire feed unit!

- Remove the earth cable or push it back into the tube package.

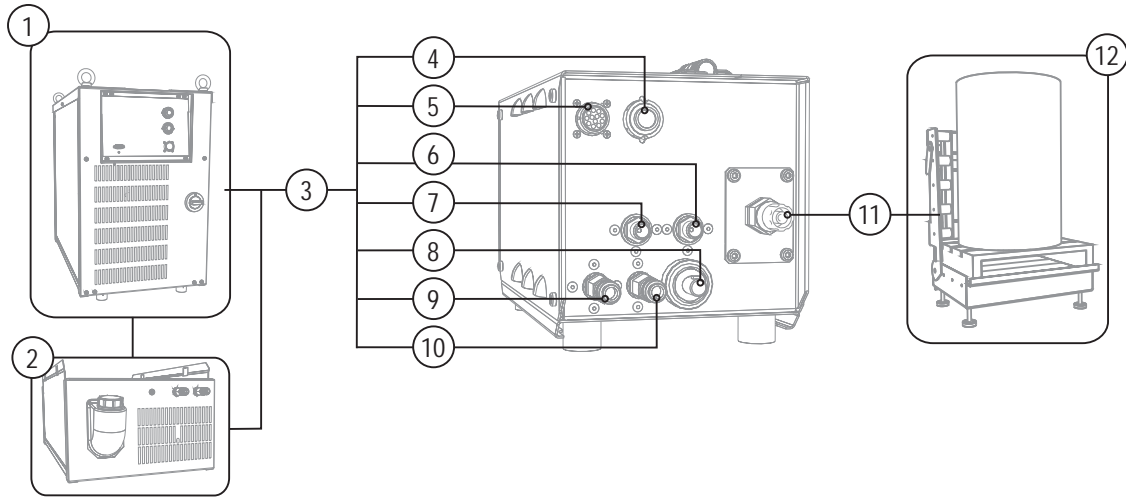









Figure 5-6

| Item | Symbol | Description |
|------|--|--|
| 1 | | Power source |
| 2 |  | Cooling module |
| 3 | | Intermediate hose package |
| 4 |  | 7-pole connection socket (digital) Connection of control lead connection to power source |
| 5 |  | 12-pole connection socket (analogue) Connection socket for analogue control signals (collision protection, etc.) between the welding torch and the power source |
| 6 | AIR | G 1/4" connecting nipple Compressed air for torch nozzle cleaning |
| 7 |  | Connecting nipple G1/4, shielding gas connection |
| 8 |  | Connector plug, welding current "+" Welding current connection |
| 9 |  | Quick connect coupling, red (coolant return) |
| 10 |  | Quick connect coupling, blue (coolant supply) |
| 11 | | Wire feed nipple (wire feed from external source) |
| 12 | | External welding wire source |

- Insert the end of the tube package through the strain relief of the tube package and lock by turning to the right.
- Insert the plug on the welding current lead into the "+" welding current connection socket and lock.
- Lock the connecting nipples on the cooling water tubes into place in the appropriate rapid-action closure couplings: Connect the red return line to red rapid-action closure coupling (coolant return) and the blue supply line to the blue rapid-action closure coupling (coolant supply).
- Insert the plug of the control cable into the 7-pole connection socket (digital) and secure with the crown nut (the plug can only be inserted in one position into the connection socket).
- Connect the crown nut on the shielding gas lead to the G1/4" connecting nipple, connect the shielding gas.
- Connect the crown nut on the compressed air line to the G1/4" connecting nipple, connect the compressed air connection.
- Insert the plug of the control cable into the 12-pole connection socket (analogue) and secure with the crown nut (the plug only permits one position).

NOTE



A pilot static tube for a gas flow of 0-16 l/min is fitted on each wire feed unit as standard. For applications where a higher gas flow rate is required (e.g. for aluminium), a pilot static tube of 0-25 l/min (see accessories) should be installed.

5.3 Welding torch

CAUTION



Equipment damage due to improperly connected coolant lines!

If the coolant lines are not connected or a gas-cooled welding torch is used, the coolant circuit is interrupted and equipment damage can occur.

- Connect all coolant lines correctly!
- When using a gas-cooled welding torch, add a tube bridge to the coolant circuit (see chapter "Accessories").

NOTE



Fault with the wire guide!

On delivery, the central connector (Euro) is fitted with a capillary tube for welding torches with spiral guides. Conversion is necessary if a welding torch with a plastic core is used!

Welding torch with plastic core:

- use with guide tube!

Welding torch with spiral guide:

- use with capillary tube!

Depending on the wire electrode diameter or type, either a spiral guide or plastic core with the correct inner diameter has to be inserted in the torch!

Recommendation:

- Use a spiral guide to weld hard, unalloyed wire electrodes (steel).
- Use a plastic core to weld or braze soft, high-alloy wire electrodes or aluminium materials.

Preparation for connecting welding torches with a plastic core:

- Push forward the capillary tube on the wire feed side in the direction of the central connector and remove it there.
- Slide plastic core guide tube off the central connector.
- Carefully insert the central plug for the welding torch, with the still oversized plastic liner, into the central connector and screw together with crown nut.
- Use a suitable tool to cut off the plastic liner just before the wire feed roller, making sure not to pinch it.
- Unfasten and remove the central plug on the welding torch.
- Cleanly remove the burr from the separated end of the plastic core!

Preparation for connecting welding torches with a spiral guide:

- Check that the capillary tube is correctly positioned in relation to the central connector!

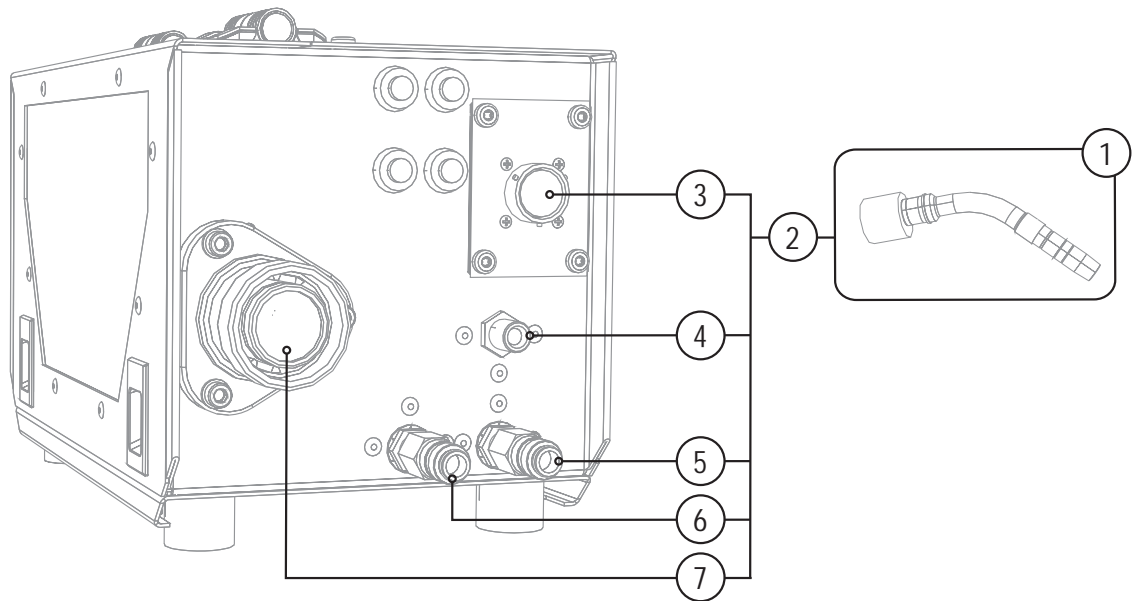

Figure 5-7

| Item | Symbol | Description |
|------|------------|--|
| 1 | | Welding torch |
| 2 | | Welding torch hose package |
| 3 | | 19-pole connection socket (analogue) Connection socket for analogue control signals (collision protection, etc.) |
| 4 | AIR | G 1/4" connecting nipple Compressed air for torch nozzle cleaning |
| 5 | | Quick connect coupling (red) coolant return |
| 6 | | Quick connect coupling (blue) coolant supply |
| 7 | | Torch connection (Euro or Dinse central) Integrated with welding current and shielding gas |

- Insert the end of the tube package through the strain relief (either on the WF support or customer-specific attachment). After attaching all the connections, tighten the screws on the strain relief.
- Insert the central plug for the welding torch into the central connector and screw together with crown nut.
- Lock the connecting nipples on the cooling water tubes into place in the appropriate rapid-action closure couplings:
Connect the red return line to red rapid-action closure coupling (coolant return) and the blue supply line to the blue rapid-action closure coupling (coolant supply).
- Insert the torch control lead plus into the 19-pole connection socket and lock.
- Screw the compressed air connection from the torch onto the "AIR" connecting nipple. (Only torches supporting compressed air cleaning)

NOTE



The compressed air connection must always be established with torches cleaned using compressed air!

5.4 Shielding gas and compressed air supply

5.4.1 Connection

WARNING



Incorrect handling of shielding gas cylinders!

Incorrect handling of shielding gas cylinders can result in serious and even fatal injury.

- Observe the instructions from the gas manufacturer and in any relevant regulations concerning the use of compressed air!
- Place shielding gas cylinders in the holders provided for them and secure with fixing devices.
- Avoid heating the shielding gas cylinder!

NOTE



No impurities must be allowed to enter the shielding gas or compressed air supply, as these can cause blockages. Before connecting the pressure reducer to the gas cylinder, open the cylinder valve briefly to blow out any dirt. All connections must be gas tight.

5.4.1.1 Shielding gas

- Mount the pressure reducer onto the gas cylinder valve.
- Screw together gas tube (tube package of WF unit) on the gas cylinder pressure reducer, using G 1/4" connecting nipple.

5.4.1.2 Compressed air

- Screw the compressed air line onto the connecting nipple.
- Establish the compressed air connection between the welding torch and connecting nipple.

5.4.2 Settings

5.4.2.1 Shielding gas

NOTE



A pilot static tube for a gas flow of 0-16 l/min is fitted on each wire feed unit as standard. For applications where a higher gas flow rate is required (e.g. for aluminium), a pilot static tube of 0-25 l/min (see accessories) should be installed.

- Slowly open the gas cylinder valve.
- Open the pressure reducer.
- Switch on the power source.
- Press the Gas test button.
- Set shielding gas quantity on the pressure reducer depending on the precise application.

5.4.2.2 Compressed air

NOTE



The compressed air must be free of oil and water. Observe the information provided by the welding torch manufacturer.

- Press Blow Out key button to blast away impurities on the torch nozzle.

5.5 Inching the wire electrode

CAUTION**Risk of injury due to welding wire escaping from the welding torch!****The welding wire can escape from the welding torch at high speed and cause bodily injury including injuries to the face and eyes!**

- Never direct the welding torch towards your own body or towards other persons!

**Risk of injury due to moving parts!****The wire feed units are equipped with moving parts, which can trap hands, hair, clothing or tools and thus injure persons!**

- Do not reach into rotating or moving parts or drive components!
- Keep casing covers closed during operation!

CAUTION**Extensive wear due to incorrect contact pressure!****Incorrect contact pressure will cause extensive wear of the wire feed rollers!**

- With the adjusting nuts of the pressure units set the contact pressure so that the wire electrode is conveyed but will still slip through if the wire spool jams.
- Set the contact pressure of the front rollers (in wire feed direction) to a higher value!

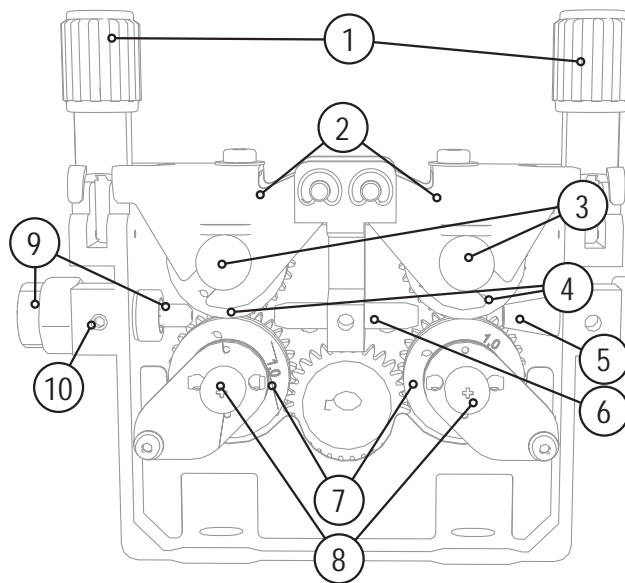

Figure 5-8

NOTE**Depending on the design of the machine, the design of the wire feed may be the reverse of that shown!**

| Item | Symbol | Description |
|------|--------|---------------------------------------|
| 1 | | Pressure units |
| 2 | | Clamping units |
| 3 | | Knurled nut |
| 4 | | Pressure rollers |
| 5 | | Wire holding nipple |
| 6 | | Guide tube |
| 7 | | Drive rollers |
| 8 | | "Undetachable" knurled screws |
| 9 | | Wire feed nipple with wire stabiliser |
| 10 | | "Wire inlet nipple" fixing screw |

- Extend and lay out the torch hose package.
- Unfasten pressure units and fold out (clamping units and pressure rollers will automatically flip upwards).
- Unwind welding wire carefully from the wire spool and insert through the wire inlet nipple over the drive roller grooves and the guide pipe into the capillary tube and Teflon core using guide pipe.
- Press the clamping element with the pressure roller back downwards and fold the wire units back up again (wire electrode should be in the groove on the drive roller).
- Set the contact pressure with the adjusting nuts of the pressure unit.
- Press the wire inching button until the wire electrode projects out of the welding torch.

NOTE



The inching speed is infinitely adjustable by simultaneously pressing the wire inching button and turning the wire speed rotary dial. The display shows the selected inching speed.

5.6 Interfaces for automation

CAUTION



Equipment damage due to unshielded control leads!
Unshielded control leads can cause damage to the power source and accessory components.

- Use shielded control leads only.

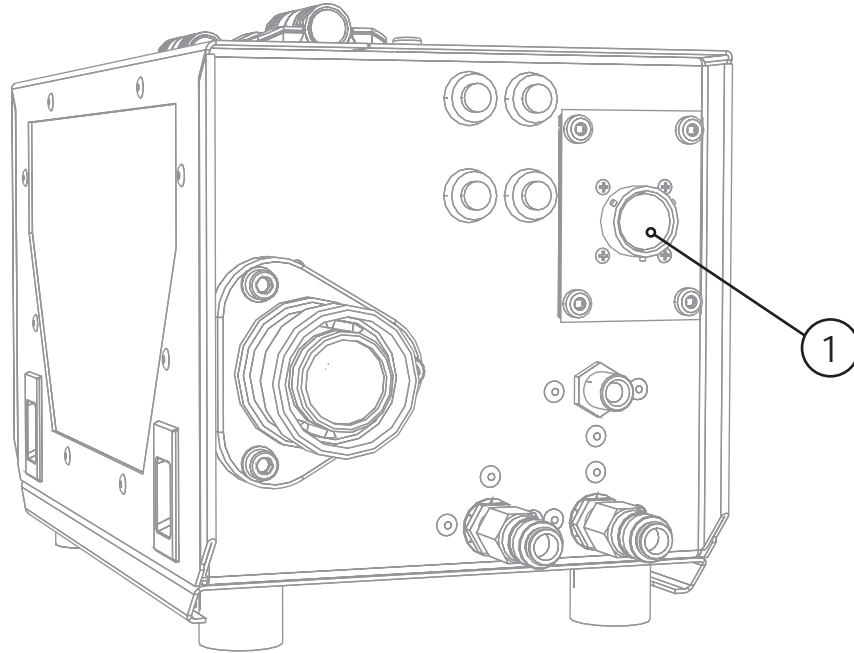



Figure 5-9

| Item | Symbol | Description |
|------|---|--|
| 1 |  | 19-pole connection socket (analogue) Connection socket for analogue control signals (collision protection, etc.) |

| Pin | Signal type | Name | Description |
|-----|-------------|---------------------------|---|
| A | Input | PE dyn. | Cable screen |
| B | Input | Emergency stop 1 | Collision protection |
| C | Input | Emergency stop 2 | Collision protection |
| D | Input | Emergency stop 3 | Collision protection |
| E | Input | Gas nozzle sensor 1 | Example, can be freely assigned |
| F | Input | Gas nozzle sensor 2 | Example, can be freely assigned |
| G | Input | Currentless WF 1 | Example, can be freely assigned |
| H | Input | Currentless WF 2 | Example, can be freely assigned |
| J | Input | UDraht measurement sensor | Workpiece search with gas nozzle |
| K | Input | Contact sensor | Example, can be freely assigned |
| L | Output | 0VAC | |
| M | Input | Gas test | Gas test push-button (contact switch with pin L) |
| N | Input | Inching | Inching push-button (contact switch with pin P) |
| P | Output | 0 V1 | |
| R | | | Protection against a remote controller being plugged in unintentionally |
| S | | | |
| T | | | |
| U | Output | Motor- | Power supply for push/pull "-" |
| V | Output | Motor+ | Power supply for push/pull "+" |

NOTE



All connections described as "Example, can be freely assigned" can be modified to the customer's requirements. The suggestions in the table must be observed, however (keep connection diagrams with the machine documentation).

6 Maintenance, care and disposal



DANGER



Risk of injury from electric shock!

Cleaning machines that are not disconnected from the mains can lead to serious injuries!

- Disconnect the machine completely from the mains.
- Remove the mains plug!
- Wait for 4 minutes until the capacitors have discharged!

6.1 General

When used in the specified environmental conditions and under normal operating conditions, this machine is largely maintenance-free and requires a minimum of care.

There are some points, which should be observed, to guarantee fault-free operation of your welding machine. Among these are regular cleaning and checking as described below, depending on the pollution level of the environment and the length of time the unit is in use.

6.2 Maintenance work, intervals

6.2.1 Daily maintenance tasks

- Check correct mounting of the wire spool.
- Mains supply lead and its strain relief
- Welding current cables (check that they are fitted correctly and secured)
- Gas tubes and their switching equipment (solenoid valve)
- Gas cylinder securing elements
- Operating, message, safety and adjustment devices (Functional test)
- Other, general condition

6.2.2 Monthly maintenance tasks

- Casing damage (front, rear and side walls)
- Wheels and their securing elements
- Transport elements (strap, lifting lugs, handle)
- Selector switches, command devices, emergency stop devices, voltage reducing devices, message and control lamps
- Check coolant tubes and their connections for impurities
- Check that the wire guide elements (inlet nipple, wire guide tube) are fitted securely.

6.2.3 Annual test (inspection and testing during operation)

NOTE



The welding machine may only be tested by competent, capable persons!

A capable person is one who, because of his training, knowledge and experience, is able to recognise the dangers that can occur while testing welding power sources as well as possible subsequent damage and who is able to implement the required safety procedures.



For further information, please see the accompanying supplementary sheets "Machine and Company Data, Maintenance and Testing, Warranty"!

A periodic test according to IEC 60974-4 "Periodic inspection and test" has to be carried out. In addition to the regulations on testing given here, the relevant local laws and regulations must also be observed.

6.3 Maintenance work

DANGER



- Do not carry out any unauthorised repairs or modifications!**
To avoid injury and equipment damage, the unit must only be repaired or modified by specialist, skilled persons!
The warranty becomes null and void in the event of unauthorised interference.
- Appoint only skilled persons for repair work (trained service personnel)!

Repair and maintenance work may only be performed by qualified authorised personnel; otherwise the right to claim under warranty is void. In all service matters, always consult the dealer who supplied the machine. Return deliveries of defective equipment subject to warranty may only be made through your dealer. When replacing parts, use only original spare parts. When ordering spare parts, please quote the machine type, serial number and item number of the machine, as well as the type designation and item number of the spare part.

6.4 Disposing of equipment

NOTE



- Proper disposal!**
The machine contains valuable raw materials, which should be recycled, and electronic components, which must be disposed of.
- Do not dispose of in household waste!
 - Observe the local regulations regarding disposal!



6.4.1 Manufacturer's declaration to the end user

- According to European provisions (guideline 2002/96/EG of the European Parliament and the Council of January, 27th 2003), used electric and electronic equipment may no longer be placed in unsorted municipal waste. It must be collected separately. The symbol depicting a waste container on wheels indicates that the equipment must be collected separately.
This machine is to be placed for disposal or recycling in the waste separation systems provided for this purpose.
- According to German law (law governing the distribution, taking back and environmentally correct disposal of electric and electronic equipment (ElektroG) from 16.03.2005), used machines are to be placed in a collection system separate from unsorted municipal waste. The public waste management utilities (communities) have created collection points at which used equipment from private households can be disposed of free of charge.
- Information about giving back used equipment or about collections can be obtained from the respective municipal administration office.
- EWM participates in an approved waste disposal and recycling system and is registered in the Used Electrical Equipment Register (EAR) under number WEEE DE 57686922.
- In addition to this, returns are also possible throughout Europe via EWM sales partners.

6.5 Meeting the requirements of RoHS

We, EWM HIGHTEC Welding GmbH Mündersbach, hereby confirm that all products supplied by us which are affected by the RoHS Directive, meet the requirements of the RoHS (Directive 2002/95/EC).

7 Rectifying faults

All products are subject to rigorous production checks and final checks. If, despite this, something fails to work at any time, please check the product using the following flowchart. If none of the fault rectification procedures described leads to the correct functioning of the product, please inform your authorised dealer.

7.1 Customer checklist

| Legend | Symbol | Description |
|--------|--------|-------------|
| | ↯ | Fault/Cause |
| | ✘ | Remedy |

NOTE



The correct machine equipment for the material and process gas in use is a fundamental requirement for perfect operation!

Wire feed problems

- ↯ Contact tip blocked
 - ✘ Clean, spray with anti-spatter spray and replace if necessary
- ↯ Setting the spool brake (see "Setting the spool brake" chapter)
 - ✘ Check settings and correct if necessary
- ↯ Setting pressure units (see "Inching wire electrodes" chapter)
 - ✘ Check settings and correct if necessary
- ↯ Worn wire rolls
 - ✘ Check and replace if necessary
- ↯ Wire feed motor without supply voltage (automatic cutout triggered by overloading)
 - ✘ Reset triggered fuse (rear of the power source) by pressing the key button
- ↯ Kinked hose packages
 - ✘ Extend and lay out the torch hose package
- ↯ Wire guide core or spiral is dirty or worn
 - ✘ Clean core or spiral; replace kinked or worn cores

Functional errors

- ↯ Machine control without displaying the signal lights after switching on
 - ✘ Phase failure > check mains connection (fuses)
- ↯ No welding performance
 - ✘ Phase failure > check mains connection (fuses)
- ↯ Various parameters cannot be set
 - ✘ Entry level is blocked, disable access lock (see chapter entitled "Lock welding parameters against unauthorised access")
- ↯ Connection problems
 - ✘ Make control lead connections and check that they are fitted correctly.
- ↯ Loose welding current connections
 - ✘ Tighten power connections on the torch and/or on the workpiece
 - ✘ Tighten contact tip correctly

8 Technical data

8.1 M drive 4 Rob 2

NOTE

Performance specifications and guarantee only in connection with original spare and replacement parts!

| | |
|---|---|
| Supply voltage | 42 VAC |
| max. welding current at 60% DC | 550 A |
| Wire feed speed | 0.5 m/min to 24 m/min |
| Wire feed speed steps | 0.1 m/min |
| Standard WF roller equipment | 1.0 + 1.2 mm (for steel wire) |
| Ambient temperature | -20 °C to +40 °C |
| Torch connection | Euro torch connector Dinse connector |
| Drive | 4-roller (37 mm) |
| Protection classification | IP 23 |
| Dimensions (L x W x H) in mm without assembly plate (Euro connector) with assembly plate (Euro connector) | 407 x 201 x 229 700 x 201 x 245 |
| Weight with assembly plate | 9.8 kg |
| EMC class | A |
| Constructed to standard | IEC 60974 -1, -5, -10 |

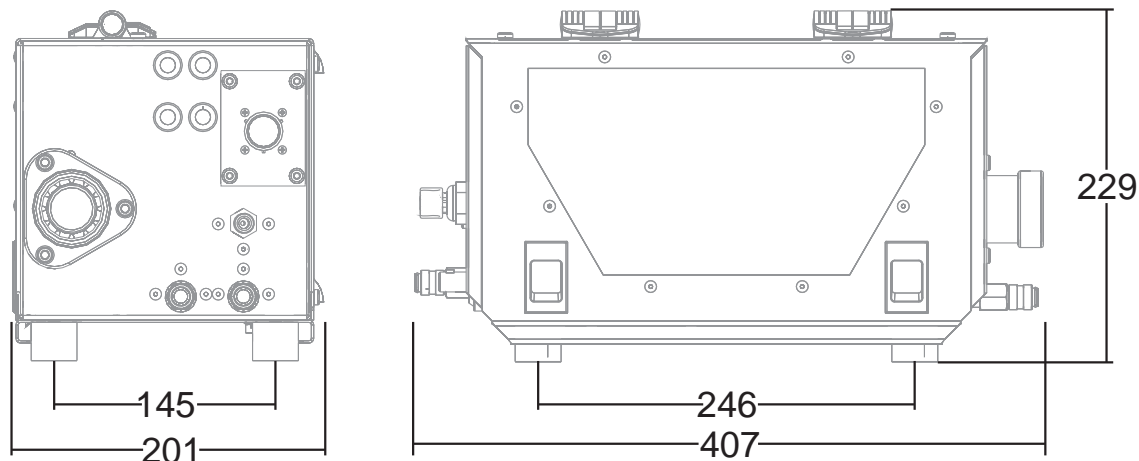

Figure 8-1

9 Accessories

NOTE



Performance-dependent accessories like torches, workpiece leads, electrode holders or intermediate hose packages are available from your authorised dealer.

9.1 Options

| Type | Designation | Item no. |
|---------------------|--|------------------|
| ON ZWIPA-CONNECTION | Retrofit option for third party INTPA strain relief | 094-007890-00000 |
| ON 14-POLE WF ROB | Retrofit option for 14-pole connection socket with cable harness | 092-001749-00000 |
| GS25L G1/4" SW 17 | Pilot static tube | 094-001100-00000 |

10 Replaceable parts

10.1 Wire feed rollers

CAUTION



Damage due to the use of non-genuine parts!

The manufacturer's warranty becomes void if non-genuine parts are used!

- Only use system components and options (power sources, welding torches, electrode holders, remote controls, spare parts and replacement parts, etc.) from our range of products!
- Only insert and lock accessory components into the relevant connection socket when the machine is switched off.

10.1.1 Wire feed rollers for aluminium wire

| Type | Designation | Item no. |
|-----------------------|--|------------------|
| URUE AL 4ZR4R 0,8+1,0 | Conversion kit, 37mm, 4-roller drive for aluminium | 092-000867-00000 |
| URUE AL 4ZR4R 1,0+1,2 | Conversion kit, 37mm, 4-roller drive for aluminium | 092-000846-00000 |
| URUE AL 4ZR4R 1,2+1,6 | Conversion kit, 37mm, 4-roller drive for aluminium | 092-000847-00000 |
| URUE AL 4ZR4R 2,4+3,2 | Conversion kit, 37mm, 4-roller drive for aluminium | 092-000868-00000 |

10.1.2 Wire feed rollers for cored wire

| Type | Designation | Item no. |
|-----------------------------------|---|------------------|
| URUE ROE 2DR4R 0,8/0,9+0,8/0,9 | Conversion kit, 37mm, 4-roller drive for cored wire | 092-000830-00000 |
| URUE ROE 2DR4R 1,0/1,2+1,4/1,6 | Conversion kit, 37mm, 4-roller drive for cored wire | 092-000831-00000 |
| URUE ROE 2DR4R 1,4/1,6+2,0/2,4 | Conversion kit, 37mm, 4-roller drive for cored wire | 092-000832-00000 |
| URUE ROE 2DR4R 2,8+3,2 | Conversion kit, 37mm, 4-roller drive for cored wire | 092-000833-00000 |
| URUE VERZ>UNVERZ FE/AL 4R | Conversion kit, 37mm, 4-roller drive on non-toothed rollers (steel/aluminium) | 092-000845-00000 |

11 Circuit diagrams

NOTE

👉 Original format circuit diagrams are located inside the machine.

11.1 M drive 4 Rob 2 WI, WE

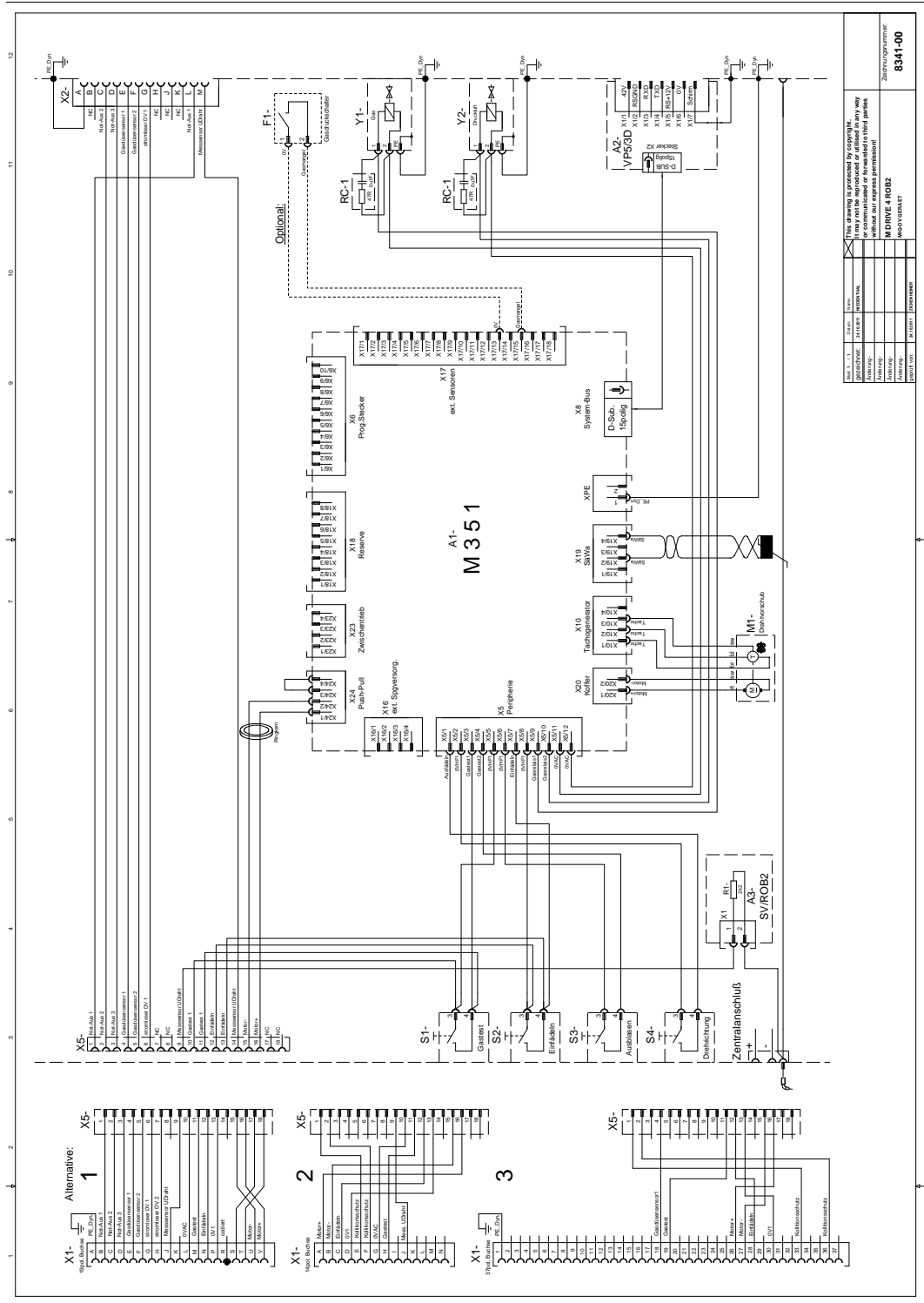

Figure 11-1

12 Appendix A

12.1 Overview of EWM branches

Headquarters

EWM HIGHTEC WELDING GmbH
Dr. Günter-Henle-Straße 8
56271 Mündersbach · Germany
Tel: +49 2680 181-0 · Fax: -244
www.ewm-group.com · info@ewm-group.com

Technology centre

EWM HIGHTEC WELDING GmbH
Forststr. 7-13
56271 Mündersbach · Germany
Tel: +49 2680 181-0 · Fax: -144
www.ewm-group.com · info@ewm-group.com

Production, Sales and Service

EWM HIGHTEC WELDING GmbH
Dr. Günter-Henle-Straße 8
56271 Mündersbach · Germany
Tel: +49 2680 181-0 · Fax: -244
www.ewm-group.com · info@ewm-group.com

EWM HIGHTEC WELDING (Kunshan) Ltd.
10 Yuanshan Road, Kunshan · New & High-tech Industry Development Zone
Kunshan · Jiangsu · 215300 · People's Republic of China
Tel: +86 512 57867-188 · Fax: -182
www.ewm-group.com/cn · info.cn@ewm-group.com

EWM HIGHTEC WELDING AUTOMATION GmbH
Boxbachweg 4
08606 Oelsnitz/V. · Germany
Tel: +49 37421 20-300 · Fax: -318
www.ewm-group.com/automation · automation@ewm-group.com

EWM HIGHTEC WELDING s.r.o.
Tr. 9. května 718 / 31
407 53 Jiřikov · Czech Republic
Tel: +420 412 358-551 · Fax: -504
www.ewm-group.com/cz · info.cz@ewm-group.com

Sales and Service Germany

EWM HIGHTEC WELDING GmbH
Lindenstraße 1a
38723 Seesen-Rhüden · Tel: +49 5384 90798-0 · Fax: -20
www.ewm-group.com/handel · nl-seesen@ewm-group.com

EWM Schweißtechnik-Handels-GmbH
Sachsstraße 28
50259 Pulheim · Tel: +49 2234 697-047 · Fax: -048
www.ewm-group.com/handel · nl-koeln@ewm-group.com

EWM HIGHTEC WELDING GmbH
In der Florinskaul 14-16
56218 Mülheim-Kärlich · Tel: +49 261 988898-0 · Fax: -20
www.ewm-group.com/handel · nl-muelheim@ewm-group.com

EWM Schweißtechnik-Handels-GmbH
Eiserfelder Straße 300
57080 Siegen · Tel: +49 271 3878103-0 · Fax: -9
www.ewm-group.com/handel · nl-siegen@ewm-group.com

EWM HIGHTEC WELDING GmbH
Vertriebs- und Technologiezentrum
Draisstraße 2a
69469 Weinheim · Tel: +49 6201 84557-0 · Fax: -20
www.ewm-group.com/handel · nl-weinheim@ewm-group.com

EWM Schweißtechnik Handels GmbH
Rittergasse 1
89143 Blaubeuren · Tel: +49 7344 9191-75 · Fax: -77
www.ewm-group.com/handel · nl-ulm@ewm-group.com

EWM Schweißtechnik Handels GmbH
Heinkelstraße 8
89231 Neu-Ulm · Tel: +49 731 7047939-0 · Fax: -15
www.ewm-group.com/handel · nl-ulm@ewm-group.com

EWM HIGHTEC WELDING AUTOMATION GmbH
Steinfeldstrasse 15
90425 Nürnberg · Tel: +49 911 3841-727 · Fax: -728
www.ewm-group.com/automation
automation-nl-nuernberg@ewm-group.com

Sales and Service International

EWM HIGHTEC WELDING GmbH
Fichtenweg 1
4810 Gmunden · Austria · Tel: +43 7612 778 02-0 · Fax: -20
www.ewm-group.com/at · info.at@ewm-group.com

EWM HIGHTEC WELDING UK Ltd.
Unit 2B Coopies Way · Coopies Lane Industrial Estate
Morpeth · Northumberland · NE61 6JN · Great Britain
Tel: +44 1670 505875 · Fax: -514305
www.ewm-group.com/uk · info.uk@ewm-group.com

EWM HIGHTEC WELDING (Kunshan) Ltd.
10 Yuanshan Road, Kunshan · New & High-tech Industry Development Zone
Kunshan · Jiangsu · 215300 · People's Republic of China
Tel: +86 512 57867-188 · Fax: -182
www.ewm-group.com/cn · info.cn@ewm-group.com

EWM HIGHTEC WELDING Sales s.r.o. / Prodejní a poradenské centrum
Tyršova 2106
256 01 Benešov u Prahy · Czech Republic
Tel: +420 317 729-517 · Fax: -712
www.ewm-group.com/cz · sales.cz@ewm-group.com

EWM HIGHTEC WELDING FZCO / Regional Office Middle East
LOB 21 G 16 · P.O. Box 262851
Jebel Ali Free Zone · Dubai, UAE · United Arab Emirates
Tel: +971 48870-322 · Fax: -323
www.ewm-group.com/me · info.me@ewm-group.com