



## Retrofit option

### **ON PS Trolley 55.2-2 drive 200/300C**

Pivot support - Wire feeder pivots 360° on the welding machine

# General instructions

## CAUTION



### **Read the operating instructions!**

**The operating instructions provide an introduction to the safe use of the products.**

- Read the operating instructions for all system components!
- Observe accident prevention regulations!
- Observe all local regulations!
- Confirm with a signature where appropriate.

## NOTE



**In the event of queries on installation, commissioning, operation or special conditions at the installation site, or on usage, please contact your sales partner or our customer service department on +49 2680 181-0.**

**A list of authorised sales partners can be found at [www.ewm-group.com](http://www.ewm-group.com).**

Liability relating to the operation of this equipment is restricted solely to the function of the equipment. No other form of liability, regardless of type, shall be accepted. This exclusion of liability shall be deemed accepted by the user on commissioning the equipment.

The manufacturer is unable to monitor whether or not these instructions or the conditions and methods are observed during installation, operation, usage and maintenance of the equipment.

An incorrectly performed installation can result in material damage and injure persons as a result. For this reason, we do not accept any responsibility or liability for losses, damages or costs arising from incorrect installation, improper operation or incorrect usage and maintenance or any actions connected to this in any way.

---

# 1 Contents

<b>1</b>	<b>Contents</b> .....	<b>3</b>
<b>2</b>	<b>Safety instructions</b> .....	<b>4</b>
<b>3</b>	<b>Overview</b> .....	<b>5</b>
3.1	Proper usage .....	5
3.2	Short description of the working steps required .....	5
3.3	Diagram of the assembled option .....	5
3.4	System overview.....	6
<b>4</b>	<b>Design and function</b> .....	<b>7</b>
4.1	Assembly .....	7
4.1.1	Mount wire feeder on to pivot support.....	8
4.2	Final assembly .....	9
<b>5</b>	<b>Technical data</b> .....	<b>9</b>

## 2 Safety instructions



### DANGER



**Do not carry out any unauthorised repairs or modifications!**

**To avoid injury and equipment damage, the unit must only be repaired or modified by specialist, skilled persons!**

**The warranty becomes null and void in the event of unauthorised interference.**

- Appoint only skilled persons for repair work (trained service personnel)!



### WARNING



**Validity of this document!**

**This document is only valid in combination with the operating instructions for the power source being used (welding machine)!**

- Read the operating instructions, in particular the safety instructions for the power source (welding machine)!



**Risk of accidents if these safety instructions are not observed!**

**Non-observance of these safety instructions is potentially fatal!**

- Carefully read the safety information in this manual!
- Observe the accident prevention regulations in your country.
- Inform persons in the working area that they must observe the regulations!

### CAUTION



**Obligations of the operator!**

**The respective national directives and laws must be observed for operation of the machine!**

- National implementation of the framework directive (89/391/EEG), as well as the associated individual directives.
- In particular, directive (89/655/EEG), on the minimum regulations for safety and health protection when staff members use equipment during work.
- The regulations regarding work safety and accident prevention for the respective country.
- Setting up and operating the machine according to IEC 60974-9.
- Check at regular intervals that users are working in a safety-conscious way.
- Regular checks of the machine according to IEC 60974-4.

### 3 Overview

#### 3.1 Proper usage

##### ⚠ WARNING



##### Hazards due to improper usage!

Hazards may arise for persons, animals and material objects if the equipment is not used correctly. No liability is accepted for any damages arising from improper usage!

- The equipment must only be used in line with proper usage and by trained or expert staff!
- Do not modify or convert the equipment improperly!

##### NOTE



##### This option can only be used in conjunction with the specified options and machine versions!

- ON PS drive 4L T/P (092-002112-00000)
- ON PS Trolley 55.2-2 drive 4L (092-002701-00000)
- ON TR Trolley 55.2-2 (092-002700-00000)

These instructions apply only for the conversion of the following machines:

- Taurus drive 200C / 300C
- Phoenix drive 200C / 300C

#### 3.2 Short description of the working steps required

- Mounting the console to an existing machine.

#### 3.3 Diagram of the assembled option

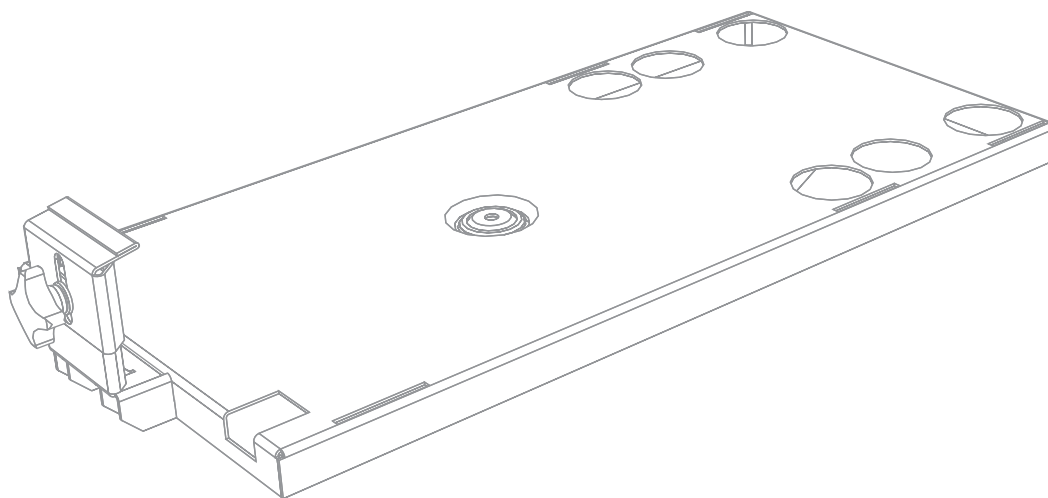

Figure 3-1

### 3.4 System overview

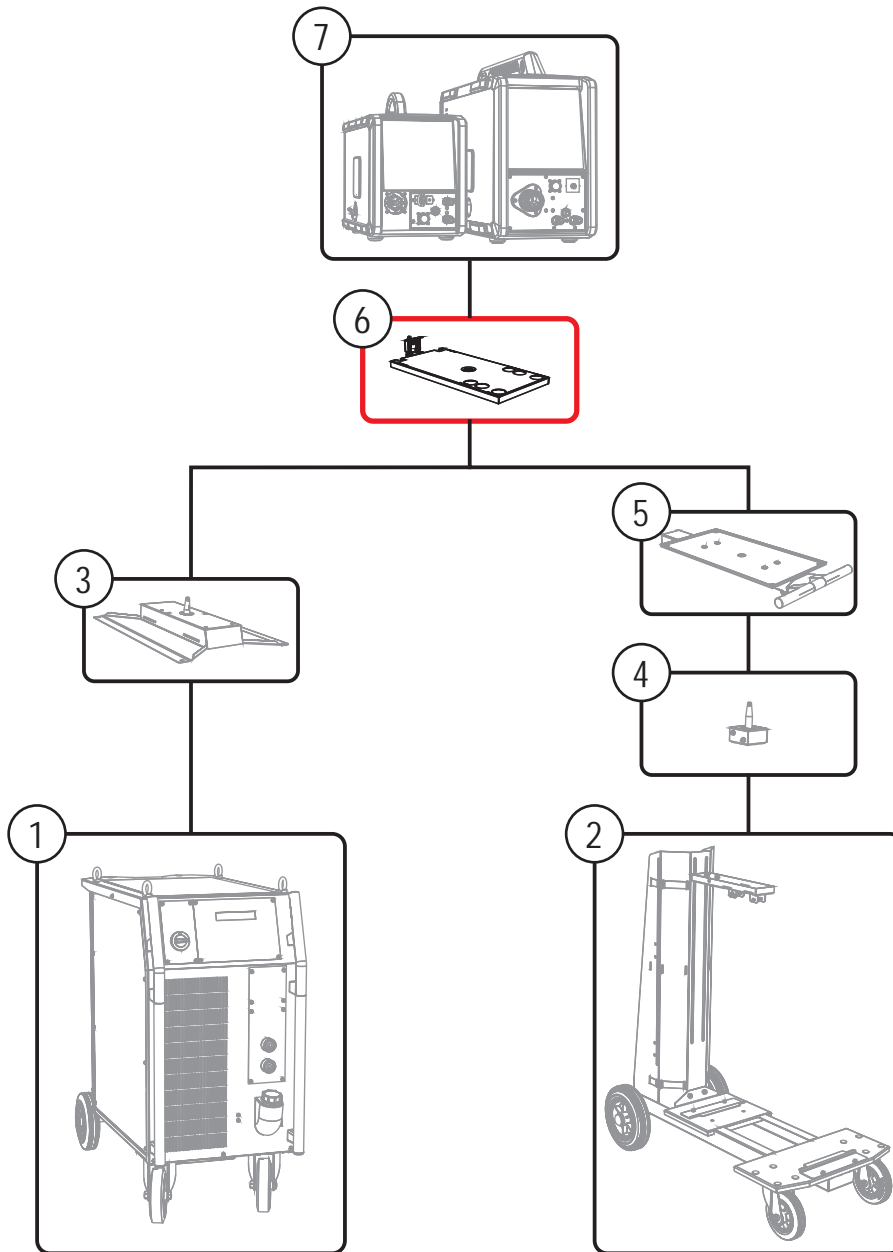

Figure 3-2

Item	Symbol	Description
1		<b>Power source</b>
2		<b>Transport vehicle - Trolley 55.2-2</b>
3		<b>ON PS drive 4L T/P</b> Pivot support – 092-002112-00000
4		<b>ON PS Trolley 55.2-2 drive 4L</b> Pivot support – 092-002701-00000
5		<b>ON TR Trolley 55.2-2</b> Cross arm and holder for wire feeder - 092-002700-00000
6		<b>ON PS Trolley 55.2-2 drive 200/300C</b> Pivot support - 092-002634-00000
7		<b>Wire feeders - drive 200/300C (pivotable)</b>

## 4 Design and function

### 4.1 Assembly

#### CAUTION



#### Improperly secured equipment!

Equipment, equipment combinations and accessories incorrectly fastened onto transport systems can tip over during transport and cause injuries!

- Only use the original parts supplied to fasten the equipment.
- Use the systems only for transporting the machines given in the "Intended use" chapter.
- Check the fixing points before each transport and at regular intervals.

#### NOTE



The illustration serves as an example only.

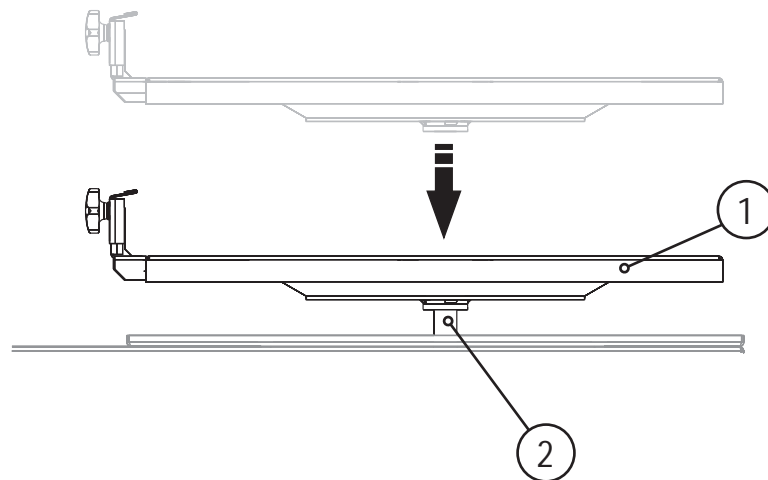

Figure 4-1

Item	Symbol	Description
1		<b>ON PS Trolley 55.2-2 drive 200/300C</b> Pivot support
2		<b>Arbor</b>

## 4.1.1 Mount wire feeder on to pivot support

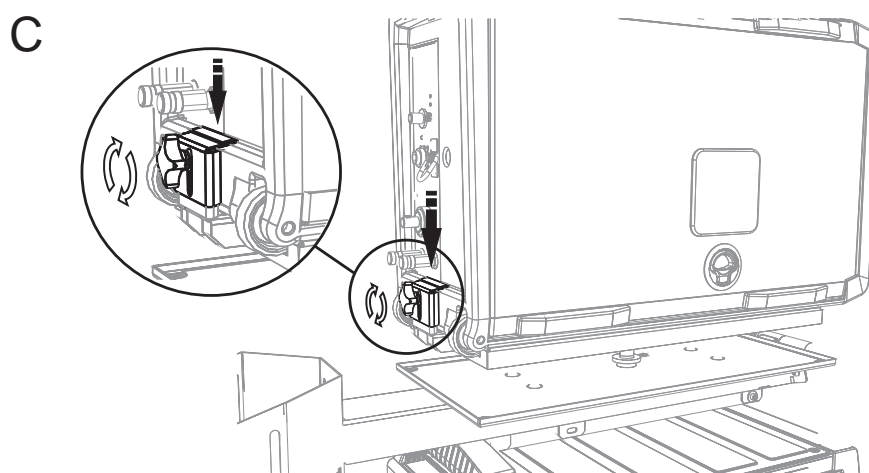
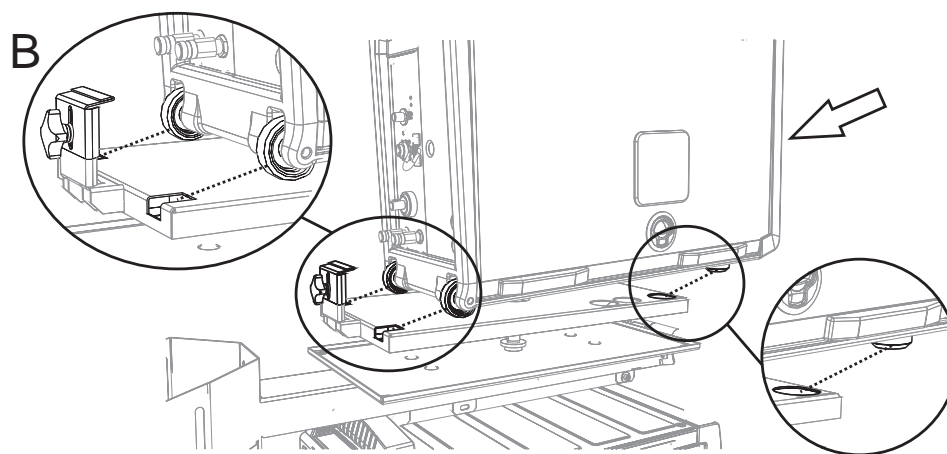
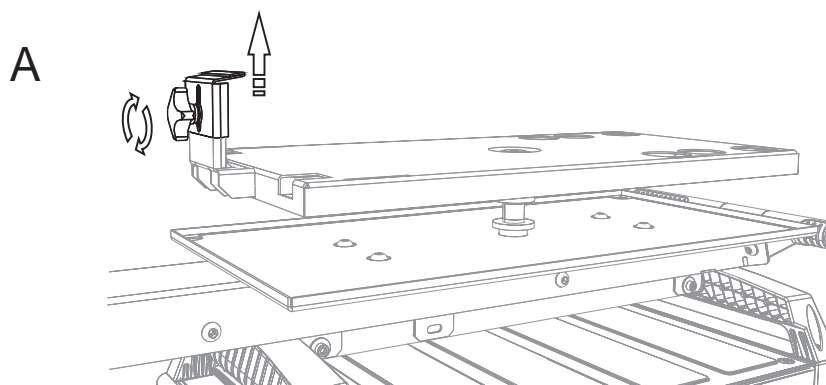

Figure 4-2



## 4.2 Final assembly

### WARNING



**Danger due to failure to carry out the final inspection!**

**Parts that are incorrectly fitted or that become loose are a source of danger.**

- Check all mechanical connections to ensure that they are fitted correctly!
- Carry out the final inspection!
- Carry out the functional test!

### NOTE



- **Keep the conversion instructions with the machine documentation!**
- **When ordering spare parts, ensure that the item number and serial number of the machine are quoted!**

## 5 Technical data

### NOTE



**The technical data given here completes or replaces the respective values in the standard operating instructions.**

- Weight: +3 kg