

# **OPERATING INSTRUCTIONS**

**for**

**Liquid Recooling System**

**Compact Units**

**03/04**

**Part number :**

The following instructions contains:

- " safety regulations
- " operating instructions
- " maintenance and repair instructions

This manual was written to enable the operator to operate and service the liquid recooling system.

These instructions are to be employed to familiarize the operator with the system, thus avoiding disruptions as the result of inexperienced operation. Observation of the maintenance instructions enhances the reliability, the service life and reduces repair costs and down times.

Always keep these instructions at the site at which the system is used. Operate the system only after familiarization training and comply with these instructions while doing so. It is imperative that you observe the safety regulations.

The company ETSCHIED will not be liable for the system's functions if it is not used for its intended purpose. You have no warranty claims in case of operating and erection errors, inadequate maintenance and incorrect circulating media. The declaration of manufacturer or conformity will also be rendered null and void.

Warranty and liability conditions in ETSCHIED's terms and conditions of business are extended by the aforementioned notes.

**Please enter** (obtain information from nameplate)

System No. \_\_\_\_\_

# TABLE OF CONTENTS

	Page		Page
<b>1. BRIEF INTRODUCTION</b>	<b>04</b>	<b>6. OPERATION</b>	<b>14</b>
1.1. Description	04	6.1. Commissioning	14
1.2. Connecting the system	04	6.2. Setting the temperature	15
1.3. Switching OFF the system	04	6.2.1. Mechanical thermostat	15
1.4. Switching ON the system	04	6.2.2. Digital thermostat	15
<b>2. SAFETY REGULATIONS</b>	<b>05</b>	6.3. More digital thermostat operations	16
<b>3. TECHNICAL SPECIFICATIONS</b>	<b>08</b>	<b>7. MAINTENANCE AND REPAIR</b>	<b>16</b>
3.1. General data	08	<b>8. MALFUNCTION / ERROR DIAGRAMS</b>	<b>17, 18</b>
3.2. Diagrams	09	<b>9. SPECIAL OPTIONS</b>	<b>18</b>
<b>4. DESCRIPTION</b>	<b>10</b>	9.1. Overview	18
4.1. General information	10	9.2. Description of the special options	19
4.2. Standard systems	10	<b>10. APPENDIX</b>	<b>21</b>
4.3. Special systems	10	10.1. Technical Data of the re cooler	21
4.4. Coolant circuit	10	10.2. List of components	22
4.5. Temperature control	11	10.3. Electric circuit diagram	22
4.6. Diagram	12	10.4. Test protocol	22
4.7. Sectional view	12		
<b>5. ASSEMBLY</b>	<b>13</b>		
5.1. Transportation	13		
5.2. Erection	13		
5.3. Installation	14		

# 1. BRIEF INTRODUCTION

## 1.1. Description

Type IK-V 07, IK-V 1.4/T and IK-V 2/T

- " are continuously operating systems to cool production machinery
- " operate at an ambient temperature up to about 32°C
- " feature a fully hermetically sealed compressor
- " attain a cooling capacity of 0.9 kW
- " have a pump installed as standard
- " cool at an inlet temperature of 10°C to 25°C as standard
- " only for indoor erection

**Note:** Take the special options into consideration.

## 1.2. Connecting the system

Connect system to mains as per regulations of your local power supply company and the information on the nameplate.

At your option, use hose or piping to make the connection to the system to be cooled (see page 14)

Note the operating pressures.

**Attention:** Do not turn on liquid recooling system until it has been connected on the water end and filled.  
The pump starts immediately when switched on.  
After long rest periods turn on the pump manually from the fan side before switching on the liquid cooler.

## 1.3. Turning OFF the system

- " Press ON/OFF switch. The display shows „OFF“ (digital thermostat), or turn master switch to „0“

## 1.4. Turning ON the system

- " Press ON/OFF switch. The display shows the actual temperature (digital thermostat), or turn master switch to „1“

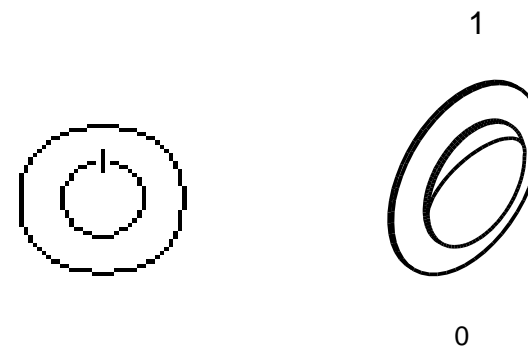

**Picture 1:** Digital thermostat

mechanical thermostat

## 2. SAFETY REGULATIONS

### Use for intended purpose

This ETSCHIED cooling system is constructed according to the state of the art and the applicable rules of technology.

The standard cooling system is only to be used to: cool cooling water or liquids with similar physical properties. No other liquids can be cooled without consulting the manufacturer.

### Use for purpose other than the one intended

This cooling system may be dangerous for persons and material resources, however, if

- " not used for the intended purpose
- " operated by untrained, technically incompetent personnel
- " improperly modified or remodelled
- " the safety regulations are not followed.

Consequently, everyone involved in the operation, maintenance or repair of the system must read and follow the operating instructions and, in particular, the safety regulations. In such a case this is to be confirmed through signature of the involved company.

Futhermore following has to be noticed and ovberserved:

- " pertinent regulations about accident protection, utilisation according to regulations
- " generally accepted rules, regulations from country to country.

### Who is permitted to operate the cooling system?

All technically competent, trained persons over 18 years of age who have been commissioned to do so may operate the cooling system. Maintenance and repair of electrical system components require special skills and must be performed by professionals.

### Remodelling and modifying the cooling system

For safety reasons, unauthorized modifications, attachments and remodelling of the cooling system are not permitted. The manufacturer also does not approve replacement parts and special fittings which it does not supply. Installation and/or utilization of such may affect the operational safety of the cooling system. The manufacturer refuses any liability whatsoever for damage resulting from using parts or special fittings which were not original equipment. Declarations of conformity or of the manufacturer and warranty claims lose their validity.

## 2. SAFETY REGULATIONS

### Transporting liquid recooling systems

Always transport liquid recooling systems in an upright position. Use only suitable means of conveyance and cranes with an adequate lifting capacity.

Use only loading ramps which can bear the load and are stable.

Secure the cooling system to prevent it from tipping or sliding.

Secure the cooling system on transport vehicles to prevent rolling, slipping and tipping.

**Mortal danger:** Do not walk under suspended loads!

### Erecting liquid recooling systems

Take the load-bearing capacity of the floor and necessary safety arrangements into consideration.

Do not erect the system near a source of heat.

Make certain there is an adequate supply of fresh air.

Erect system with at least 1 m wall distance from air intake and operating end.

### Starting the liquid recooling system

Before starting, familiarize yourself with the operating and control elements, the way the cooling system operates and the working environment.

Use personal safety gear.

Check to make certain that all protective devices are securely in place.

After long rest periods turn on the pump from the fan side manually before switching on the liquid cooler

Caution: Do not turn on cooling system with faulty instruments or control units.

Do not turn system on until water-end connection made and system filled.

### Maintenance and repairs

Caution: Disconnect system from power before performing any cleaning and repairs.

Permit only qualified persons who have been empowered to do so to perform repairs.

Perform maintenance and repairs only when drive at standstill. When exchanging relatively large modules and replacement parts, use only suitable and technically faultless cranes and load suspension devices with sufficient load-bearing capacity.

Replacement parts must conform with the technical requirements laid down by the manufacturer, so use only original replacement parts.

- " After all work, check all connections and joints for leaks.
- " Remedy any damage immediately.
- " After maintenance and repair, replace all protective devices properly and check them.

### 3. TECHNICAL SPECIFICATIONS

#### 3.1. General data

			①	①	①	①	①
			<b>IK-V 07</b>	<b>IK-V 1.4/T</b>	<b>IK-V 2/T</b>	<b>IK-V 3/T</b>	<b>IK-V 4/T</b>
①	Nominal power	kcal/h*	750	1400	1700	2750	3450
IK-V 07, 1.4 u. IK-V/T without	Nominal wattage	Watts	0,9	1600	2000	3200	4000
centralized fault indication	Level noise 3m away	dB(A)	57	57	57	57	64
IK-V 07 with mechan Thermostat	Lever noise 10m away	dB(A)	55	55	50	55	57
	Pump Type		LNY 2841	NPY 2051	NPY 2051	NPY 2051	NPY 2051
	Water tank capacity	Liters	5	15	15	15	15
	Pipe connection		DN 10	DN 10	DN 10	DN 10	DN 10
	Air flow rate	ml/h	600	1000	1000	2600	2600
	Compressor output	kW**	0,46	0,7	0,96	1,17	1,9
	Pump output	kW**	0,12	0,25	0,25	0,25	0,25
	Connected load	kW	0,6	1	1,3	1,6	2,3
	Voltage	V/Hz	1x230/N/PE/50	1x230/N/PE/50	1x230/N/PE/50	3x400/N/PE/50	3x400/N/PE/50
	Max. power	A	5,5	8	9,9	3,9	4,9
	Dimensions:Length	mm	565	750	750	750	750
	Width	mm	440	450	450	450	450
	Height	mm	345	500	500	500	500
	Approx. Weight	kg	42	85	85	85	85
	Collant charge	kg	0,35	0,65	0,76	1,1	1,1
Coolant IK-V 07 und IK-V/T: R 134a							

\* The mentioned cooling capacity refers to an ambient temperature of +32°C. The water inlet temperature is 15°C.

\*\* Nominal capacity according to manufacturer.

### 3. TECHNICAL SPECIFICATIONS

#### 3.2. Diagrams

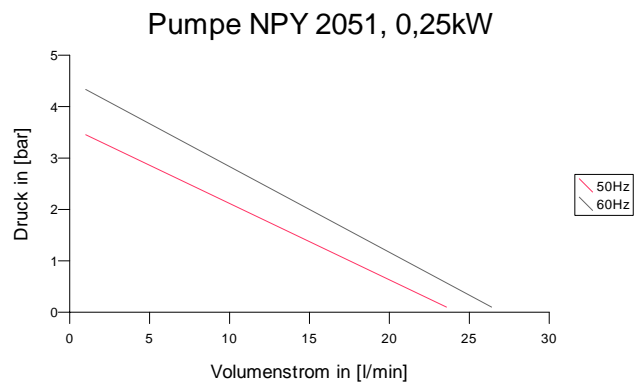
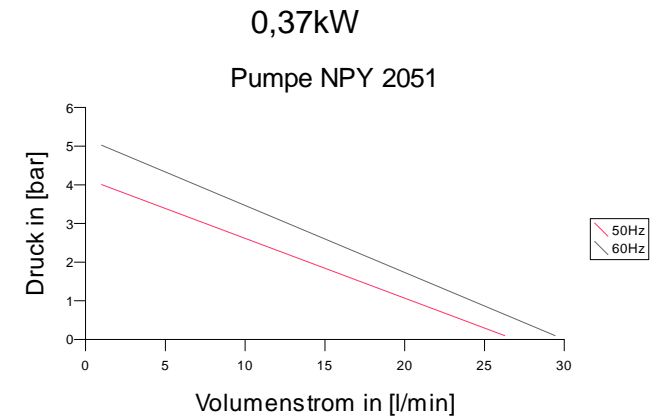
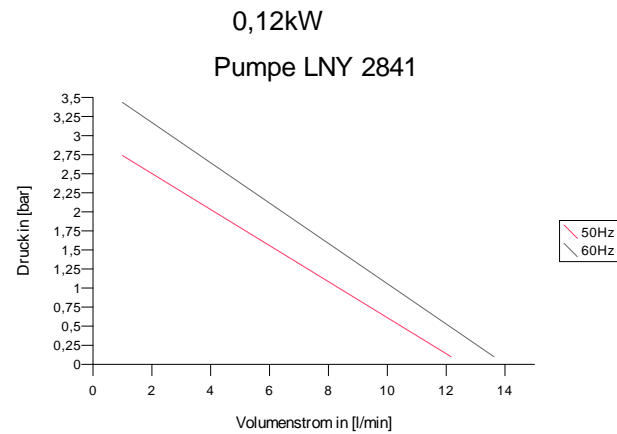

Figure 3: Pump diagram for special model

Figure 2: pump diagrams for standard models



## 4. DESCRIPTION

### 4.1. General information

The **Aqua Cooly** is a liquid recooling system. The system complies with the stipulations of the VDE with the stipulations of the VDE as well as those of VGB 20. The liquid recooling system is delivered as a compact, turnkey unit and can be put into service once electrical and piping connections to the system to be cooled have been made.

### 4.2. Standard systems

The data given on page 7 and/or the rating on the nameplate of the liquid recooling system are based on an ambient temperature of 25°C and a water inlet temperature of 15°C.

The cooling capacity declines with rising ambient temperature and falling water inlet temperature.

A pump moves the cooling water from the basin to the load.

An electronic thermostat monitors the temperature of the cooling water in the basin.

### 4.3. Special systems

At outlet temperatures < 10°C, additives must be put into the liquid recooling system or taken into consideration. Otherwise the system may sustain damage.

Antifreeze must be added if water inlet temperatures < 5°C.

### 4.4. Coolant circuit

The type IK-V liquid recooling system features a fully hermetically sealed motor compressor. This sucks the gaseous coolant from the evaporator and compresses the cooling gas to a pressure of to 18 bar with R134a and 27 bar with R404a. The gas enters the condenser downstream of the compressor at an elevated pressure and temperature.

In the standard model liquid recooling system this is an air-cooled condenser consisting of a laminated pipe structure. Fans suck the ambient air through this structure. This air cools and liquefies the gaseous coolant. The air passing through the condenser is heated and expelled as warm air.

The throttling process in the capillary tube reduces the coolant to a low pressure and temperature.

In the evaporator the coolant absorbs heat from the liquid to be cooled, completely evaporating in the process. As standard, the evaporator is a coil of tubing which is suspended in a basin.

### 4.5. Temperature control

All liquid recooling systems feature a thermostat which regulates the water inlet temperature.

This thermostat turns the cooling system

- " off when the preset water inlet temperature is reached
- " on again when the preset difference in temperature compared to the water inlet temperature is exceeded

## 4. DESCRIPTION

### 4.6. Diagram

- 1 Air-cooled condenser with axial fan
- 2 Fully hermetically sealed motor compressor
- 3 Evaporator indise
- 4 Capillare
- 5 Centrifugal pump
- 6 Evaporator basket
- 7 Insulated water basin
- 8 Thermostat

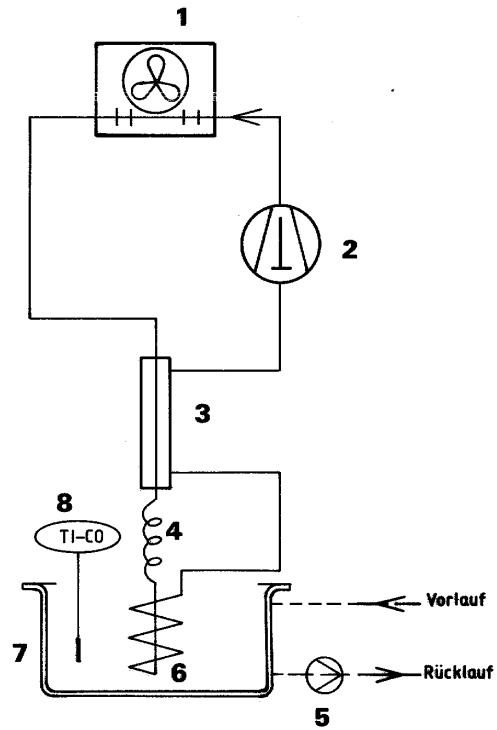

Figure 5: Diagram IK-V 07

## 4. DESCRIPTION

### 4.7. Sectional view

- |                       |                                 |
|-----------------------|---------------------------------|
| 1 Inlet line (Return) | 2 Outlet line                   |
| 3 Digital thermostate | 4 Tank with waterfilling (Feed) |
| 5 Drying chamber      | 6 Condenser                     |
| 7 Fan with protection | 8 Compressor                    |
| 9 Pump                | 10 Mains wiring cable           |

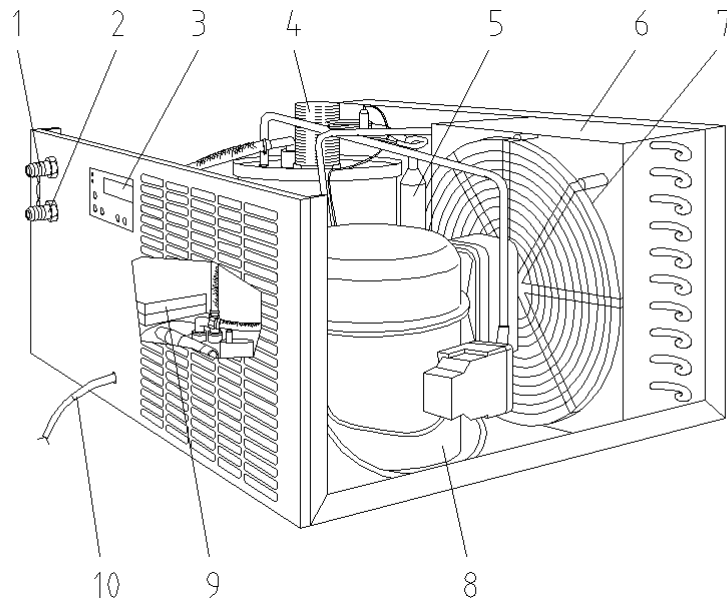

Figure 6: Sectional view of IK-V 07/C

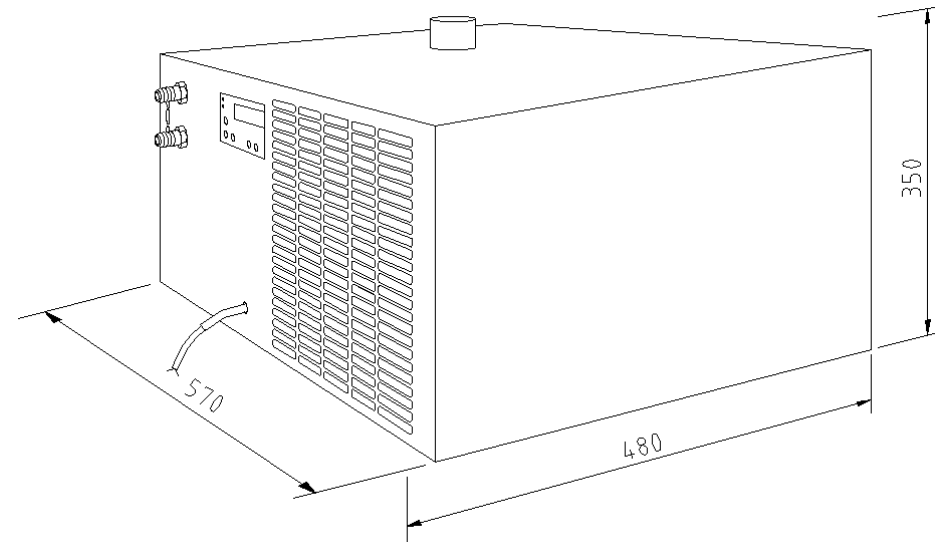

Figure 7: Dimensional drawing IK-V 07/C in „mm“

## 5. ASSEMBLY

### 5.1. Transportation

Liquid recooling systems are always transported in a upright position. Use only suitable means of conveyance and cranes with an adequate lifting capacity.

Use only loading ramps which can bear the load and are stable.

Secure the cooling system to prevent it from tipping or sliding.

Secure cooling system on transport vehicles to prevent rolling, slipping and tipping.

**Mortal danger:** Do not walk under suspended loads!

### 5.2. Erection

Liquid recooling systems are compact units, wired ready for connection.

**Attention:** Do not erect standard system outdoors.

Take the load bearing capacity of the floor and necessary safety arrangements into consideration.

Do not erect the system near a source of heat.

Make certain there is an adequate supply of fresh air.

Erect system with at least 1 m wall distance from air intake and operating end.

When loads are connected which feature an open cooling circuit or an cooling circuit which can be opened (e.g. for maintenance purposes):

If the machine to be cooled is on a lower level than the liquid recooling system, there is the risk that the tank in the liquid container will be emptied (Fig. 12),

If the machine to be cooled is on a higher level than the liquid recooling system, there is the risk that the tank in the recooling system will overflow.

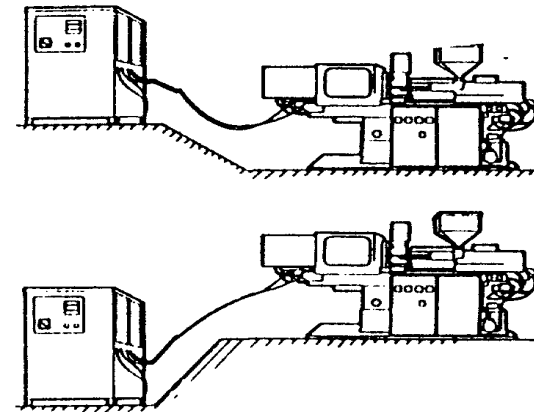

Figure 12: Erection

## 6. ASSEMBLY

### 6.3. Installation

Connect the system in accordance with

- " the regulations of your local power supply company
- " data on the nameplate.

1. Make the electrical connection.
2. Fill water into the water basin until the mark „Max.“ is reached.
3. Connect inlet line with cooling water inlet to load.
4. Connect return line with cooling water outlet to load.

#### Attention:

Where long distances are involved, insulate the liquid lines.

Take connection cross-sections and operating pressures into account.  
In case of piping more than 10 m long, select large pipe connection.  
Where applicable, consult the manufacturer.

## 6. OPERATION

### 6.1. Commissioning

1. Fill the basin.
2. Turn on the system (Press ON/OFF switch or master switch to "1")  
**Attention:** Do not turn on until system is filled!
3. Check the the fan turning in cooling mode.
4. Turn off the liquid recooling system (Press ON/OFF switch or master switch to "0")

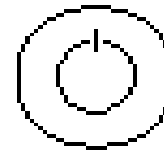

Picture 8: ON / OFF switch,  
digital thermostat

ON / OFF Switch IK-V 07/B  
mech. thermostat

## 6. OPERATION

### 6.2. Setting the temperature

#### 6.2.1. Mechanical thermostat

- " Measure the basin temperature with a customary temperature-measuring instrument.
- " Adjust the demanded temperature with the attachment screw on the mechanical thermostat:
  - Turn clockwise: temperature rises.
  - Turn counterclockwise: temperature falls.

#### 6.2.2 Digital thermostat (ST 501)



- " Press setpoint button (pic. 9/5): Display switches from actual value to setpoint.



- " Simultaneous press the arrow buttons  $\Delta$  or  $\nabla$  (pic. 9/6 and 9/7) to set the setpoint. The temperature set changes in increments of 0,1°C.

**Attention:** In the case of standard systems, the setpoint to be set **must** be between 10°C and 25°C. Don't change any parameters without talking to the manufacturer.

**Note:** In the case of special models, refer to the technical specifications on page 8.

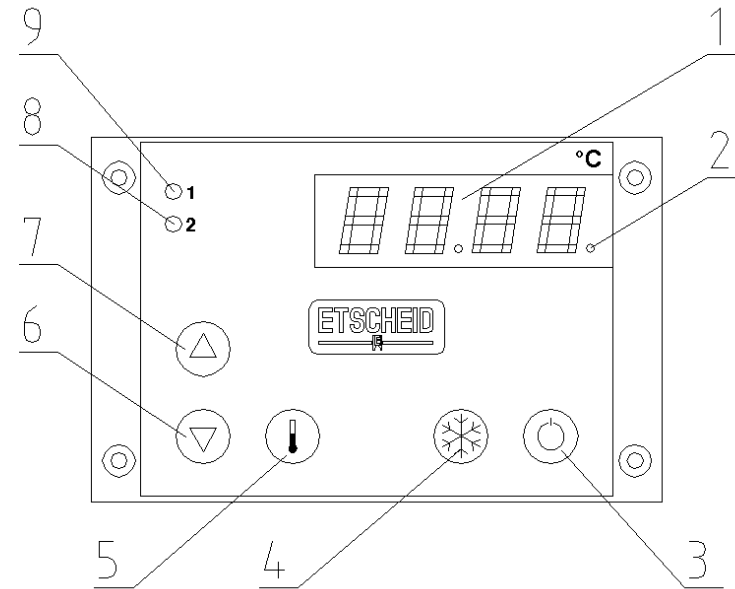

**Bild 9: Digital thermostat ST 501**

1. Temperature Display
2. Compressor-LED: (LED blinking: Compressor is switched off)
3. ON / OFF Switch (Standby)
4. Compressor ON / OFF Switch
5. Setpoint Switch
6. Temperature decrease
7. Temperature increase
8. LED Pump-Relais, ON / OFF
9. LED Compressor-Relais, ON / OFF

## 6. OPERATION

### 6.3. More digital thermostat operations



- " ON/OFF or Standby switch. After pressing this button (pic. 9/3), the display temperature appears. LED 2 (pic. 9/8) for the pump-function lights immediately. If the actual temperature outside the hysteresis, LED 1 (pic. 9/9) appears after a few seconds and the compressor (cooling) starts. Press the switch again and the cooling unit is OFF or in standby mode. The display shows OFF.



- " By pressing the compressor button (pic. 9/4), the compressor can be switched off. In the right corner of the display appears a blinking LED (pic. 9/2). LED 1 (pic. 9/9) is off. By pressing the button again, the LED in the right corner of the display stops blinking and the compressor starts again, if the actual temperature is higher than the setpoint. LED 1 (pic. 9/9) is on.
- " After switching the thermostat ON with the ON/OFF button (pic. 9/3), the pump and the compressor always start together.
- " After a current or voltage cut-off, the thermostat will start in the same mode as before the cut-off.

## 7. MAINTENANCE AND REPAIR

**Caution:** Disconnect system from power before cleaning and repair..

Clean air-cooled ribbed condenser at least once annually.

1. Carefully cover interior and bottom plate.
2. Blow out ribbed condenser with compressed air.

**Note:** If condenser is extremely dirty, clean it more frequently.

All other components are maintenance-free.

Perform maintenance work and repairs only when drive at standstill. Permit only qualified persons who have been empowered to do so to perform repairs.

Perform maintenance and repairs only when drive at standstill. When exchanging relatively large modules and replacement parts, use only suitable and technically faultless cranes and load suspension devices with sufficient load-bearing capacity.

Replacement parts must conform with the technical requirements laid down by the manufacturer, so use only original replacement parts.

- " After all work, check all connections and joints for leaks.
- " Remedy any damage immediately.
- " After maintenance and repair, replace all protective devices properly and check them.





## 8. MALFUNCTIONS / FAULT DIAGNOSIS

IK-V 1.4/T and IK-V 2/T contain a security pressure switch for high pressure.

In the case of a fault, a red fault lamp beside the thermostat will light.

Fault Diagnosis:

- \* high room temperature
- \* fan is not working
- \* temperature of cooling water is too high

The high pressure security will reset by itself, if the fault disappears.

## 9. SPECIAL OPTIONS

### 9.1. Overview

Article-No.	Name	Page
715 021	<b>Pressure-dependent bypass valve in inlet line</b> IK-V 07 to IK-V 1.4/T	19
715 031	<b>Bypass line with 2 sleeve slide valves in the inlet line</b> IK-V 07 to IK-V 4/T	19
715052	<b>Flow control</b> (flow-rate >3l/min) contacts on an extra line	20
715 201	<b>Evaporator in stainless steel IK-V 07</b>	20
715 228	<b>Water tubing in stainless steel IK-V 07</b>	20
715 101	<b>Insulation for low temperatures</b> (incl. cooling water tube, pump, suction pipe cooling unit (from -5°C inlet temperature, double insulation)	20
715 199	<b>Pump for deionized water</b>	20

## 9. SPECIAL OPTIONS

### 9.2. Description of special options

#### Pressure-dependent bypass valve in the inlet line

If the pressure higher than the pressure set at the bypass valve develops, the valve opens. The excess water flows back into the tank via the bypass line. This prevents the pump from coming up against a closed valve.

Recommended use in liquid recooling systems

- which are connected to loads where high pressure fluctuations are to be anticipated
- to which a number of loads are connected and which can be blocked at the factory
- for changeable setting of the volumetric flow.

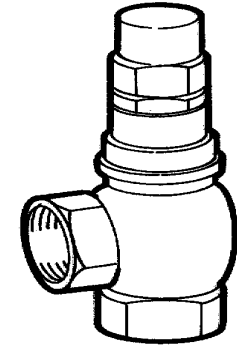
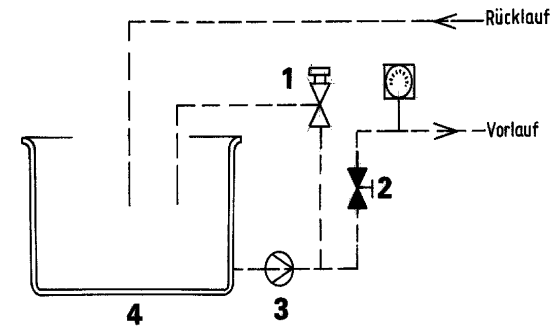

#### Bypass line with two sleeve slide valves in the inlet line

By using the two sleeve slide valves it is possible to preset the pressure and volumetric flow of coolant.

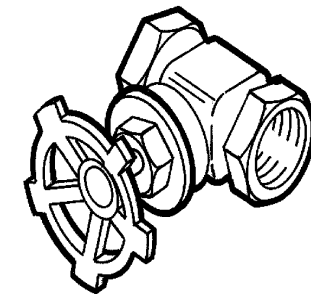
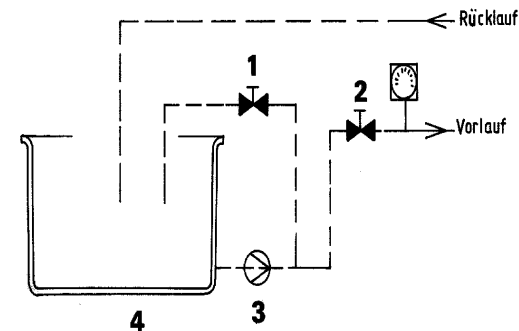

## 9. SPECIAL OPTIONS

### Flow control

Flow control monitors constantly check the flow rate of the coolant and transmit an alarm signal if the actual rate rises above or drops below the set rate.

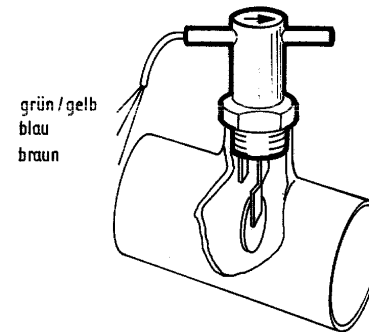

### Evaporator and water piping made of high-quality steel

Evaporator and water piping made of high-quality steel are necessary if

- deionized water is used as a coolant
- the cooling water contains corrosive materials
- the coolant is slightly corrosive .

### Insulation against condensation

In the case of cooling water and/or evaporation temperatures of the coolant under 10°C

- the cold side of the suction line
- and the water piping and pump

must be insulated to prevent the formation of condensation.

### Pump for deionized water type NPY 2051

## **10. APPENDIX**

**11.1. Technical data of the re cooler**

11.2. list of components