



Wire feed unit

Pico drive 4L

General instructions

CAUTION



Read the operating instructions!

The operating instructions provide an introduction to the safe use of the products.

- Read the operating instructions for all system components!
- Observe accident prevention regulations!
- Observe all local regulations!
- Confirm with a signature where appropriate.

NOTE



In the event of queries on installation, commissioning, operation or special conditions at the installation site, or on usage, please contact your sales partner or our customer service department on +49 2680 181-0.

A list of authorised sales partners can be found at www.ewm-group.com.

Liability relating to the operation of this equipment is restricted solely to the function of the equipment. No other form of liability, regardless of type, shall be accepted. This exclusion of liability shall be deemed accepted by the user on commissioning the equipment.

The manufacturer is unable to monitor whether or not these instructions or the conditions and methods are observed during installation, operation, usage and maintenance of the equipment.

An incorrectly performed installation can result in material damage and injure persons as a result. For this reason, we do not accept any responsibility or liability for losses, damages or costs arising from incorrect installation, improper operation or incorrect usage and maintenance or any actions connected to this in any way.

1 Contents

1	Contents	3
2	Safety instructions	5
2.1	Notes on the use of these operating instructions	5
2.2	Explanation of icons	6
2.3	General	7
2.4	Transport and installation	11
2.4.1	Ambient conditions	12
2.4.1.1	In operation	12
2.4.1.2	Transport and storage	12
3	Intended use	13
3.1	Applications	13
3.1.1	MIG/MAG standard welding	13
3.2	Use and operation solely with the following machines	13
3.3	Documents which also apply	14
3.3.1	Warranty	14
3.3.2	Declaration of Conformity	14
3.3.3	Welding in environments with increased electrical hazards	14
3.3.4	Service documents (spare parts and circuit diagrams)	14
3.3.5	Calibration/Validation	14
4	Machine description – quick overview	15
4.1	Front view	15
4.2	Rear view	16
4.3	Inside view	17
4.3.1	Internal operating elements	18
4.4	Machine control – Operating elements	19
4.4.1	Setting the operating point (welding output)	20
5	Design and function	21
5.1	General	21
5.2	Transport and installation	22
5.3	Notes on the installation of welding current leads	23
5.4	Shielding gas supply (shielding gas cylinder for welding machine)	24
5.4.1	Gas test	24
5.4.2	Setting the shielding gas quantity	24
5.5	Intermediate hose package connection	25
5.6	Welding torch connection	26
5.7	Wire feed	27
5.7.1	Open the protective flap of the wire feeder	27
5.7.2	Inserting the wire spool	27
5.7.3	Changing the wire feed rollers	28
5.7.4	Inching the wire electrode	29
5.7.5	Spool brake setting	31
5.8	MIG/MAG functional sequences / operating modes	32
5.8.1	Explanation of signs and functions	32
5.8.2	Non-latched mode	33
5.8.3	Latched mode	34
5.8.4	MIG/MAG automatic cut-out	34

6	Maintenance, care and disposal	35
6.1	General.....	35
6.2	Maintenance work, intervals.....	35
6.2.1	Daily maintenance tasks.....	35
6.2.1.1	Visual inspection	35
6.2.1.2	Functional test	35
6.2.2	Monthly maintenance tasks	36
6.2.2.1	Visual inspection	36
6.2.2.2	Functional test	36
6.2.3	Annual test (inspection and testing during operation)	36
6.3	Maintenance work	36
6.4	Disposing of equipment.....	37
6.4.1	Manufacturer's declaration to the end user	37
6.5	Meeting the requirements of RoHS.....	37
7	Rectifying faults.....	38
7.1	Checklist for rectifying faults	38
8	Technical data.....	39
9	Accessories	40
9.1	General accessories	40
9.2	Options.....	40
10	Replaceable parts.....	41
10.1	Wire feed rollers	41
10.1.1	Wire feed rollers for steel wire	41
10.1.2	Wire feed rollers for aluminium wire	41
10.1.3	Wire feed rollers for cored wire.....	41
10.1.4	Conversion sets	42
11	Appendix A.....	43
11.1	Overview of EWM branches.....	43

2 Safety instructions

2.1 Notes on the use of these operating instructions

DANGER

Working or operating procedures which must be closely observed to prevent imminent serious and even fatal injuries.

- Safety notes include the "DANGER" keyword in the heading with a general warning symbol.
- The hazard is also highlighted using a symbol on the edge of the page.

WARNING

Working or operating procedures which must be closely observed to prevent serious and even fatal injuries.

- Safety notes include the "WARNING" keyword in the heading with a general warning symbol.
- The hazard is also highlighted using a symbol in the page margin.

CAUTION

Working or operating procedures which must be closely observed to prevent possible minor personal injury.

- The safety information includes the "CAUTION" keyword in its heading with a general warning symbol.
- The risk is explained using a symbol on the edge of the page.

CAUTION

Working and operating procedures which must be followed precisely to avoid damaging or destroying the product.

- The safety information includes the "CAUTION" keyword in its heading without a general warning symbol.
- The hazard is explained using a symbol at the edge of the page.

NOTE













Special technical points which users must observe.

- Notes include the "NOTE" keyword in the heading without a general warning symbol.

Instructions and lists detailing step-by-step actions for given situations can be recognised via bullet points, e.g.:

- Insert the welding current lead socket into the relevant socket and lock.

2.2 Explanation of icons

Symbol	Description
	Press
	Do not press
	Turn
	Switch
	Switch off machine
	Switch on machine
	ENTER (enter the menu)
	NAVIGATION (Navigating in the menu)
	EXIT (Exit the menu)
	Time display (example: wait 4s/press)
	Interruption in the menu display (other setting options possible)
	Tool not required/do not use
	Tool required/use

2.3 General

DANGER



Electromagnetic fields!

The power source may cause electrical or electromagnetic fields to be produced which could affect the correct functioning of electronic equipment such as IT or CNC devices, telecommunication lines, power cables, signal lines and pacemakers.

- Observe the maintenance instructions! (see Maintenance and Testing chapter)
- Unwind welding leads completely!
- Shield devices or equipment sensitive to radiation accordingly!
- The correct functioning of pacemakers may be affected (obtain advice from a doctor if necessary).



Do not carry out any unauthorised repairs or modifications!

To avoid injury and equipment damage, the unit must only be repaired or modified by specialist, skilled persons!

The warranty becomes null and void in the event of unauthorised interference.

- Appoint only skilled persons for repair work (trained service personnel)!



Electric shock!

Welding machines use high voltages which can result in potentially fatal electric shocks and burns on contact. Even low voltages can cause you to get a shock and lead to accidents.

- Do not touch any live parts in or on the machine!
- Connection cables and leads must be free of faults!
- Switching off alone is not sufficient!
- Place welding torch and stick electrode holder on an insulated surface!
- The unit should only be opened by specialist staff after the mains plug has been unplugged!
- Only wear dry protective clothing!
- Wait for 4 minutes until the capacitors have discharged!

WARNING



Validity of this document!

This document is only valid in combination with the operating instructions for the power source being used (welding machine)!

- Read the operating instructions, in particular the safety instructions for the power source (welding machine)!



Risk of accidents if these safety instructions are not observed!

Non-observance of these safety instructions is potentially fatal!

- Carefully read the safety information in this manual!
- Observe the accident prevention regulations in your country.
- Inform persons in the working area that they must observe the regulations!



Explosion risk!

Apparently harmless substances in closed containers may generate excessive pressure when heated.

- Move containers with inflammable or explosive liquids away from the working area!
- Never heat explosive liquids, dusts or gases by welding or cutting!

WARNING



Risk of injury due to radiation or heat!

Arc radiation results in injury to skin and eyes.

Contact with hot workpieces and sparks results in burns.

- Use welding shield or welding helmet with the appropriate safety level (depending on the application)!
- Wear dry protective clothing (e.g. welding shield, gloves, etc.) according to the relevant regulations in the country in question!
- Protect persons not involved in the work against arc beams and the risk of glare using safety curtains!



Smoke and gases!

Smoke and gases can lead to breathing difficulties and poisoning. In addition, solvent vapour (chlorinated hydrocarbon) may be converted into poisonous phosgene due to the ultraviolet radiation of the arc!

- Ensure that there is sufficient fresh air!
- Keep solvent vapour away from the arc beam field!
- Wear suitable breathing apparatus if appropriate!



Fire hazard!

Flames may arise as a result of the high temperatures, stray sparks, glowing-hot parts and hot slag produced during the welding process.

Stray welding currents can also result in flames forming!

- Check for fire hazards in the working area!
- Do not carry any easily flammable objects such as matches or lighters.
- Keep appropriate fire extinguishing equipment to hand in the working area!
- Thoroughly remove any residue of flammable substances from the workpiece before starting welding.
- Only continue work on welded workpieces once they have cooled down.
Do not allow to come into contact with flammable material!
- Connect welding leads correctly!



Danger when coupling multiple power sources!

Coupling multiple power sources in parallel or in series has to be carried out by qualified personnel and in accordance with the manufacturer's guidelines. Before bringing the power sources into service for arc welding operations, a test has to verify that they cannot exceed the maximum allowed open circuit voltage.

- Connection of the machine may be carried out by qualified personnel only!
- When decommissioning individual power sources, all mains and welding current leads have to be safely disconnected from the welding system as a whole. (danger due to inverse voltages)!

CAUTION



Noise exposure!

Noise exceeding 70 dBA can cause permanent hearing damage!

- Wear suitable ear protection!
- Persons located within the working area must wear suitable ear protection!

CAUTION**Obligations of the operator!**

The respective national directives and laws must be observed for operation of the machine!

- National implementation of the framework directive (89/391/EEG), as well as the associated individual directives.
- In particular, directive (89/655/EEG), on the minimum regulations for safety and health protection when staff members use equipment during work.
- The regulations regarding work safety and accident prevention for the respective country.
- Setting up and operating the machine according to IEC 60974-9.
- Check at regular intervals that users are working in a safety-conscious way.
- Regular checks of the machine according to IEC 60974-4.

**Damage due to the use of non-genuine parts!**

The manufacturer's warranty becomes void if non-genuine parts are used!

- Only use system components and options (power sources, welding torches, electrode holders, remote controls, spare parts and replacement parts, etc.) from our range of products!
- Only insert and lock accessory components into the relevant connection socket when the machine is switched off.

**Damage to the machine due to stray welding currents!**

Stray welding currents can destroy protective earth conductors, damage equipment and electronic devices and cause overheating of components leading to fire.

- Make sure all welding leads are securely connected and check regularly.
- Always ensure a proper and secure electrical connection to the workpiece!
- Set up, attach or suspend all conductive power source components like casing, transport vehicle and crane frames so they are insulated!
- Do not place any other electronic devices such as drillers or angle grinders, etc., on the power source, transport vehicle or crane frames unless they are insulated!
- Always put welding torches and electrode holders on an insulated surface when they are not in use!

**Mains connection****Requirements for connection to the public mains network**

High-performance machines can influence the mains quality by taking current from the mains network. For some types of machines, connection restrictions or requirements relating to the maximum possible line impedance or the necessary minimum supply capacity at the interface with the public network (Point of Common Coupling, PCC) can therefore apply. In this respect, attention is also drawn to the machines' technical data. In this case, it is the responsibility of the operator, where necessary in consultation with the mains network operator, to ensure that the machine can be connected.

CAUTION



EMC Machine Classification

In accordance with IEC 60974-10, welding machines are grouped in two electromagnetic compatibility classes (see technical data):

Class A machines are not intended for use in residential areas where the power supply comes from the low-voltage public mains network. When ensuring the electromagnetic compatibility of class A machines, difficulties can arise in these areas due to interference not only in the supply lines but also in the form of radiated interference.

Class B machines fulfil the EMC requirements in industrial as well as residential areas, including residential areas connected to the low-voltage public mains network.

Setting up and operating

When operating arc welding systems, in some cases, electro-magnetic interference can occur although all of the welding machines comply with the emission limits specified in the standard. The user is responsible for any interference caused by welding.

In order to **evaluate** any possible problems with electromagnetic compatibility in the surrounding area, the user must consider the following: (see also EN 60974-10 Appendix A)

- Mains, control, signal and telecommunication lines
- Radios and televisions
- Computers and other control systems
- Safety equipment
- The health of neighbouring persons, especially if they have a pacemaker or wear a hearing aid
- Calibration and measuring equipment
- The immunity to interference of other equipment in the surrounding area
- The time of day at which the welding work must be carried out

Recommendations for **reducing interference emission**

- Mains connection, e.g. additional mains filter or shielding with a metal tube
- Maintenance of the arc welding equipment
- Welding leads should be as short as possible and run closely together along the ground
- Potential equalization
- Earthing of the workpiece. In cases where it is not possible to earth the workpiece directly, it should be connected by means of suitable capacitors.
- Shielding from other equipment in the surrounding area or the entire welding system

2.4 Transport and installation

WARNING



Incorrect handling of shielding gas cylinders!

Incorrect handling of shielding gas cylinders can result in serious and even fatal injury.

- Observe the instructions from the gas manufacturer and in any relevant regulations concerning the use of compressed air!
- Place shielding gas cylinders in the holders provided for them and secure with fixing devices.
- Avoid heating the shielding gas cylinder!



Risk of accident due to improper transport of machines that may not be lifted!

Do not lift or suspend the machine! The machine can fall down and cause injuries! The handles and brackets are suitable for transport by hand only!

- The machine may not be lifted by crane or suspended!

CAUTION



Risk of tipping!

There is a risk of the machine tipping over and injuring persons or being damaged itself during movement and set up. Tilt resistance is guaranteed up to an angle of 10° (according to IEC 60974-1).

- Set up and transport the machine on level, solid ground.
- Secure add-on parts using suitable equipment.



Damage due to supply lines not being disconnected!

During transport, supply lines which have not been disconnected (mains supply leads, control leads, etc.) may cause hazards such as connected equipment tipping over and injuring persons!

- Disconnect supply lines!

CAUTION



Equipment damage when not operated in an upright position!

The units are designed for operation in an upright position!

Operation in non-permissible positions can cause equipment damage.

- Only transport and operate in an upright position!

2.4.1 Ambient conditions

CAUTION



Installation site!

The machine must not be operated in the open air and must only be set up and operated on a suitable, stable and level base!

- The operator must ensure that the ground is non-slip and level, and provide sufficient lighting for the place of work.
- Safe operation of the machine must be guaranteed at all times.

CAUTION



Equipment damage due to dirt accumulation!

Unusually high quantities of dust, acid, corrosive gases or substances may damage the equipment.

- Avoid high volumes of smoke, vapour, oil vapour and grinding dust!
- Avoid ambient air containing salt (sea air)!



Non-permissible ambient conditions!

Insufficient ventilation results in a reduction in performance and equipment damage.

- Observe the ambient conditions!
- Keep the cooling air inlet and outlet clear!
- Observe the minimum distance of 0.5 m from obstacles!

2.4.1.1 In operation

Temperature range of the ambient air:

- -25 °C to +40 °C

Relative air humidity:

- Up to 50% at 40 °C
- Up to 90% at 20 °C

2.4.1.2 Transport and storage

Storage in an enclosed space, temperature range of the ambient air:

- -30 °C to +70 °C

Relative air humidity

- Up to 90% at 20 °C

3 Intended use

WARNING



Hazards due to improper usage!

Hazards may arise for persons, animals and material objects if the equipment is not used correctly. No liability is accepted for any damages arising from improper usage!

- The equipment must only be used in line with proper usage and by trained or expert staff!
- Do not modify or convert the equipment improperly!

3.1 Applications

3.1.1 MIG/MAG standard welding

Metal arc welding using a wire electrode whereby gas from an external source surrounds the arc and the molten pool to protect them from the atmosphere.

Welding with cored wire electrodes consisting of a metal casing and a powder core.

As with MIG/MAG standard welding, the arc is protected from the atmosphere by shielding gas. The gas is supplied either externally (gas shielded cored wires) or produced in the arc by means of the powder core (self-shielding cored wires).

3.2 Use and operation solely with the following machines

NOTE



A suitable power source (system component) is required in order to operate the wire feed unit!

	Pico drive 4L	Pico drive 200C
Pico 350		<input checked="" type="checkbox"/>

3.3 Documents which also apply

3.3.1 Warranty

NOTE



For further information, please see the accompanying supplementary sheets "Machine and Company Data, Maintenance and Testing, Warranty"!

3.3.2 Declaration of Conformity



The designated machine conforms to EC Directives and standards in terms of its design and construction:

- EC Low Voltage Directive (2006/95/EC),
- EC EMC Directive (2004/108/EC),

This declaration shall become null and void in the event of unauthorised modifications, improperly conducted repairs, non-observance of the deadlines for the repetition test and / or non-permitted conversion work not specifically authorised by the manufacturer.

The original copy of the declaration of conformity is enclosed with the unit.

3.3.3 Welding in environments with increased electrical hazards



In compliance with IEC / DIN EN 60974, VDE 0544 the machines can be used in environments with an increased electrical hazard.

3.3.4 Service documents (spare parts and circuit diagrams)



DANGER



Do not carry out any unauthorised repairs or modifications!

To avoid injury and equipment damage, the unit must only be repaired or modified by specialist, skilled persons!

The warranty becomes null and void in the event of unauthorised interference.

- Appoint only skilled persons for repair work (trained service personnel)!

Original copies of the circuit diagrams are enclosed with the unit.

Spare parts can be obtained from the relevant authorised dealer.

3.3.5 Calibration/Validation

We hereby confirm that this machine has been tested using calibrated measuring equipment, as stipulated in IEC/EN 60974, ISO/EN 17662, EN 50504, and complies with the admissible tolerances. Recommended calibration interval: 12 months

4 Machine description – quick overview

4.1 Front view

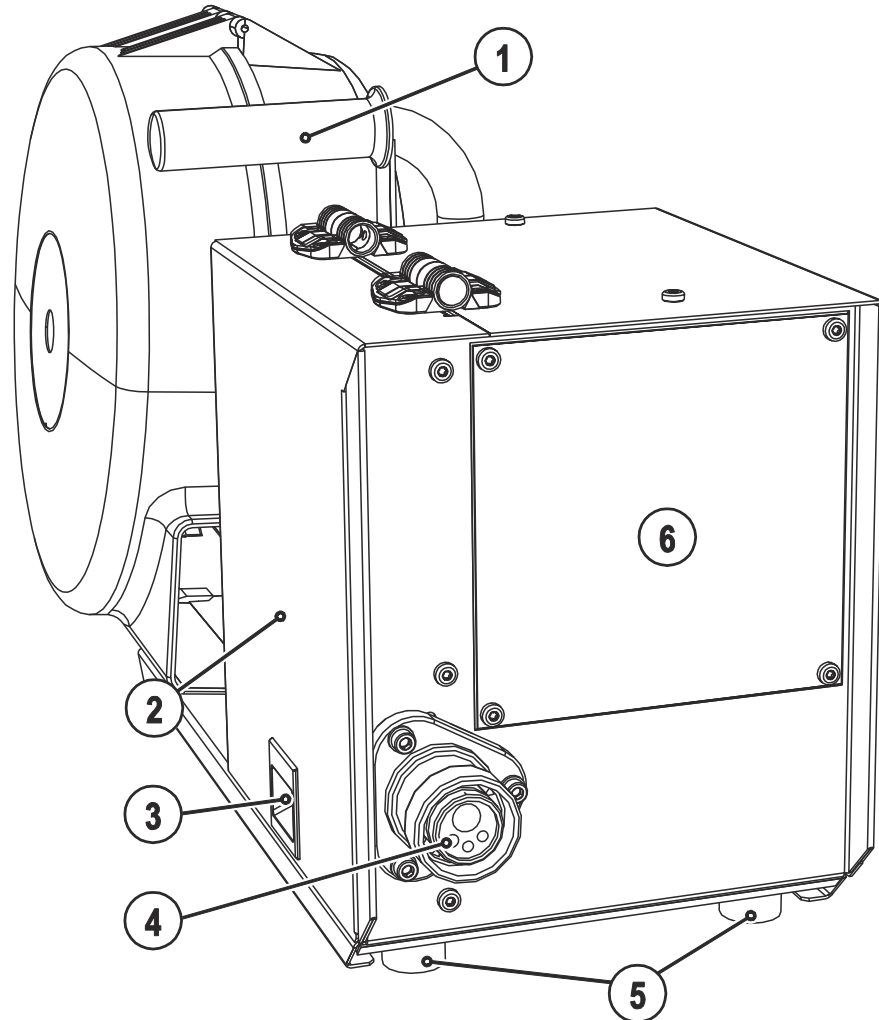

Figure 4-1

Item	Symbol	Description
1		Carrying handle
2		Protective cap Cover for the wire feed mechanism and other operating elements. Depending on the machine series, additional stickers with information on the replacement parts will be located on the inside.
3		Slide latch, lock for the protective cap
4		Welding torch connection (Euro torch connector) Welding current, shielding gas and torch trigger integrated
5		Machine feet
6		Machine control See Machine control – operating elements chapter

4.2 Rear view

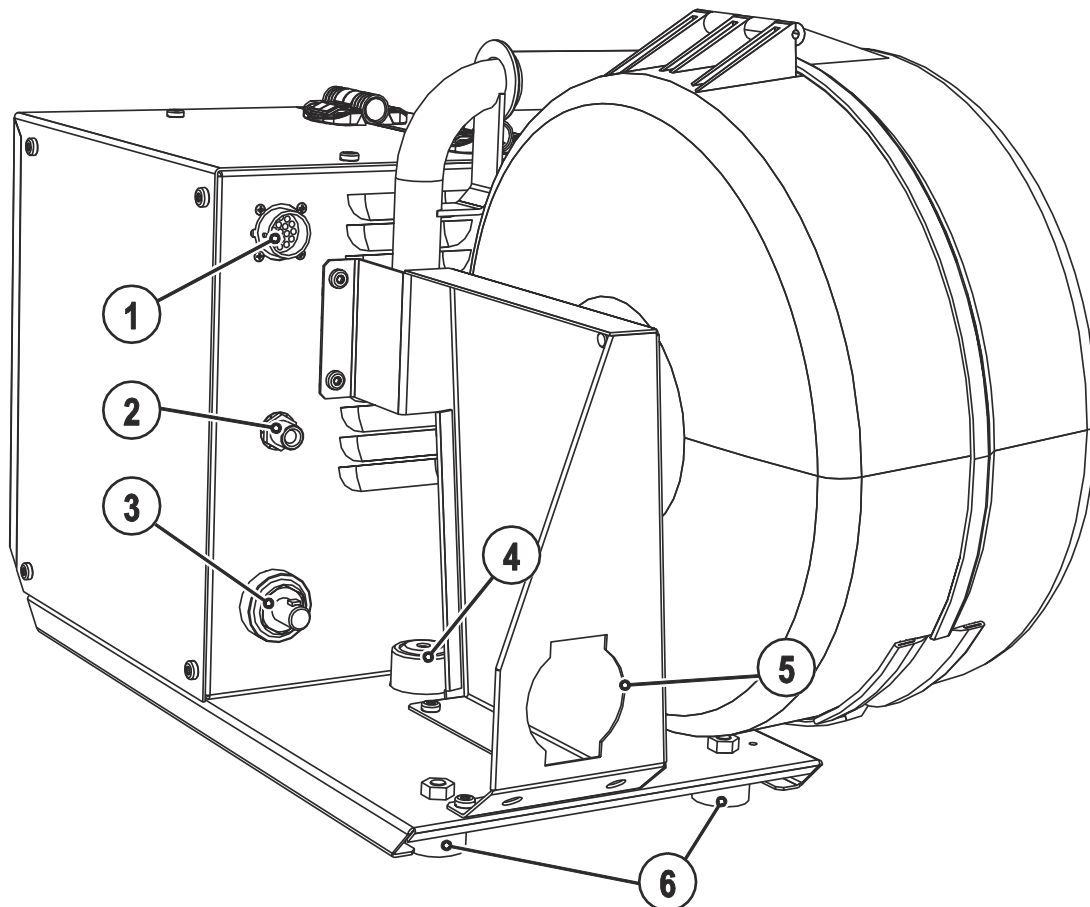

Figure 4-2

Item	Symbol	Description
1		19-pole connection socket (analogue) Wire feed unit control lead connection
2		Connecting nipple G$\frac{1}{4}$, shielding gas connection
3		Connector plug, welding current "+" Welding current connection on wire feed unit
4		Take up point For housing arbor, wire feed unit
5		Intermediate hose package strain relief
6		Machine feet

4.3 Inside view

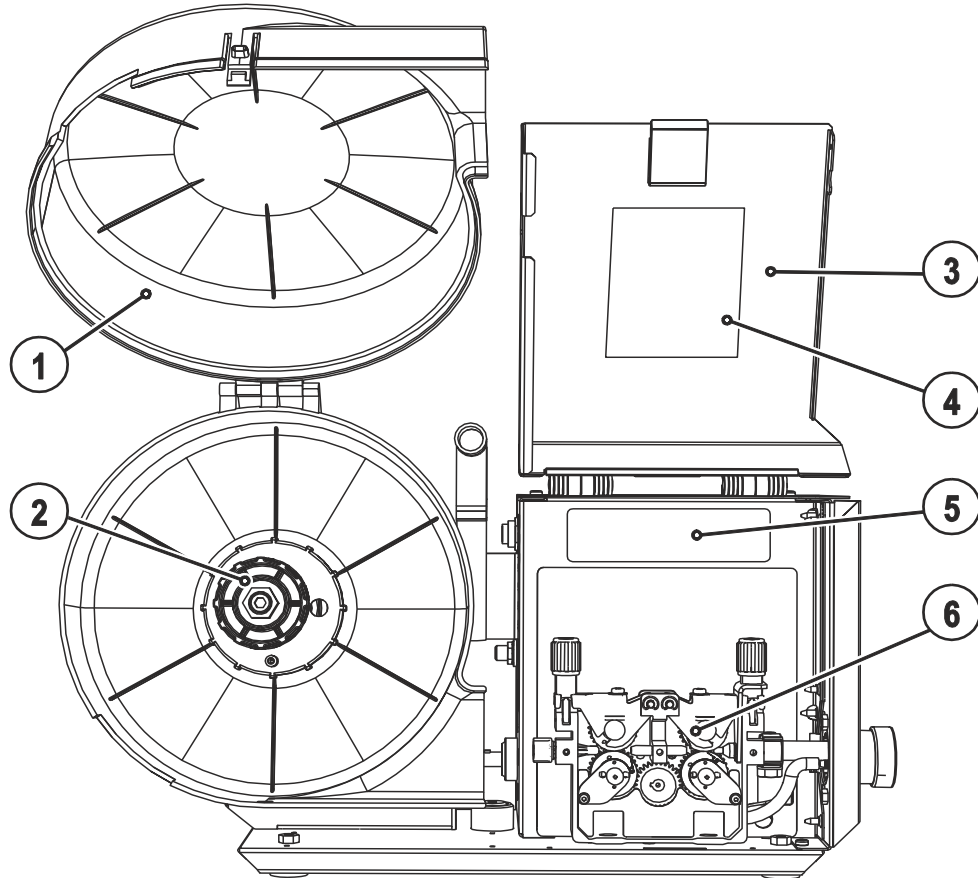

Figure 4-3

Item	Symbol	Description
1		Cover of the wire spool
2		Wire spool holder
3		Protective cap Cover for the wire feed mechanism and other operating elements. Depending on the machine series, additional stickers with information on the replacement parts will be located on the inside.
4		Label, Wire feed parts subject to wear
5		Operating elements (see chapter Internal operating elements)
6		Wire feed unit

4.3.1 Internal operating elements

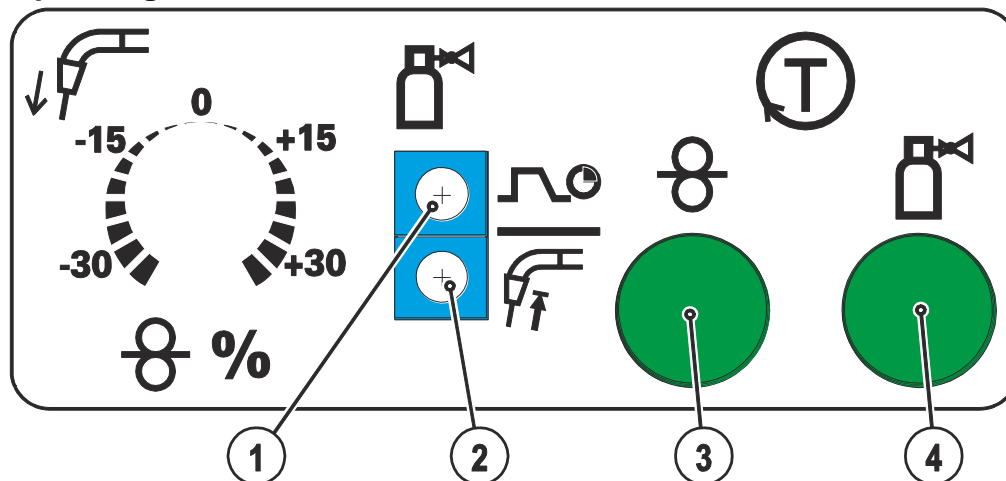

Figure 4-4

All details in percent relate to the values stored in the characteristics.

Item	Symbol	Description
1		"Gas post-flow time" trimmer Setting range 0.2-10 s
2		Trimmer, Burn-back +/- 50%
3		Key Button, Wire inching Currentless wire inching
4		Key button, Gas test Currentless gas test

4.4 Machine control – Operating elements

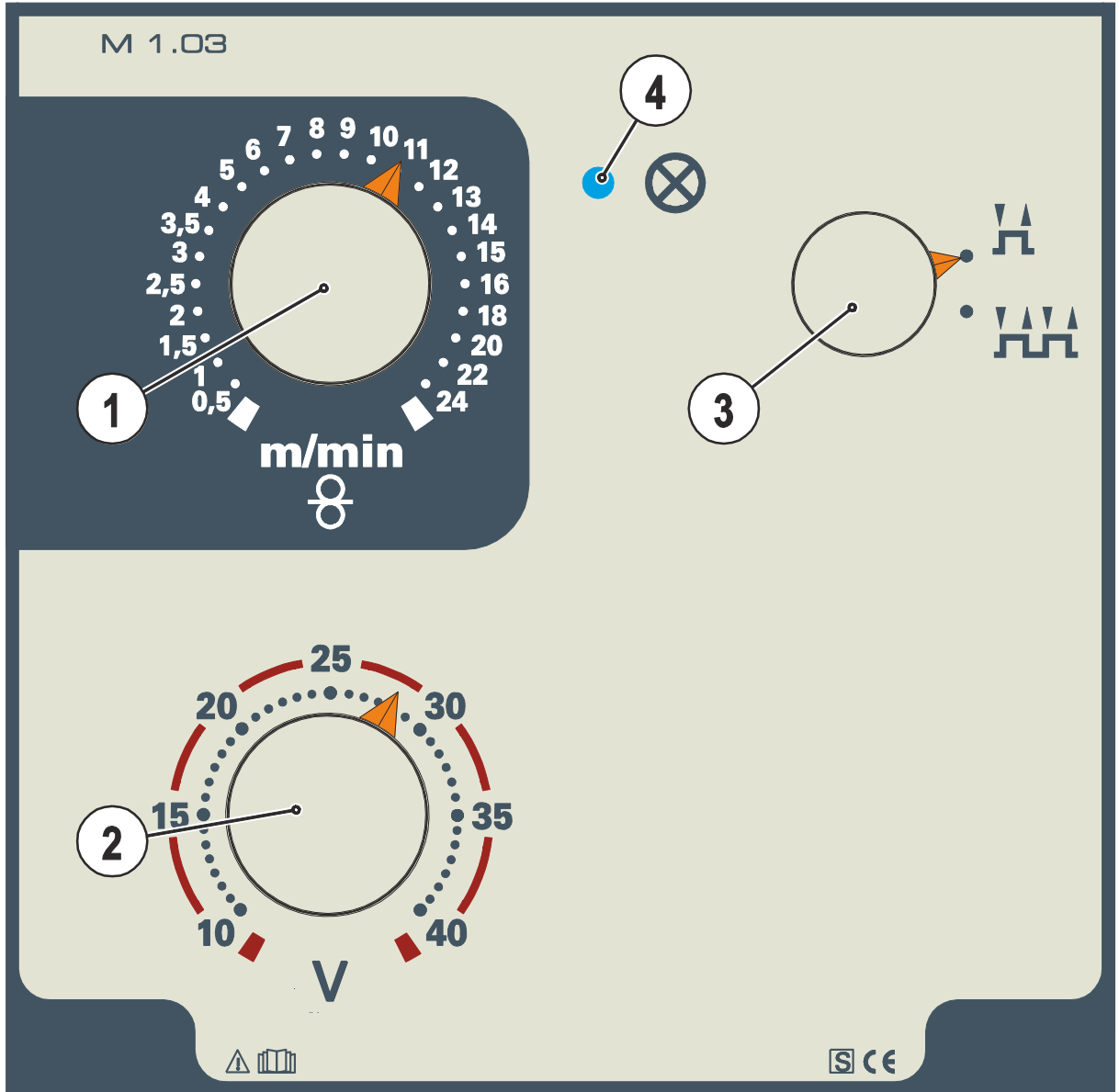





Figure 4-5

Item	Symbol	Description
1		Rotary dial, Wire speed setting Infinite adjustment of the wire speed.
2		Rotary dial, welding voltage Adjustment of the welding voltage from min. to max.
3		"Operating mode" selector switch Changeover between non-latched or latched.
4		Ready for operation signal light Signal light on when the machine is switched on and ready for operation

4.4.1 Setting the operating point (welding output)

This control works according to the twin-knob operation principle. To set the operating point, only the wire speed and the welding voltage need to be set according to the material and the electrode diameter.

Operating element	Action	Result
 <p>A circular knob with a scale from 0 to 24 m/min. The needle points to approximately 12.</p>		Wire speed setting
 <p>A circular knob with a scale from 0 to 40 V. The needle points to approximately 25.</p>		Welding voltage setting

5 Design and function

5.1 General

WARNING



Risk of injury from electric shock!

Contact with live parts, e.g. welding current sockets, is potentially fatal!

- Follow safety instructions on the opening pages of the operating instructions.
- Commissioning may only be carried out by persons who have the relevant expertise of working with arc welding machines!
- Connection and welding leads (e.g. electrode holder, welding torch, workpiece lead, interfaces) may only be connected when the machine is switched off!

CAUTION



Insulate the arc welder from welding voltage!

Not all active parts of the welding current circuit can be shielded from direct contact. To avoid any associated risks it is vital for the welder to adhere to the relevant safety regulations. Even low voltages can cause a shock and lead to accidents.

- Wear dry and undamaged protective clothing (shoes with rubber soles/welder's gloves made from leather without any studs or braces)!
- Avoid direct contact with non-insulated connection sockets or connectors!
- Always place torches and electrode holders on an insulated surface!



Risk of burns on the welding current connection!

If the welding current connections are not locked, connections and leads heat up and can cause burns, if touched!

- Check the welding current connections every day and lock by turning in clockwise direction, if necessary.



Risk of injury due to moving parts!

The wire feeders are equipped with moving parts, which can trap hands, hair, clothing or tools and thus injure persons!

- Do not reach into rotating or moving parts or drive components!
- Keep casing covers or protective caps closed during operation!



Risk of injury due to welding wire escaping in an unpredictable manner!

Welding wire can be conveyed at very high speeds and, if conveyed incorrectly, may escape in an uncontrolled manner and injure persons!

- Before mains connection, set up the complete wire guide system from the wire spool to the welding torch!
- Remove the pressure rollers from the wire feeder if no welding torch is fitted!
- Check wire guide at regular intervals!
- Keep all casing covers or protective caps closed during operation!



Risk from electrical current!

If welding is carried out alternately using different methods and if a welding torch and an electrode holder remain connected to the machine, the open-circuit/welding voltage is applied simultaneously on all cables.

- The torch and the electrode holder should therefore always be placed on an insulated surface before starting work and during breaks.

CAUTION



Damage due to incorrect connection!

Accessory components and the power source itself can be damaged by incorrect connection!

- Only insert and lock accessory components into the relevant connection socket when the machine is switched off.
- Comprehensive descriptions can be found in the operating instructions for the relevant accessory components.
- Accessory components are detected automatically after the power source is switched on.



Using protective dust caps!

Protective dust caps protect the connection sockets and therefore the machine against dirt and damage.

- The protective dust cap must be fitted if there is no accessory component being operated on that connection.
- The cap must be replaced if faulty or if lost!

NOTE



Observe documentation of other system components when connecting!

5.2 Transport and installation

WARNING



Risk of accident due to improper transport of machines that may not be lifted!

Do not lift or suspend the machine! The machine can fall down and cause injuries! The handles and brackets are suitable for transport by hand only!

- The machine may not be lifted by crane or suspended!
- Depending on machine type, equipment for lifting by crane or use while suspended is available as a retrofitting option (see chapter "Accessories").

CAUTION



Installation site!

The machine must not be operated in the open air and must only be set up and operated on a suitable, stable and level base!

- The operator must ensure that the ground is non-slip and level, and provide sufficient lighting for the place of work.
- Safe operation of the machine must be guaranteed at all times.

5.3 Notes on the installation of welding current leads

NOTE

- Incorrectly installed welding current leads can cause faults in the arc (flickering).
- A** Install welding lead and hose package in parallel and as close together as possible.
- B** Keep the welding lead and hose packages of each welding machine separate, with an installation distance of at least 15 cm!
- C** Fully unroll welding current leads, torch hose packages and intermediate hose packages. Avoid loops!
- D** Use an individual welding lead to the workpiece for each welding machine!
Connect the work clamp close to the welding point.
- E** Always keep leads as short as possible!

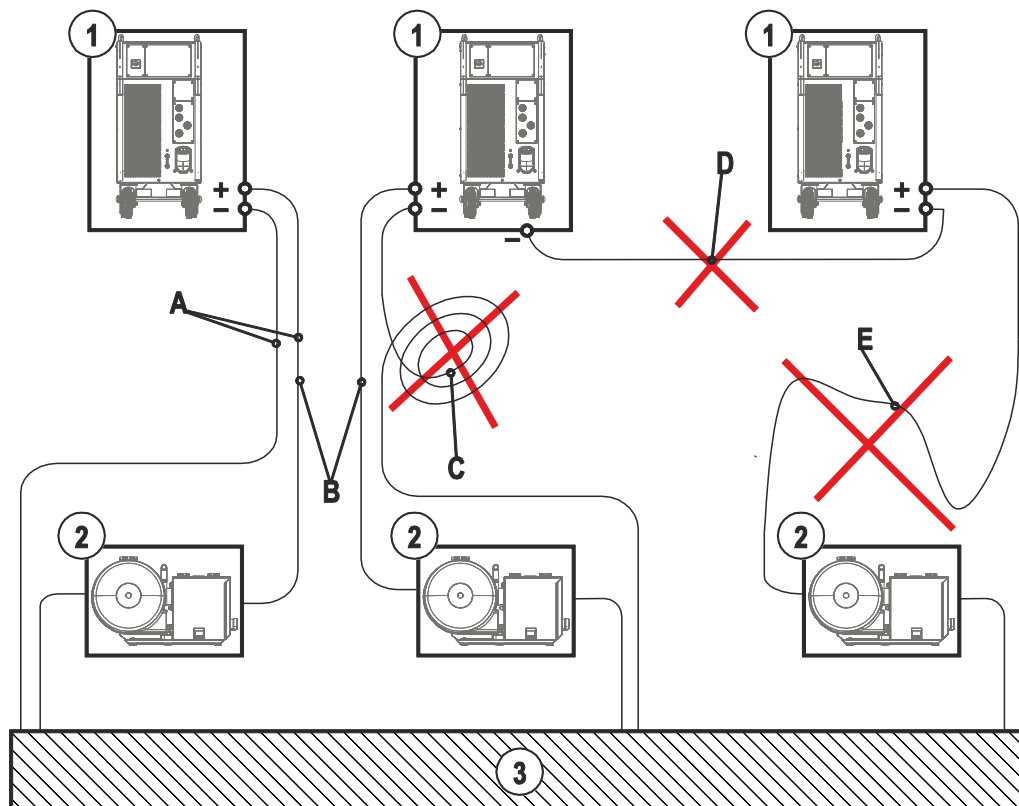



Figure 5-1

Item	Symbol	Description
1		Welding machine
2		Wire feed unit
3		Workpiece

5.4 Shielding gas supply (shielding gas cylinder for welding machine)

5.4.1 Gas test

- Slowly open the gas cylinder valve.
- Open the pressure regulator.
- Switch on the power source at the main switch.
- Trigger gas test function on the machine control inside the machine.
- Set the relevant gas quantity for the application on the pressure regulator.
- The gas test is triggered at the machine control inside the machine by pressing the  key.

The shielding gas will flow as long as you keep the button pressed.

5.4.2 Setting the shielding gas quantity

Welding process	Recommended shielding gas quantity
MAG welding	Wire diameter x 11.5 = l/min
MIG brazing	Wire diameter x 11.5 = l/min
MIG welding (aluminium)	Wire diameter x 13.5 = l/min (100 % argon)

Helium-rich gas mixtures require a higher gas volume!

The table below can be used to correct the gas volume calculated where necessary:

Shielding gas	Factor
75% Ar/25% He	1.14
50% Ar/50% He	1.35
25% Ar/75% He	1.75
100% He	3.16

NOTE



Incorrect shielding gas setting!

If the shielding gas setting is too low or too high, this can introduce air to the weld pool and may cause pores to form.

- Adjust the shielding gas quantity to suit the welding task!

5.5 Intermediate hose package connection

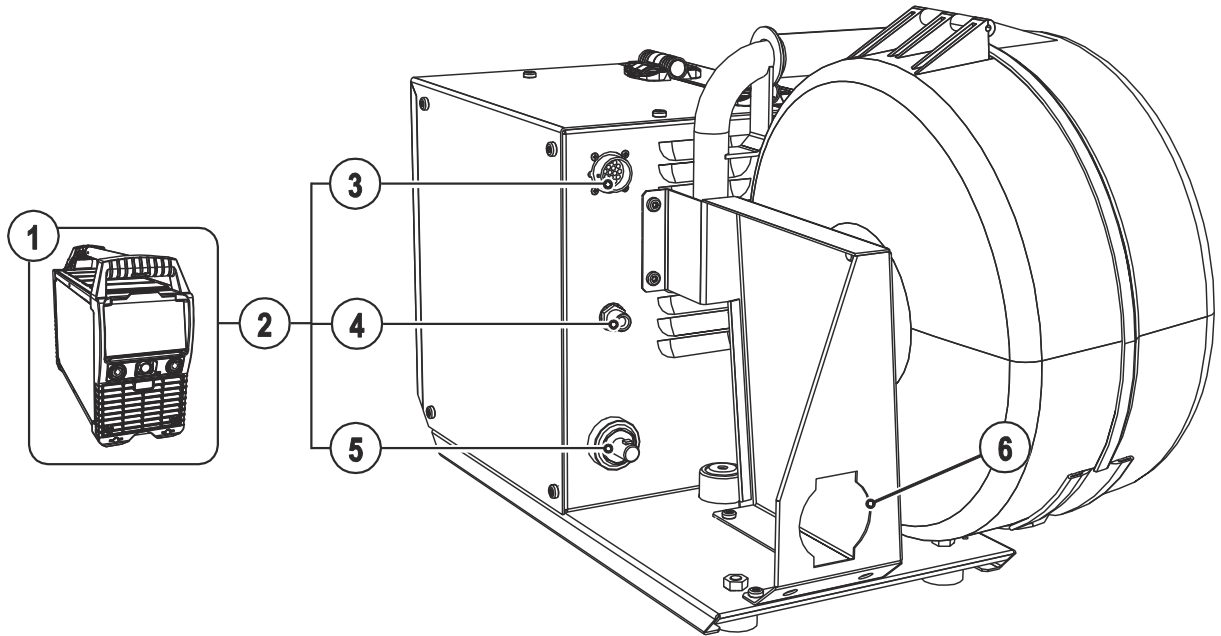

Figure 5-2

Item	Symbol	Description
1		Power source
2		Intermediate hose package
3		19-pole connection socket (analogue) Wire feed unit control lead connection
4		Connecting nipple G$\frac{1}{4}$, shielding gas connection
5		Connector plug, welding current "+" Welding current connection on wire feed unit
6		Intermediate hose package strain relief

- Insert the end of the hose package through the strain relief of the hose package and lock by turning to the right.
- Insert the plug on the welding current lead into the welding current connection socket "+" and lock.
- Connect crown nut of the shielding gas line to the G $\frac{1}{4}$ " connecting nipple.
- Insert cable plug on the control lead into the 19-pole connection socket and secure with crown nut (the plug can only be inserted into the connection socket in one position).

5.6 Welding torch connection

NOTE



Fault with the wire guide!

On delivery, the central connector is fitted with a capillary tube for welding torches with spiral guides. Conversion is necessary if a welding torch with a plastic core is used!

Welding torch with plastic core:

- use with guide tube!

Welding torch with spiral guide:

- use with capillary tube!

Preparation for connecting welding torches with a plastic core:

- Push forward the capillary tube on the wire feed side in the direction of the central connector and remove it there.
- Slide plastic core guide tube off the central connector.
- Carefully insert the central plug for the welding torch, with the still oversized plastic liner, into the central connector and screw together with crown nut.
- Use a suitable tool to cut off the plastic liner just before the wire feed roller, making sure not to pinch it.
- Unfasten and remove the central plug on the welding torch.
- Cleanly remove the burr from the separated end of the plastic core!

Preparation for connecting welding torches with a spiral guide:

- Check that the capillary tube is correctly positioned in relation to the central connector!

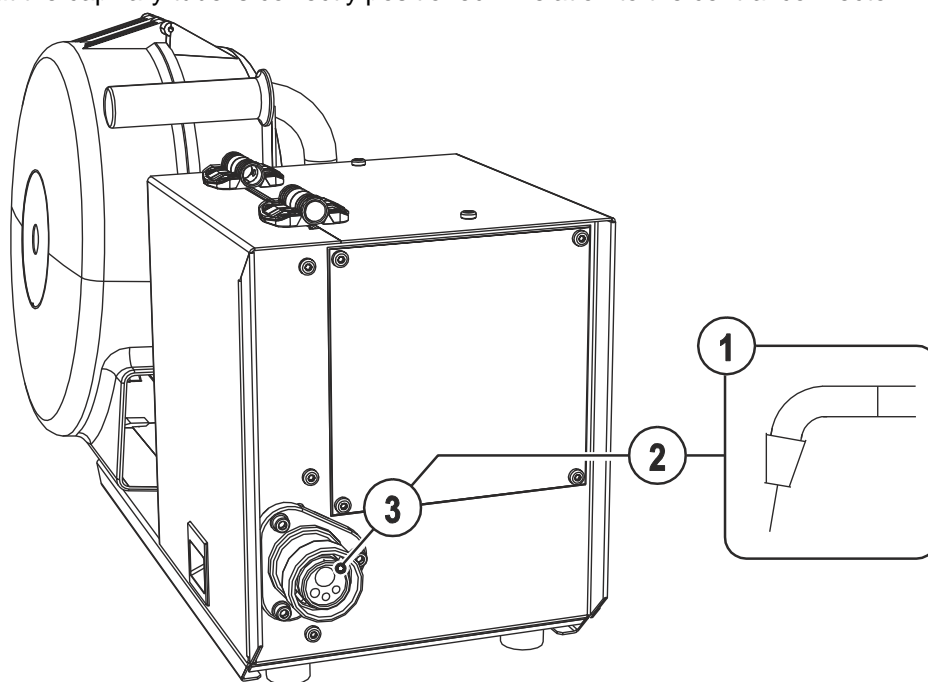

Figure 5-3

Item	Symbol	Description
1		Welding torch
2		Welding torch hose package
3		Welding torch connection (Euro torch connector) Welding current, shielding gas and torch trigger integrated

- Insert the central plug for the welding torch into the central connector and screw together with crown nut.

5.7 Wire feed

5.7.1 Open the protective flap of the wire feeder

CAUTION



To perform the following steps, the protective flap of the wire feeder needs to be opened. Make sure to close the protective flap again before starting to work.

- Unlock and open protective flap.

5.7.2 Inserting the wire spool

CAUTION



Risk of injury due to incorrectly secured wire spool.

If the wire spool is not secured properly, it may come loose from the wire spool holder and fall to the ground, causing damage to the machine and injuries.

- Securely fasten the wire spool to the wire spool holder using the knurled nut.
- Before you start working, always check the wire spool is securely fastened.

NOTE



Standard D300 wire spool holder can be used. Adapters (see accessories) are required when using standardised basket coils (DIN 8559).

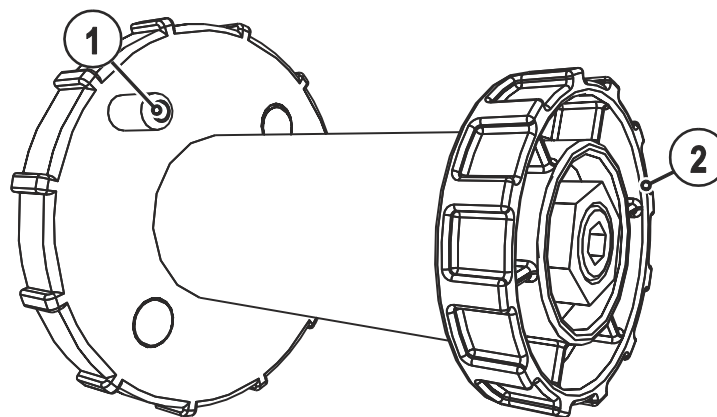

Figure 5-4

Item	Symbol	Description
1		Carrier pin For fixing the wire spool
2		Knurled nut For fixing the wire spool

- Loosen knurled nut from spool holder.
- Fix welding wire reel onto the spool holder so that the carrier pin locks into the spool bore.
- Fasten wire spool using knurled nut.

5.7.3 Changing the wire feed rollers

NOTE



Unsatisfactory welding results due to faulty wire feeding!

Wire feed rollers must be suitable for the diameter of the wire and the material.

- Check the roller label to verify that the rollers are suitable for the wire diameter. Turn or change if necessary!
- use V-groove rollers with for steel wires and other hard wires,
- use U-groove rollers for aluminium wires and other soft, alloyed wires.

- Slide new drive rollers into place so that the diameter of the wire used is visible on the drive roller.
- Screw the drive rollers in place with knurled screws.

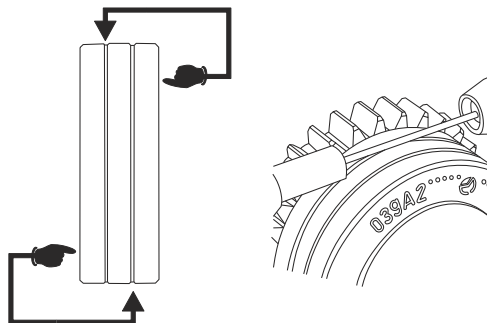

Figure 5-5

5.7.4 Inching the wire electrode

 CAUTION**Risk of injury due to moving parts!**

The wire feeders are equipped with moving parts, which can trap hands, hair, clothing or tools and thus injure persons!

- Do not reach into rotating or moving parts or drive components!
- Keep casing covers or protective caps closed during operation!

**Risk of injury due to welding wire escaping in an unpredictable manner!**

Welding wire can be conveyed at very high speeds and, if conveyed incorrectly, may escape in an uncontrolled manner and injure persons!

- Before mains connection, set up the complete wire guide system from the wire spool to the welding torch!
- Remove the pressure rollers from the wire feeder if no welding torch is fitted!
- Check wire guide at regular intervals!
- Keep all casing covers or protective caps closed during operation!

**Risk of injury due to welding wire escaping from the welding torch!**

The welding wire can escape from the welding torch at high speed and cause bodily injury including injuries to the face and eyes!

- Never direct the welding torch towards your own body or towards other persons!

CAUTION

**Extensive wear due to incorrect contact pressure!**

Incorrect contact pressure will cause extensive wear of the wire feed rollers!

- With the adjusting nuts of the pressure units set the contact pressure so that the wire electrode is conveyed but will still slip through if the wire spool jams.
- Set the contact pressure of the front rollers (in wire feed direction) to a higher value!

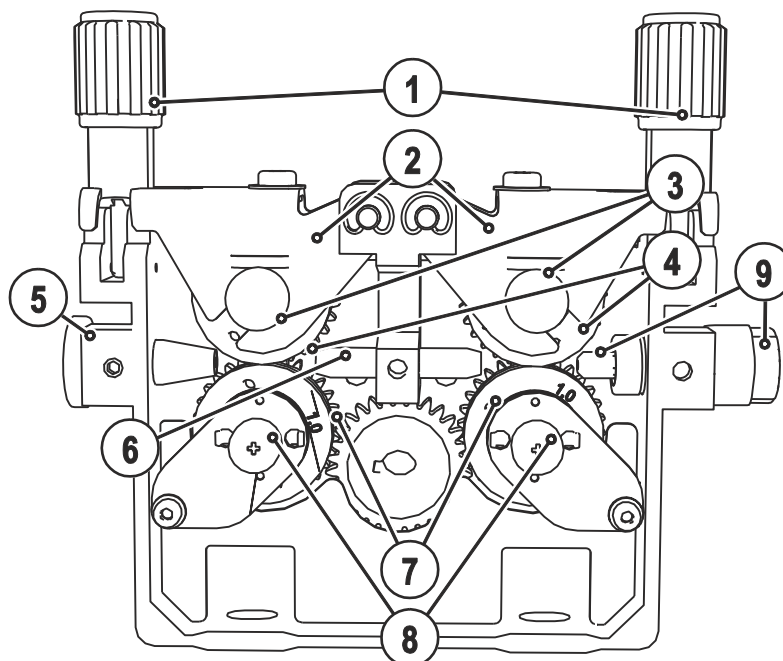

Figure 5-6

Item	Symbol	Description
1		Pressure unit
2		Clamping unit
3		Knurled nut
4		Pressure roller
5		Wire feed nipple
6		Guide tube
7		Drive rollers
8		"Undetachable" knurled screws
9		Wire feed nipple with wire stabiliser

- Extend and lay out the torch hose package.
- Unfasten pressure units and fold out (clamping units and pressure rollers will automatically flip upwards).
- Unwind welding wire carefully from the wire spool and insert through the wire inlet nipple over the drive roller grooves and the guide pipe into the capillary tube and Teflon core using guide pipe.
- Press the clamping element with the pressure roller back downwards and fold the wire units back up again (wire electrode should be in the groove on the drive roller).
- Set the contact pressure with the adjusting nuts of the pressure unit.
- Press the wire inching button until the wire electrode projects out of the welding torch.

5.7.5 Spool brake setting

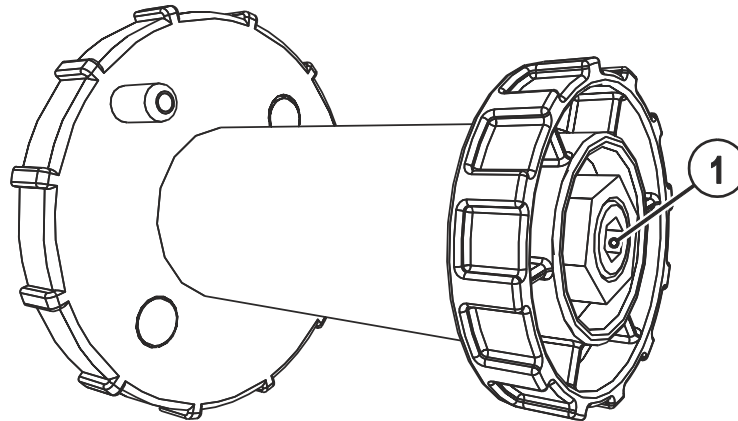

Figure 5-7

Item	Symbol	Description
1		Allen screw Securing the wire spool retainer and adjustment of the spool brake

- Tighten the Allen screw (8 mm) in the clockwise direction to increase the braking effect.

NOTE













Tighten the spool brake until the wire spool no longer turns when the wire feed motor stops but without it jamming during operation!

5.8 MIG/MAG functional sequences / operating modes

NOTE

 There are optimum pre-sets for welding parameters such as gas pre-flow and burn back, etc. for numerous applications (although these can also be changed if required).

5.8.1 Explanation of signs and functions

Symbol	Meaning
	Press torch trigger
	Release torch trigger
	Tap torch trigger (press briefly and release)
	Shielding gas flowing
I	Welding output
	Wire electrode is being conveyed
	Wire creep
	Wire burn-back
	Gas pre-flows
	Gas post-flows
	Non-latched
	Latched
t	Time

5.8.2 Non-latched mode

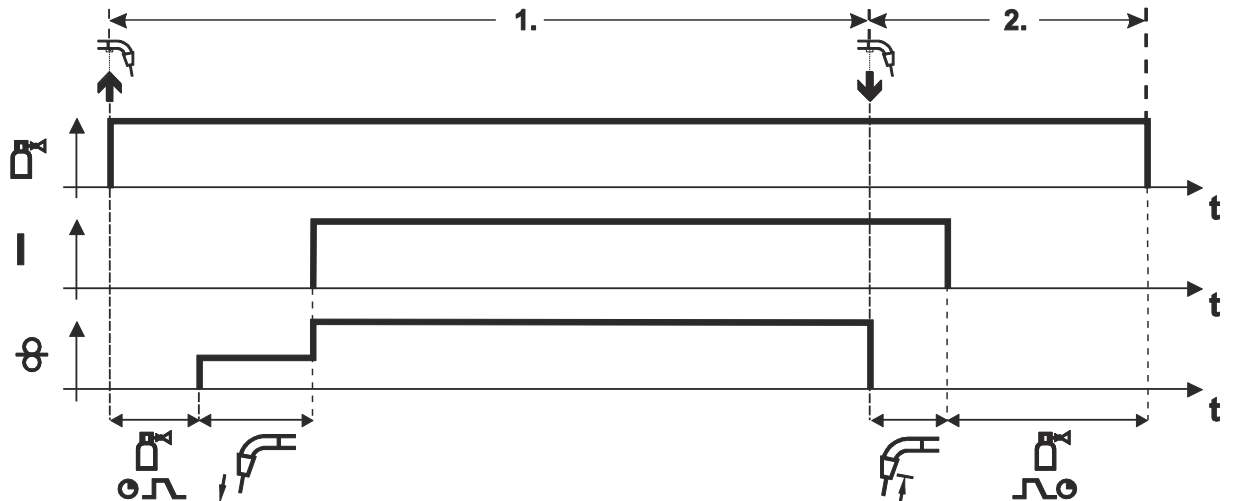

Figure 5-8

Step 1

- Press and hold torch trigger.
- Shielding gas is expelled (gas pre-flows).
- Arc ignites after the wire electrode makes contact with the workpiece; welding current flows.
- Changeover to the pre-selected wire speed.

Step 2

- Release torch trigger.
- WF motor stops.
- Arc is extinguished after the pre-selected wire burn-back time elapses.
- Gas post-flow time elapses.

5.8.3 Latched mode

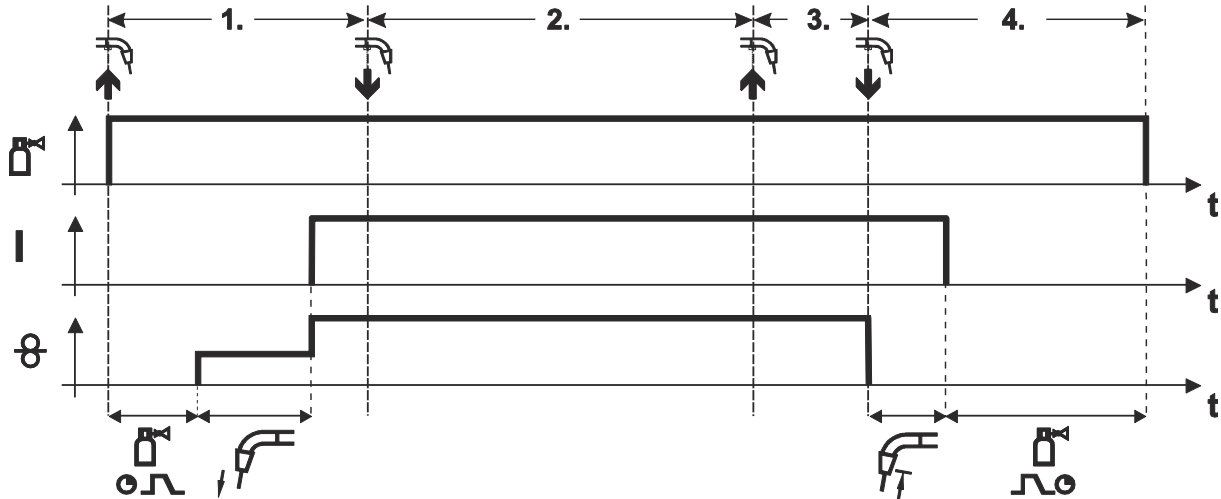

Figure 5-9

Step 1

- Press and hold torch trigger.
- Shielding gas is expelled (gas pre-flows).
- Arc ignites when the wire electrode makes contact with the workpiece; welding current flows.
- Changeover to the pre-selected wire speed.

Step 2

- Release torch trigger (no effect).

Step 3

- Press torch trigger (no effect).

Step 4

- Release torch trigger.
- WF motor stops.
- Arc is extinguished after the pre-selected wire burn-back time elapses.
- Gas post-flow time elapses.

5.8.4 MIG/MAG automatic cut-out

NOTE

- The welding machine ends the ignition process or the welding process with an
 - Ignition fault (no welding current flows within 5 s after the start signal).
 - Arc interruption (arc is interrupted for longer than 2 s).

6 Maintenance, care and disposal



DANGER



Risk of injury from electric shock!

Cleaning machines that are not disconnected from the mains can lead to serious injuries!

- Disconnect the machine completely from the mains.
- Remove the mains plug!
- Wait for 4 minutes until the capacitors have discharged!

6.1 General

When used in the specified environmental conditions and under normal operating conditions, this machine is largely maintenance-free and requires a minimum of care.

There are some points, which should be observed, to guarantee fault-free operation of your welding machine. Among these are regular cleaning and checking as described below, depending on the pollution level of the environment and the length of time the unit is in use.

6.2 Maintenance work, intervals

CAUTION



Electric current!

Repairs may only be carried out by authorised specialist staff!

- Do not remove the torch from the hose package!
- Never clamp the torch body in a vice or similar, as this can cause the torch to be irreparably destroyed!
- If damage occurs to the torch or to the hose package which cannot be corrected as part of the maintenance work, the entire torch must be returned to the manufacturer

6.2.1 Daily maintenance tasks

- Check that all connections and wearing parts are hand-tight and tighten if necessary.
- Check that all screw and plug connections and replaceable parts are secured correctly, tighten if necessary.
- Remove any spatter.
- Clean the wire feed rollers on a regular basis (depending on the degree of soiling).

6.2.1.1 Visual inspection

- Check hose package and power connections for exterior damage and replace or have repaired by specialist staff as necessary!
- Mains supply lead and its strain relief
- Gas tubes and their switching equipment (solenoid valve)
- Other, general condition

6.2.1.2 Functional test

- Check correct mounting of the wire spool.
- Welding current cables (check that they are fitted correctly and secured)
- Gas cylinder securing elements
- Operating, message, safety and adjustment devices (Functional test)

6.2.2 Monthly maintenance tasks

6.2.2.1 Visual inspection

- Casing damage (front, rear and side walls)
- Wheels and their securing elements
- Transport elements (strap, lifting lugs, handle)

6.2.2.2 Functional test

- Selector switches, command devices, emergency stop devices, voltage reducing devices, message and control lamps
- Check that the wire guide elements (inlet nipple, wire guide tube) are fitted securely.

6.2.3 Annual test (inspection and testing during operation)

NOTE



The welding machine may only be tested by competent, capable persons!

A capable person is one who, because of his training, knowledge and experience, is able to recognise the dangers that can occur while testing welding power sources as well as possible subsequent damage and who is able to implement the required safety procedures.



For further information, please see the accompanying supplementary sheets "Machine and Company Data, Maintenance and Testing, Warranty"!

A periodic test according to IEC 60974-4 "Periodic inspection and test" has to be carried out. In addition to the regulations on testing given here, the relevant local laws and regulations must also be observed.

6.3 Maintenance work



DANGER



Do not carry out any unauthorised repairs or modifications!

To avoid injury and equipment damage, the unit must only be repaired or modified by specialist, skilled persons!

The warranty becomes null and void in the event of unauthorised interference.

- Appoint only skilled persons for repair work (trained service personnel)!

Repair and maintenance work may only be performed by qualified authorised personnel; otherwise the right to claim under warranty is void. In all service matters, always consult the dealer who supplied the machine. Return deliveries of defective equipment subject to warranty may only be made through your dealer. When replacing parts, use only original spare parts. When ordering spare parts, please quote the machine type, serial number and item number of the machine, as well as the type designation and item number of the spare part.

6.4 Disposing of equipment

NOTE



Proper disposal!

The machine contains valuable raw materials, which should be recycled, and electronic components, which must be disposed of.

- Do not dispose of in household waste!
- Observe the local regulations regarding disposal!



6.4.1 Manufacturer's declaration to the end user

- According to European provisions (guideline 2002/96/EG of the European Parliament and the Council of January, 27th 2003), used electric and electronic equipment may no longer be placed in unsorted municipal waste. It must be collected separately. The symbol depicting a waste container on wheels indicates that the equipment must be collected separately. This machine is to be placed for disposal or recycling in the waste separation systems provided for this purpose.
- According to German law (law governing the distribution, taking back and environmentally correct disposal of electric and electronic equipment (ElektroG) from 16.03.2005), used machines are to be placed in a collection system separate from unsorted municipal waste. The public waste management utilities (communities) have created collection points at which used equipment from private households can be disposed of free of charge.
- Information about giving back used equipment or about collections can be obtained from the respective municipal administration office.
- EWM participates in an approved waste disposal and recycling system and is registered in the Used Electrical Equipment Register (EAR) under number WEEE DE 57686922.
- In addition to this, returns are also possible throughout Europe via EWM sales partners.

6.5 Meeting the requirements of RoHS

We, EWM AG Mündersbach, hereby confirm that all products supplied by us which are affected by the RoHS Directive, meet the requirements of the RoHS (Directive 2002/95/EC).

7 Rectifying faults

All products are subject to rigorous production checks and final checks. If, despite this, something fails to work at any time, please check the product using the following flowchart. If none of the fault rectification procedures described leads to the correct functioning of the product, please inform your authorised dealer.

7.1 Checklist for rectifying faults

NOTE



The correct machine equipment for the material and process gas in use is a fundamental requirement for perfect operation!

Legend	Symbol	Description
	↘	Fault/Cause
	✘	Remedy

Wire feed problems

- ↘ Contact tip blocked
 - ✘ Clean, spray with anti-spatter spray and replace if necessary
- ↘ Setting the spool brake (see "Setting the spool brake" chapter)
 - ✘ Check settings and correct if necessary
- ↘ Setting pressure units (see "Inching wire electrodes" chapter)
 - ✘ Check settings and correct if necessary
- ↘ Worn wire rolls
 - ✘ Check and replace if necessary
- ↘ Wire feed motor without supply voltage (automatic cutout triggered by overloading)
 - ✘ Reset triggered fuse (rear of the power source) by pressing the key button
- ↘ Kinked hose packages
 - ✘ Extend and lay out the torch hose package
- ↘ Wire guide core or spiral is dirty or worn
 - ✘ Clean core or spiral; replace kinked or worn cores

Functional errors

- ↘ Machine control without displaying the signal lights after switching on
 - ✘ Phase failure > check mains connection (fuses)
- ↘ No welding performance
 - ✘ Phase failure > check mains connection (fuses)
- ↘ Connection problems
 - ✘ Make control lead connections and check that they are fitted correctly.
- ↘ Loose welding current connections
 - ✘ Tighten power connections on the torch and/or on the workpiece
 - ✘ Tighten contact tip correctly

8 Technical data

NOTE

 Performance specifications and guarantee only in connection with original spare and replacement parts!

Supply voltage	42 VAC
Max. welding current at 60 % DC	550 A
Max. welding current at 100 % DC	420 A
Wire feed speed	0.5 m/min to 24 m/min
Standard roller fitting	1.0 and 1.2 mm (for steel wire)
Drive type	4-roller (37 mm)
Torch connection	Euro central connection
Protection classification	IP23
Ambient temperature	-25 °C to +40 °C
Dimensions L x W x H in mm	690 x 300 x 410
Weight	13 kg
EMC class	A
Constructed to standards	IEC 60974-1, -5, -10 CE

9 Accessories

NOTE



Performance-dependent accessories like torches, workpiece leads, electrode holders or intermediate hose packages are available from your authorised dealer.

9.1 General accessories

Type	Designation	Item no.
AK300	Wire spool adapter K300	094-001803-00001
DM AR/MIX 35L/MIN	Manometer pressure regulator	094-000009-00000
GH 2X1/4" 2M	Gas hose	094-000010-00001

9.2 Options

Type	Designation	Item no.
ON CMF drive 4L	Optional retrofit crane suspension for drive 4L	092-002483-00000
ON WAKD2 4L/41L	Optional wheel assembly retrofit kit for drive 4L	090-008151-00000
ON WAKD 4L/41L	Wheel assembly kit for DRIVE 4L	090-008169-00000
ON PS drive 4L T/P	Pivot support	092-002112-00000

10 Replaceable parts

CAUTION



Damage due to the use of non-genuine parts!

The manufacturer's warranty becomes void if non-genuine parts are used!

- Only use system components and options (power sources, welding torches, electrode holders, remote controls, spare parts and replacement parts, etc.) from our range of products!
- Only insert and lock accessory components into the relevant connection socket when the machine is switched off.

10.1 Wire feed rollers

10.1.1 Wire feed rollers for steel wire

Type	Designation	Item no.
FE 2DR4R 0,6+0,8	Drive rollers, 37 mm, steel	092-000839-00000
FE 2DR4R 0,8+1,0	Drive rollers, 37 mm, steel	092-000840-00000
FE 2DR4R 0,9+1,2	Drive rollers, 37 mm, steel	092-000841-00000
FE 2DR4R 1,0+1,2	Drive rollers, 37 mm, steel	092-000842-00000
FE 2DR4R 1,2+1,6	Drive rollers, 37 mm, steel	092-000843-00000
FE/AL 2GR4R	Pressure rollers, smooth, 37mm	092-000844-00000

10.1.2 Wire feed rollers for aluminium wire

Type	Designation	Item no.
AL 4ZR4R 0,8+1,0	Twin rollers, 37 mm, for aluminium	092-000869-00000
AL 4ZR4R 1,0+1,2	Twin rollers, 37 mm, for aluminium	092-000848-00000
AL 4ZR4R 1,2+1,6	Twin rollers, 37 mm, for aluminium	092-000849-00000
AL 4ZR4R 2,4+3,2	Twin rollers, 37 mm, for aluminium	092-000870-00000

10.1.3 Wire feed rollers for cored wire

Type	Designation	Item no.
ROE 2DR4R 0,8/0,9+0,8/0,9	Drive rollers, 37 mm, cored wire	092-000834-00000
ROE 2DR4R 1,0/1,2+1,4/1,6	Drive rollers, 37 mm, cored wire	092-000835-00000
ROE 2DR4R 1,4/1,6+2,0/2,4	Drive rollers, 37 mm, cored wire	092-000836-00000
ROE 2DR4R 2,8+3,2	Drive rollers, 37 mm, cored wire	092-000837-00000
ROE 2GR4R	Pressure rollers, knurled, 37mm	092-000838-00000

10.1.4 Conversion sets

Type	Designation	Item no.
URUE VERZ>UNVERZ FE/AL 4R	Conversion kit, 37mm, 4-roller drive on non-toothed rollers (steel/aluminium)	092-000845-00000
URUE AL 4ZR4R 0,8+1,0	Conversion kit, 37mm, 4-roller drive for aluminium	092-000867-00000
URUE AL 4ZR4R 1,0+1,2	Conversion kit, 37mm, 4-roller drive for aluminium	092-000846-00000
URUE AL 4ZR4R 1,2+1,6	Conversion kit, 37mm, 4-roller drive for aluminium	092-000847-00000
URUE AL 4ZR4R 2,4+3,2	Conversion kit, 37mm, 4-roller drive for aluminium	092-000868-00000
URUE ROE 2DR4R 0,8/0,9+0,8/0,9	Conversion kit, 37mm, 4-roller drive for cored wire	092-000830-00000
URUE ROE 2DR4R 1,0/1,2+1,4/1,6	Conversion kit, 37mm, 4-roller drive for cored wire	092-000831-00000
URUE ROE 2DR4R 1,4/1,6+2,0/2,4	Conversion kit, 37mm, 4-roller drive for cored wire	092-000832-00000
URUE ROE 2DR4R 2,8+3,2	Conversion kit, 37mm, 4-roller drive for cored wire	092-000833-00000

Verschleißteile 4 Rollen-Antrieb Ø = 37mm		St= Stahl Al= Aluminium CrNi= Edelstahl Cu= Kupfer		St= Steel Al= Aluminium CrNi= Stainless steel Cu= Copper	Wear parts 4-Roller drive system Ø = 37mm	
V-Nut: St-, CrNi-, Cu-Draht „Standard V-Nut“, oben unverzahnt und glatt, Rollenbezeichnung: „1,0“		V-groove: St-, CrNi-, Cu wire "Standard V-groove", on the top ungeared and plane, rolls description: "1,0"				
Antriebsrollen- Ø (b): Drive rolls- Ø (b): 0,6 + 0,8 0,8 + 1,0 0,9 + 1,2 1,0 + 1,2 1,2 + 1,6	Ersatzset: Spare set: 092-000839-00000 092-000840-00000 092-000841-00000 092-000842-00000 092-000843-00000					
Gegendruckrollenset (a) Set of counter pressure rolls (a) 092-000844-00000 Umrüstung verzahnt → unverzahnt: conversion geared → ungeared: 092-000845-00000						
U-Nut: Al-, Cu-Draht „Option U-Nut“, oben verzahnt, Rollenbezeichnung: „1,0 A2“		U-groove: Al-, Cu wire "Option U-groove", on the top geared-twin rolls, rolls description: "1,0 A2"				
Antriebsrollen- Ø (a+b): Drive rolls- Ø (a+b): 0,8 + 1,0 1,0 + 1,2 1,2 + 1,6 2,4 + 3,2	Ersatzset: Spare set: 092-000869-00000 092-000848-00000 092-000849-00000 092-000870-00000	Umrüstset: Conversion set: 092-000867-00000 092-000846-00000 092-000847-00000 092-000868-00000				
U-Nut gerändelt: Füll-/Röhrchendraht „Option U-Nut gerändelt“, oben verzahnt, ohne Nut gerändelt, Rollenbezeichnung: „1,0-1,2 R“		knurled U-groove: Cored wire "Option knurled U-groove", on the top geared, without knurled groove, rolls description: "1,0-1,2 R"				
Antriebsrollen- Ø (b): Drive rolls- Ø (b): 0,8 / 0,9 + 0,8 / 0,9 1,0 / 1,2 + 1,4 / 1,6 1,4 / 1,6 + 2,0 / 2,4 2,8 + 3,2	Ersatzset: Spare set: 092-000834-00000 092-000835-00000 092-000836-00000 092-000837-00000	Umrüstset: Conversion set: 092-000830-00000 092-000831-00000 092-000832-00000 092-000833-00000				
Gegendruckrollenset (a): Set of counterpressure rolls (a): 092-000838-00000				094-006025-00503		

Figure 10-1

11 Appendix A

11.1 Overview of EWM branches

Headquarters

EWM AG
Dr. Günter-Henle-Straße 8
56271 Mündersbach · Germany
Tel: +49 2680 181-0 · Fax: -244
www.ewm-group.com · info@ewm-group.com

Technology centre

EWM AG
Forststraße 7-13
56271 Mündersbach · Germany
Tel: +49 2680 181-0 · Fax: -144
www.ewm-group.com · info@ewm-group.com



Production, Sales and Service

EWM AG
Dr. Günter-Henle-Straße 8
56271 Mündersbach · Germany
Tel: +49 2680 181-0 · Fax: -244
www.ewm-group.com · info@ewm-group.com

EWM HIGHTEC WELDING (Kunshan) Ltd.
10 Yuanshan Road, Kunshan · New & High-tech Industry Development Zone
Kunshan · Jiangsu · 215300 · People's Republic of China
Tel: +86 512 57867-188 · Fax: -182
www.ewm-kunshan.cn · info@ewm-kunshan.cn

EWM HIGHTEC WELDING AUTOMATION GmbH
Boxbachweg 4
08606 Oelsnitz/V. · Germany
Tel: +49 37421 20-300 · Fax: -318
www.ewm-automation.de · info@ewm-automation.de

TEAMWELDER s.r.o.
Tř. 9. května 718 / 31
407 53 Jířkov – Czech Republic
Tel.: +420 412 358-551 Fax: -504
www.teamwelder.cz · info@teamwelder.cz

Sales and Service Germany

EWM AG
Vertriebs- und Technologiezentrum
Grünauer Fenn 4
14712 Rathenow · Tel: +49 3385 49402-0 · Fax: -20
www.ewm-rathenow.de · info@ewm-rathenow.de

EWM HIGHTEC WELDING GmbH
Lindenstraße 1a
38723 Seesen-Rhüden · Tel: +49 5384 90798-0 · Fax: -20
www.ewm-seesen.de · info@ewm-seesen.de

EWM HIGHTEC WELDING GmbH
Sachsstraße 28
50259 Pulheim · Tel: +49 2234 697-047 · Fax: -048
www.ewm-pulheim.de · info@ewm-pulheim.de

EWM HIGHTEC WELDING GmbH
Vertriebs- und Logistikzentrum
Sälzerstraße 20a
56235 Ransbach-Baumbach · Tel: +49 2623 9276-0 · Fax: -244
www.ewm-ransbach-baumbach.de · info@ewm-ransbach-baumbach.de

EWM HIGHTEC WELDING GmbH
Eiserfelder Straße 300
57080 Siegen · Tel: +49 271 3878103-0 · Fax: -9
www.ewm-siegen.de · info@ewm-siegen.de

EWM HIGHTEC WELDING GmbH
Vertriebs- und Technologiezentrum
Draisstraße 2a
69469 Weinheim · Tel: +49 6201 84557-0 · Fax: -20
www.ewm-weinheim.de · info@ewm-weinheim.de

EWM Schweißtechnik Handels GmbH
Bildstock 9/3-4
88085 Langenargen · Tel: +49 7543 9344-30 · Fax: -50
www.ewm-langenargen.de · info@ewm-langenargen.de

EWM Schweißtechnik Handels GmbH
Rittergasse 1
89143 Blaubeuren · Tel: +49 7344 9191-75 · Fax: -77
www.ewm-blaubeuren.de · info@ewm-blaubeuren.de

EWM Schweißtechnik Handels GmbH
Heinkelstraße 8
89231 Neu-Ulm · Tel: +49 731 7047939-0 · Fax: -15
www.ewm-neu-ulm.de · info@ewm-neu-ulm.de

EWM HIGHTEC WELDING AUTOMATION GmbH
Steinfeldstraße 15
90425 Nürnberg · Tel: +49 911 3841-727 · Fax: -728
www.ewm-automation.de · info@ewm-automation.de

Sales and Service International

EWM HIGHTEC WELDING GmbH
Fichtenweg 1
4810 Gmunden · Austria · Tel: +43 7612 778 02-0 · Fax: -20
www.ewm-gmunden.at · info@ewm-gmunden.at

EWM HIGHTEC WELDING (Kunshan) Ltd.
10 Yuanshan Road, Kunshan · New & High-tech Industry Development Zone
Kunshan · Jiangsu · 215300 · People's Republic of China
Tel: +86 512 57867-188 · Fax: -182
www.ewm-kunshan.cn · info@ewm-kunshan.cn

EWM HIGHTEC WELDING UK Ltd.
Unit 2B Coopies Way · Coopies Lane Industrial Estate
Morpeth · Northumberland · NE61 6JN · Great Britain
Tel: +44 1670 505875 · Fax: -514305
www.ewm-morpeth.co.uk · info@ewm-morpeth.co.uk

EWM HIGHTEC WELDING Sales s.r.o. / Prodejní a poradenské centrum
Tyršova 2106
256 01 Benešov u Prahy · Czech Republic
Tel: +420 317 729-517 · Fax: -712
www.ewm-benesov.cz · info@ewm-benesov.cz

