



EN

Welding machine

Pico 300 cel
Pico 300 cel vrd 12V
Pico 300 cel svrd 12V

099-002032-EW501

Observe additional system documents!

05.03.2019

**Register now
and benefit!**
**Jetzt Registrieren
und Profitieren!**

www.ewm-group.com



General instructions

WARNING



Read the operating instructions!

The operating instructions provide an introduction to the safe use of the products.

- Read and observe the operating instructions for all system components, especially the safety instructions and warning notices!
- Observe the accident prevention regulations and any regional regulations!
- The operating instructions must be kept at the location where the machine is operated.
- Safety and warning labels on the machine indicate any possible risks. Keep these labels clean and legible at all times.
- The machine has been constructed to state-of-the-art standards in line with any applicable regulations and industrial standards. Only trained personnel may operate, service and repair the machine.
- Technical changes due to further development in machine technology may lead to a differing welding behaviour.

In the event of queries on installation, commissioning, operation or special conditions at the installation site, or on usage, please contact your sales partner or our customer service department on +49 2680 181-0.

A list of authorised sales partners can be found at www.ewm-group.com/en/specialist-dealers.

Liability relating to the operation of this equipment is restricted solely to the function of the equipment. No other form of liability, regardless of type, shall be accepted. This exclusion of liability shall be deemed accepted by the user on commissioning the equipment.

The manufacturer is unable to monitor whether or not these instructions or the conditions and methods are observed during installation, operation, usage and maintenance of the equipment.

An incorrectly performed installation can result in material damage and injure persons as a result. For this reason, we do not accept any responsibility or liability for losses, damages or costs arising from incorrect installation, improper operation or incorrect usage and maintenance or any actions connected to this in any way.

© EWM AG

Dr. Günter-Henle-Strasse 8
56271 Mündersbach Germany
Tel.: +49 2680 181-0, Fax: -244
Email: info@ewm-group.com

www.ewm-group.com

The copyright to this document remains the property of the manufacturer.

Copying, including extracts, only permitted with written approval.

The content of this document has been prepared and reviewed with all reasonable care. The information provided is subject to change; errors excepted.

1 Contents

1	Contents	3
2	For your safety	5
2.1	Notes on the use of these operating instructions	5
2.2	Explanation of icons.....	6
2.3	Part of the complete documentation	7
2.4	Safety instructions.....	8
2.5	Transport and installation	12
3	Intended use	13
3.1	Applications.....	13
3.2	Documents which also apply	13
3.2.1	Warranty	13
3.2.2	Declaration of Conformity.....	13
3.2.3	Welding in environments with increased electrical hazards.....	13
3.2.4	Service documents (spare parts and circuit diagrams).....	13
3.2.5	Calibration/Validation	13
4	Machine description – quick overview	14
4.1	Front view / rear view.....	14
4.2	Machine control – Operating elements	16
4.2.1	Welding data display	17
4.2.1.1	Welding current actual value display	17
5	Design and function	18
5.1	Transport and installation	18
5.1.1	Machine cooling.....	18
5.1.2	Workpiece lead, general.....	18
5.1.3	Ambient conditions	19
5.1.3.1	In operation	19
5.1.3.2	Transport and storage.....	19
5.1.4	Adjusting the length of the carrying strap	19
5.1.5	Notes on the installation of welding current leads	20
5.1.6	Stray welding currents	21
5.1.7	Mains connection.....	22
5.1.7.1	Mains configuration	22
5.2	MMA welding	23
5.2.1	Connecting the electrode holder and workpiece lead	23
5.2.2	Welding task selection.....	24
5.2.2.1	Arcforce (welding characteristics)	24
5.2.3	Hotstart	25
5.2.3.1	Hotstart time	25
5.2.3.2	Hotstart current	25
5.2.4	Antistick	25
5.2.5	Expert menu (MMA)	26
5.2.5.1	Arcforce correction (welding characteristics)	26
5.3	TIG welding.....	27
5.3.1	Shielding gas supply (shielding gas cylinder for welding machine)	27
5.3.2	Pressure regulator connection	27
5.3.3	Connecting a TIG welding torch with rotating gas valve	28
5.3.4	Welding task selection.....	28
5.3.5	Gas test – setting the shielding gas volume.....	29
5.3.6	Arc ignition.....	29
5.3.6.1	Liftarc	29

5.3.7	Expert menu (TIG)	30
5.4	Remote control.....	30
5.4.1	RTF1 19POL.....	30
5.4.2	RT1 19POL.....	30
5.5	Dirt filter	31
5.6	Arc length restriction (USP).....	31
5.7	Voltage reducing device.....	31
6	Maintenance, care and disposal	32
6.1	General.....	32
6.2	Cleaning	32
6.2.1	Dirt filter.....	32
6.3	Maintenance work, intervals	33
6.3.1	Daily maintenance tasks.....	33
6.3.2	Monthly maintenance tasks	33
6.3.3	Annual test (inspection and testing during operation)	33
6.4	Disposing of equipment.....	34
7	Rectifying faults.....	35
7.1	Error messages (power source).....	35
7.2	Resetting welding parameters to the factory settings	36
8	Technical data.....	37
8.1	Pico 300 cel.....	37
9	Accessories	38
9.1	Welding torch, electrode holder and workpiece lead	38
9.2	Remote controls and accessories.....	38
9.3	Options.....	38
9.4	General accessories	38
10	Appendix	39
10.1	Parameter overview – setting ranges	39
10.2	Searching for a dealer.....	40

2 For your safety

2.1 Notes on the use of these operating instructions

DANGER

Working or operating procedures which must be closely observed to prevent imminent serious and even fatal injuries.

- Safety notes include the "DANGER" keyword in the heading with a general warning symbol.
- The hazard is also highlighted using a symbol on the edge of the page.

WARNING

Working or operating procedures which must be closely observed to prevent serious and even fatal injuries.

- Safety notes include the "WARNING" keyword in the heading with a general warning symbol.
- The hazard is also highlighted using a symbol in the page margin.

CAUTION

Working or operating procedures which must be closely observed to prevent possible minor personal injury.

- The safety information includes the "CAUTION" keyword in its heading with a general warning symbol.
- The risk is explained using a symbol on the edge of the page.



Technical aspects which the user must observe to avoid material or equipment damage.

Instructions and lists detailing step-by-step actions for given situations can be recognised via bullet points, e.g.:

- Insert the welding current lead socket into the relevant socket and lock.

2.2 Explanation of icons

Symbol	Description	Symbol	Description
	Indicates technical aspects which the user must observe.		Activate and release / Tap / Tip
	Switch off machine		Release
	Switch on machine		Press and hold
			Switch
	Incorrect / Invalid		Turn
	Correct / Valid		Numerical value – adjustable
	Input		Signal light lights up in green
	Navigation		Signal light flashes green
	Output		Signal light lights up in red
	Time representation (e.g.: wait 4 s / actuate)		Signal light flashes red
	Interruption in the menu display (other setting options possible)		
	Tool not required/do not use		
	Tool required/use		

2.3 Part of the complete documentation

These operating instructions are part of the complete documentation and valid only in combination with all other parts of these instructions! Read and observe the operating instructions for all system components, especially the safety instructions!

The illustration shows a general example of a welding system.

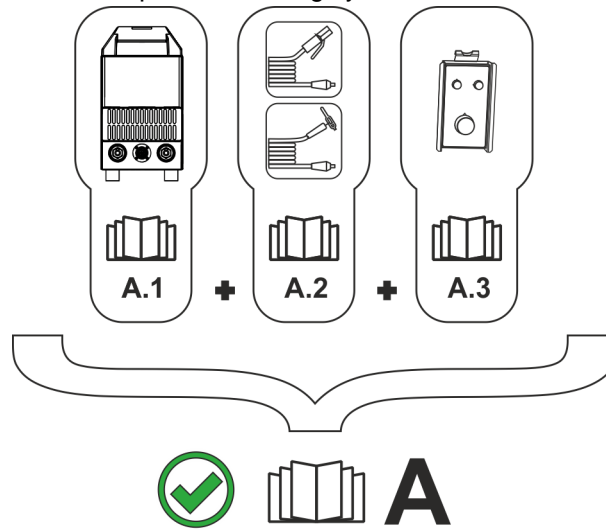

Figure 2-1

Item	Documentation
A.1	Power source
A.2	Electrode holder/welding torch
A.3	Remote control
A	Complete documentation

2.4 Safety instructions

WARNING



Risk of accidents due to non-compliance with the safety instructions!

Non-compliance with the safety instructions can be fatal!

- Carefully read the safety instructions in this manual!
- Observe the accident prevention regulations and any regional regulations!
- Inform persons in the working area that they must comply with the regulations!



Risk of injury from electrical voltage!

Voltages can cause potentially fatal electric shocks and burns on contact. Even low voltages can cause a shock and lead to accidents.

- Never touch live components such as welding current sockets or stick, tungsten or wire electrodes!
- Always place torches and electrode holders on an insulated surface!
- Wear the full personal protective equipment (depending on the application)!
- The machine may only be opened by qualified personnel!
- The device must not be used to defrost pipes!



Hazard when interconnecting multiple power sources!

If a number of power sources are to be connected in parallel or in series, only a technical specialist may interconnect the sources as per standard IEC 60974-9:2010: *Installation and use* and German Accident Prevention Regulation BVG D1 (formerly VBG 15) or country-specific regulations.

Before commencing arc welding, a test must verify that the equipment cannot exceed the maximum permitted open circuit voltage.

- Only qualified personnel may connect the machine.
- When taking individual power sources out of operation, all mains and welding current leads must be safely disconnected from the welding system as a whole. (Hazard due to reverse polarity voltage!)
- Do not interconnect welding machines with pole reversing switch (PWS series) or machines for AC welding since a minor error in operation can cause the welding voltages to be combined, which is not permitted.



Risk of injury due to improper clothing!

During arc welding, radiation, heat and voltage are sources of risk that cannot be avoided. The user has to be equipped with the complete personal protective equipment at all times. The protective equipment has to include:

- Respiratory protection against hazardous substances and mixtures (fumes and vapours); otherwise implement suitable measures such as extraction facilities.
- Welding helmet with proper protection against ionizing radiation (IR and UV radiation) and heat.
- Dry welding clothing (shoes, gloves and body protection) to protect against warm environments with conditions comparable to ambient temperatures of 100 °C or higher and arcing and work on live components.
- Hearing protection against harming noise.



Risk of injury due to radiation or heat!

Arc radiation can lead to skin and eye injuries.

Contact with hot workpieces and sparks can lead to burns.

- Use hand shield or welding helmet with the appropriate safety level (depends on the application).
- Wear dry protective clothing (e.g. hand shield, gloves, etc.) in accordance with the applicable regulations of your country.
- Persons who are not directly involved should be protected with a welding curtain or suitable safety screen against radiation and the risk of blinding!

 **WARNING****Explosion risk!**

Apparently harmless substances in closed containers may generate excessive pressure when heated.

- Move containers with inflammable or explosive liquids away from the working area!
- Never heat explosive liquids, dusts or gases by welding or cutting!

**Fire hazard!**

Due to the high temperatures, sparks, glowing parts and hot slag that occur during welding, there is a risk of flames.

- Be watchful of potential sources of fire in the working area!
- Do not carry any easily inflammable objects, e.g. matches or lighters.
- Ensure suitable fire extinguishers are available in the working area!
- Thoroughly remove any residue of flammable materials from the workpiece prior to starting to weld.
- Only further process workpieces after they have cooled down. Do not allow them to contact any flammable materials!

⚠ CAUTION



Smoke and gases!

Smoke and gases can lead to breathing difficulties and poisoning. In addition, solvent vapour (chlorinated hydrocarbon) may be converted into poisonous phosgene due to the ultraviolet radiation of the arc!

- Ensure that there is sufficient fresh air!
- Keep solvent vapour away from the arc beam field!
- Wear suitable breathing apparatus if appropriate!



Noise exposure!

Noise exceeding 70 dBA can cause permanent hearing damage!

- Wear suitable ear protection!
- Persons located within the working area must wear suitable ear protection!



According to IEC 60974-10, welding machines are divided into two classes of electromagnetic compatibility (the EMC class can be found in the Technical data) > see 8 chapter:



Class A machines are not intended for use in residential areas where the power supply comes from the low-voltage public mains network. When ensuring the electromagnetic compatibility of class A machines, difficulties can arise in these areas due to interference not only in the supply lines but also in the form of radiated interference.



Class B machines fulfil the EMC requirements in industrial as well as residential areas, including residential areas connected to the low-voltage public mains network.

Setting up and operating

When operating arc welding systems, in some cases, electro-magnetic interference can occur although all of the welding machines comply with the emission limits specified in the standard. The user is responsible for any interference caused by welding.

In order to **evaluate** any possible problems with electromagnetic compatibility in the surrounding area, the user must consider the following: (see also EN 60974-10 Appendix A)

- Mains, control, signal and telecommunication lines
- Radios and televisions
- Computers and other control systems
- Safety equipment
- The health of neighbouring persons, especially if they have a pacemaker or wear a hearing aid
- Calibration and measuring equipment
- The immunity to interference of other equipment in the surrounding area
- The time of day at which the welding work must be carried out

Recommendations for **reducing interference emission**

- Mains connection, e.g. additional mains filter or shielding with a metal tube
- Maintenance of the arc welding system
- Welding leads should be as short as possible and run closely together along the ground
- Potential equalization
- Earthing of the workpiece. In cases where it is not possible to earth the workpiece directly, it should be connected by means of suitable capacitors.
- Shielding from other equipment in the surrounding area or the entire welding system



Electromagnetic fields!

The power source may cause electrical or electromagnetic fields to be produced which could affect the correct functioning of electronic equipment such as IT or CNC devices, telecommunication lines, power cables, signal lines and pacemakers.



- Observe the maintenance instructions > see 6.3 chapter!
- Unwind welding leads completely!
- Shield devices or equipment sensitive to radiation accordingly!
- The correct functioning of pacemakers may be affected (obtain advice from a doctor if necessary).

 **CAUTION****Obligations of the operator!**

The respective national directives and laws must be complied with when operating the machine!

- Implementation of national legislation relating to framework directive 89/391/EEC on the introduction of measures to encourage improvements in the safety and health of workers at work and associated individual guidelines.
- In particular, directive 89/655/EEC concerning the minimum safety and health requirements for the use of work equipment by workers at work.
- The regulations applicable to occupational safety and accident prevention in the country concerned.
- Setting up and operating the machine as per IEC 60974.-9.
- Brief the user on safety-conscious work practices on a regular basis.
- Regularly inspect the machine as per IEC 60974.-4.



The manufacturer's warranty becomes void if non-genuine parts are used!

- ***Only use system components and options (power sources, welding torches, electrode holders, remote controls, spare parts and replacement parts, etc.) from our range of products!***
- ***Only insert and lock accessory components into the relevant connection socket when the machine is switched off.***

Requirements for connection to the public mains network

High-performance machines can influence the mains quality by taking current from the mains network. For some types of machines, connection restrictions or requirements relating to the maximum possible line impedance or the necessary minimum supply capacity at the interface with the public network (Point of Common Coupling, PCC) can therefore apply. In this respect, attention is also drawn to the machines' technical data. In this case, it is the responsibility of the operator, where necessary in consultation with the mains network operator, to ensure that the machine can be connected.

2.5 Transport and installation

WARNING



Risk of injury due to improper handling of shielding gas cylinders!
Improper handling and insufficient securing of shielding gas cylinders can cause serious injuries!

- Observe the instructions from the gas manufacturer and any relevant regulations concerning the use of compressed air!
- Do not attach any element to the shielding gas cylinder valve!
- Prevent the shielding gas cylinder from heating up.

CAUTION



Risk of accidents due to supply lines!
During transport, attached supply lines (mains leads, control cables, etc.) can cause risks, e.g. by causing connected machines to tip over and injure persons!

- Disconnect all supply lines before transport!



Risk of tipping!
There is a risk of the machine tipping over and injuring persons or being damaged itself during movement and set up. Tilt resistance is guaranteed up to an angle of 10° (according to IEC 60974-1).

- Set up and transport the machine on level, solid ground.
- Secure add-on parts using suitable equipment.



Risk of accidents due to incorrectly installed leads!
Incorrectly installed leads (mains, control and welding leads or intermediate hose packages) can present a tripping hazard.

- Lay the supply lines flat on the floor (avoid loops).
- Avoid laying the leads on passage ways.



The units are designed for operation in an upright position!
Operation in non-permissible positions can cause equipment damage.

- ***Only transport and operate in an upright position!***



Accessory components and the power source itself can be damaged by incorrect connection!

- ***Only insert and lock accessory components into the relevant connection socket when the machine is switched off.***
- ***Comprehensive descriptions can be found in the operating instructions for the relevant accessory components.***
- ***Accessory components are detected automatically after the power source is switched on.***



Protective dust caps protect the connection sockets and therefore the machine against dirt and damage.

- ***The protective dust cap must be fitted if there is no accessory component being operated on that connection.***
- ***The cap must be replaced if faulty or if lost!***

3 Intended use

WARNING



Hazards due to improper usage!

The machine has been constructed to the state of the art and any regulations and standards applicable for use in industry and trade. It may only be used for the welding procedures indicated at the rating plate. Hazards may arise for persons, animals and material objects if the equipment is not used correctly. No liability is accepted for any damages arising from improper usage!

- The equipment must only be used in line with its designated purpose and by trained or expert personnel!
- Do not improperly modify or convert the equipment!

3.1 Applications

Arc welding machine for MMA DC welding with TIG DC welding with lift arc (touch starting) as secondary process.

3.2 Documents which also apply

3.2.1 Warranty

For more information refer to the "Warranty registration" brochure supplied and our information regarding warranty, maintenance and testing at www.ewm-group.com!

3.2.2 Declaration of Conformity

The labelled product complies with the following EC directives in terms of its design and construction:



- Low Voltage Directive (LVD)
- Electromagnetic Compatibility Directive (EMC)
- Restriction of Hazardous Substance (RoHS)

In case of unauthorised changes, improper repairs, non-compliance with specified deadlines for "Arc Welding Equipment – Inspection and Testing during Operation," and/or prohibited modifications which have not been explicitly authorised by the manufacturer, this declaration shall be voided. An original document of the specific declaration of conformity is included with every product.

3.2.3 Welding in environments with increased electrical hazards



In compliance with IEC / DIN EN 60974, VDE 0544 the machines can be used in environments with an increased electrical hazard.

3.2.4 Service documents (spare parts and circuit diagrams)

WARNING



Do not carry out any unauthorised repairs or modifications!

To avoid injury and equipment damage, the unit must only be repaired or modified by specialist, skilled persons!

The warranty becomes null and void in the event of unauthorised interference.

- Appoint only skilled persons for repair work (trained service personnel)!

Original copies of the circuit diagrams are enclosed with the unit.

Spare parts can be obtained from the relevant authorised dealer.

3.2.5 Calibration/Validation

We hereby confirm that this product was tested with calibrated measuring equipment according to the applicable standards IEC/EN 60974, ISO/EN 17662, EN 50504 and complies with the permissible tolerances. Recommended calibration interval: 12 months.

4 Machine description – quick overview

4.1 Front view / rear view

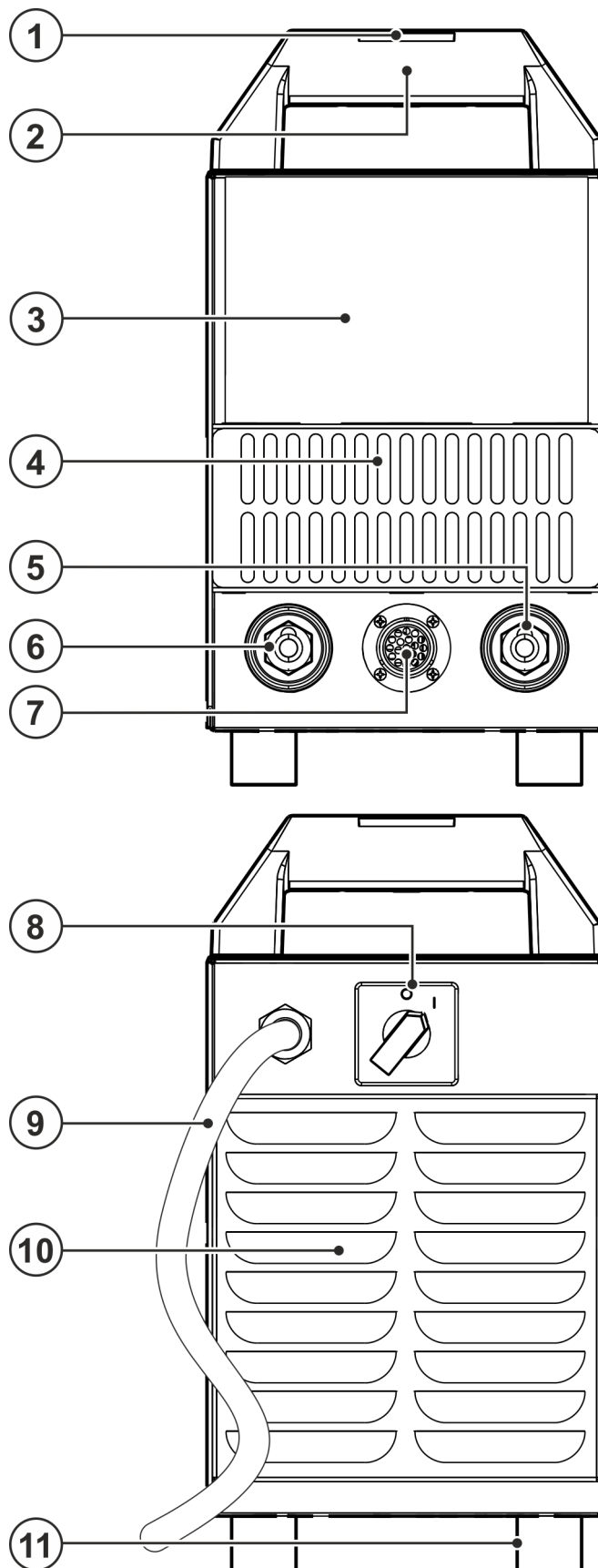





Figure 4-1

Item	Symbol	Description
1		Carrying strap > see 5.1.4 chapter
2		Carrying handle
3		Machine control > see 4.2 chapter
4		Cooling air inlet
5		Connection socket, "-" welding current <ul style="list-style-type: none"> • MMA: Connection of electrode holder or workpiece lead • TIG: Connection of TIG welding torch
6		Connection socket, "+" welding current <ul style="list-style-type: none"> • MMA: Electrode holder or workpiece lead connection • TIG: Connection for workpiece lead
7		Connection socket, 19-pole Remote control connection
8		Main switch, machine on/off
9		Mains connection cable > see 5.1.7 chapter
10		Cooling air outlet
11		Machine feet

4.2 Machine control – Operating elements

The parameters and their setting ranges are described in chapter Parameters Overview - Setting Ranges > see 10.1 chapter.

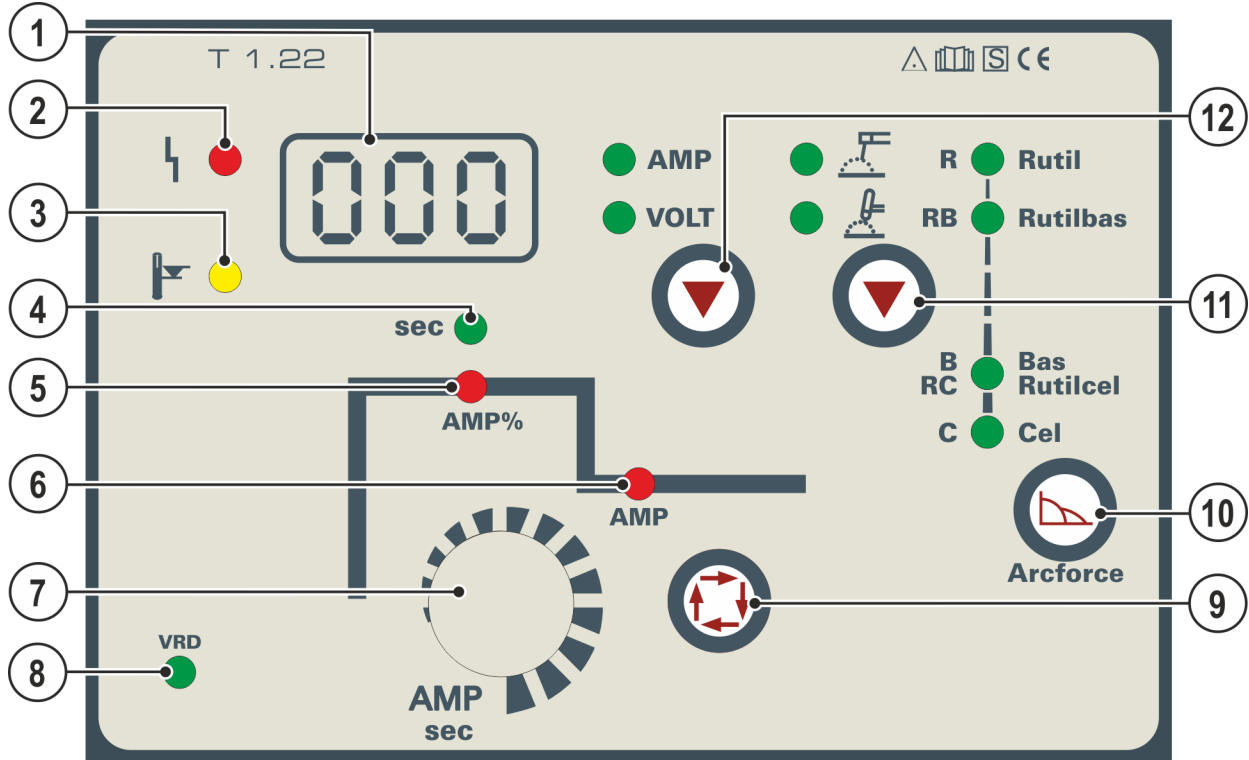

Figure 4-2

Item	Symbol	Description
1		Welding data display (3-digit) Displays the welding parameters and the corresponding values > see 4.2.1 chapter
2		Collective interference signal light For error messages, > see 7 chapter
3		Excess temperature signal light In case of excess temperature, temperature monitors de-activate the power unit, and the excess temperature control lamp comes on. Once the machine has cooled down, welding can continue without any further measures.
4	sec	Hotstart time signal light
5	AMP%	Hotstart current signal light
6	AMP	Main current signal light I _{min} to I _{max} (1 A increments)
7		Welding parameter setting rotary transducer Setting of welding current and other welding parameter and their values
8	VRD	Voltage reduction device (VRD) signal light > see 5.7 chapter
9		Select welding parameters button This button is used to select the welding parameters depending on the welding process and operating mode used.
10		“Arcforce” button (welding characteristics) according to electrode type
11		Welding procedure push-button ----- TIG welding ----- MMA welding
12		Switch display button AMP----- Welding current display VOLT --- Welding voltage display

4.2.1 Welding data display

All relevant welding parameters with their values are shown depending on the welding procedure selected and the associated functions. Machine parameters and error codes are shown as well in a unique manner. The meaning of the parameters and values shown is explained in the relevant chapter for the function.

4.2.1.1 Welding current actual value display

The welding current in the welding data display is displayed as nominal value at the factory. The welding current display can be determined by switching the parameter r_{CD} to actual values in the respective expert menu:

MMA welding > see 5.2.5 chapter

TIG welding > see 5.3.7 chapter

- In idle mode (when no welding current is flowing) the nominal value is displayed
- If welding current is flowing, the welding data display is switched to the actual value
- After welding, the nominal value is displayed again

5 Design and function

5.1 Transport and installation

WARNING



Risk of accident due to improper transport of machines that must not be lifted! Do not lift or suspend the machine! The machine can drop and cause injuries! The handles, straps or brackets are suitable for transport by hand only!

- The machine must not be suspended or lifted using a crane.



The units are designed for operation in an upright position! Operation in non-permissible positions can cause equipment damage.

- ***Only transport and operate in an upright position!***



Accessory components and the power source itself can be damaged by incorrect connection!

- ***Only insert and lock accessory components into the relevant connection socket when the machine is switched off.***
- ***Comprehensive descriptions can be found in the operating instructions for the relevant accessory components.***
- ***Accessory components are detected automatically after the power source is switched on.***

5.1.1 Machine cooling



Insufficient ventilation results in a reduction in performance and equipment damage.

- ***Observe the ambient conditions!***
- ***Keep the cooling air inlet and outlet clear!***
- ***Observe the minimum distance of 0.5 m from obstacles!***

5.1.2 Workpiece lead, general

CAUTION



Risk of burning due to incorrect welding current connection!

If the welding current plugs (machine connections) are not locked or if the workpiece connection is contaminated (paint, corrosion), these connections and leads can heat up and cause burns when touched!

- Check welding current connections on a daily basis and lock by turning to the right when necessary.
- Clean workpiece connection thoroughly and secure properly. Do not use structural parts of the workpiece as welding current return lead!

5.1.3 Ambient conditions



The machine must not be operated in the open air and must only be set up and operated on a suitable, stable and level base!

- The operator must ensure that the ground is non-slip and level, and provide sufficient lighting for the place of work.
- Safe operation of the machine must be guaranteed at all times.



Equipment damage due to contamination!

Unusually high amounts of dust, acids, corrosive gases or substances can damage the machine (observe maintenance intervals > see 6.3 chapter).

- Avoid large amounts of smoke, steam, oily fumes, grinding dust and corrosive ambient air!

5.1.3.1 In operation

Temperature range of the ambient air:

- -25 °C to +40 °C (-13 °F to 104 °F)

Relative humidity:

- up to 50 % at 40 °C (104 °F)
- up to 90 % at 20 °C (68 °F)

5.1.3.2 Transport and storage

Storage in a closed room, temperature range of the ambient air:

- -30 °C to +70 °C (-22 °F to 158 °F)

Relative humidity

- up to 90 % at 20 °C (68 °F)

5.1.4 Adjusting the length of the carrying strap

To demonstrate adjustment, lengthening the strap is shown in the figure. To shorten, the strap's loops must be inched in the opposite direction.

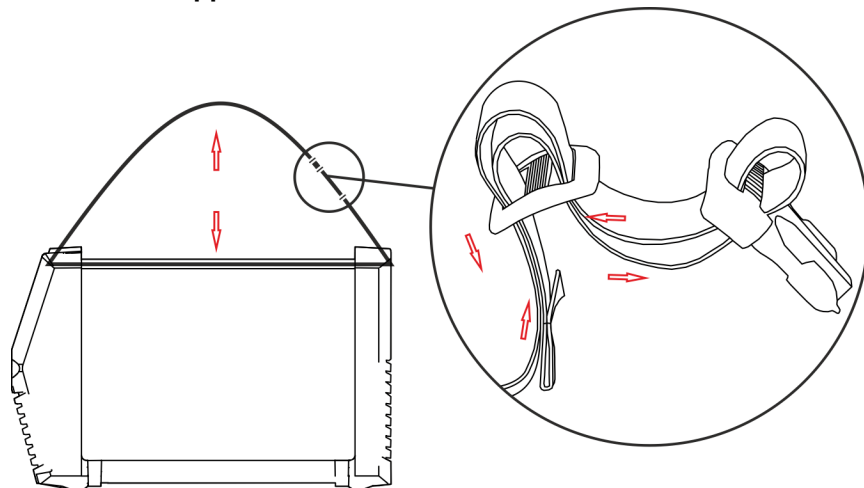

Figure 5-1

5.1.5 Notes on the installation of welding current leads

- Incorrectly installed welding current leads can cause faults in the arc (flickering).
- Lay the workpiece lead and hose package of power sources without HF igniter (MIG/MAG) for as long and as close as possible in parallel.
- Lay the workpiece lead and hose package of power sources with HF igniter (TIG) for as long as possible in parallel with a distance of 20 cm to avoid HF sparkover.
- Always keep a distance of at least 20 cm to leads of other power sources to avoid interferences
- Always keep leads as short as possible! For optimum welding results max. 30 m (welding lead + intermediate hose package + torch lead).

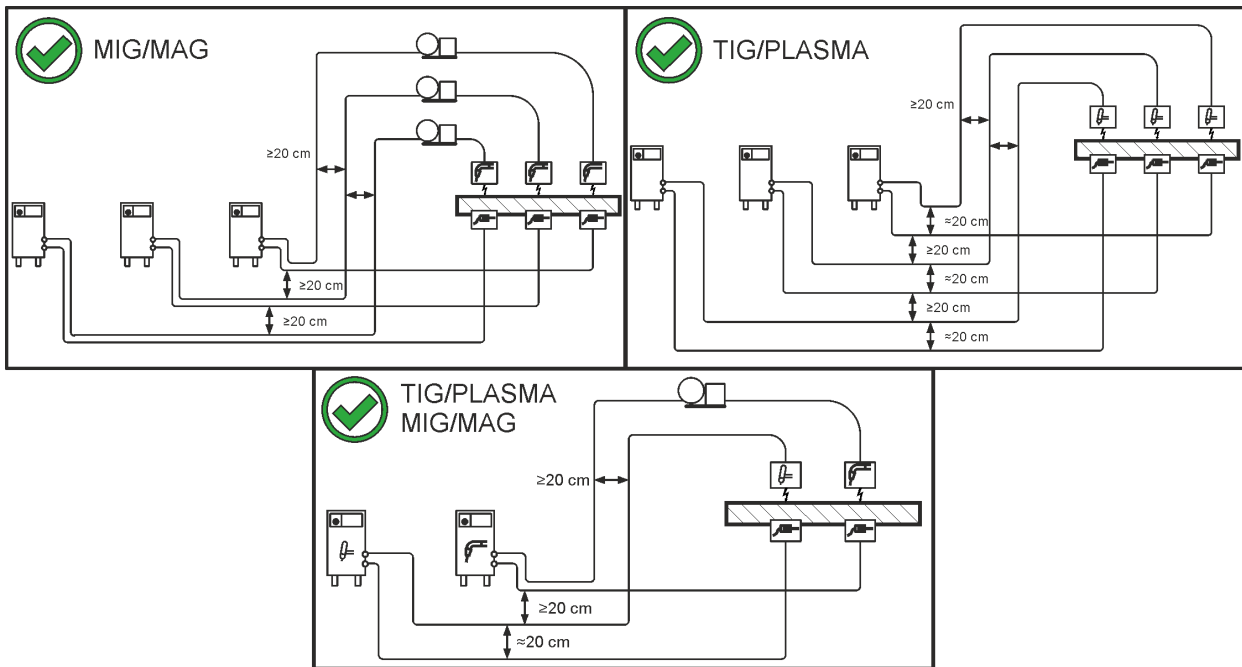

Figure 5-2

- Use an individual welding lead to the workpiece for each welding machine!

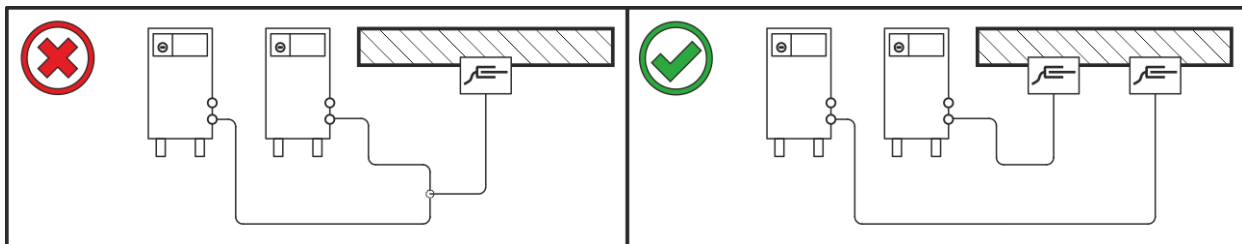

Figure 5-3

- Fully unroll welding current leads, torch hose packages and intermediate hose packages. Avoid loops!
- Always keep leads as short as possible!

Lay any excess cable lengths in meanders.

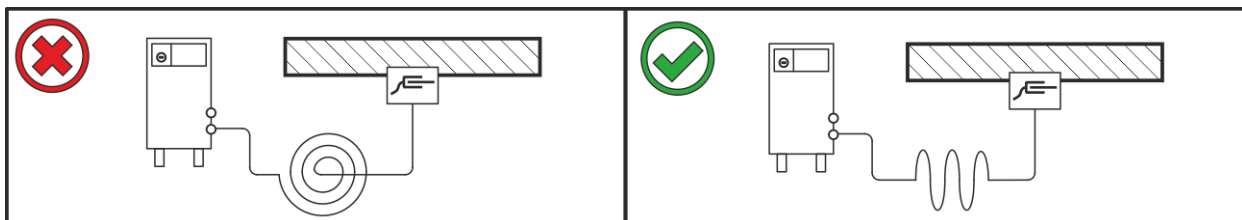

Figure 5-4

5.1.6 Stray welding currents

⚠ WARNING**Risk of injury due to stray welding currents!**

Stray welding currents can destroy protective earth conductors, damage machines and electronic devices and cause overheating of components, leading to fire.

- Check that all welding current connections are firmly secured and electrical connections are in perfect condition.
- Set up, attach or suspend all conductive power source components such as casing, transport vehicles and crane frames so they are insulated.
- Do not place any other electronic devices such as drills or angle grinders on the power source, transport vehicle or crane frames unless they are insulated.
- Always put welding torches and electrode holders on an insulated surface when they are not in use.

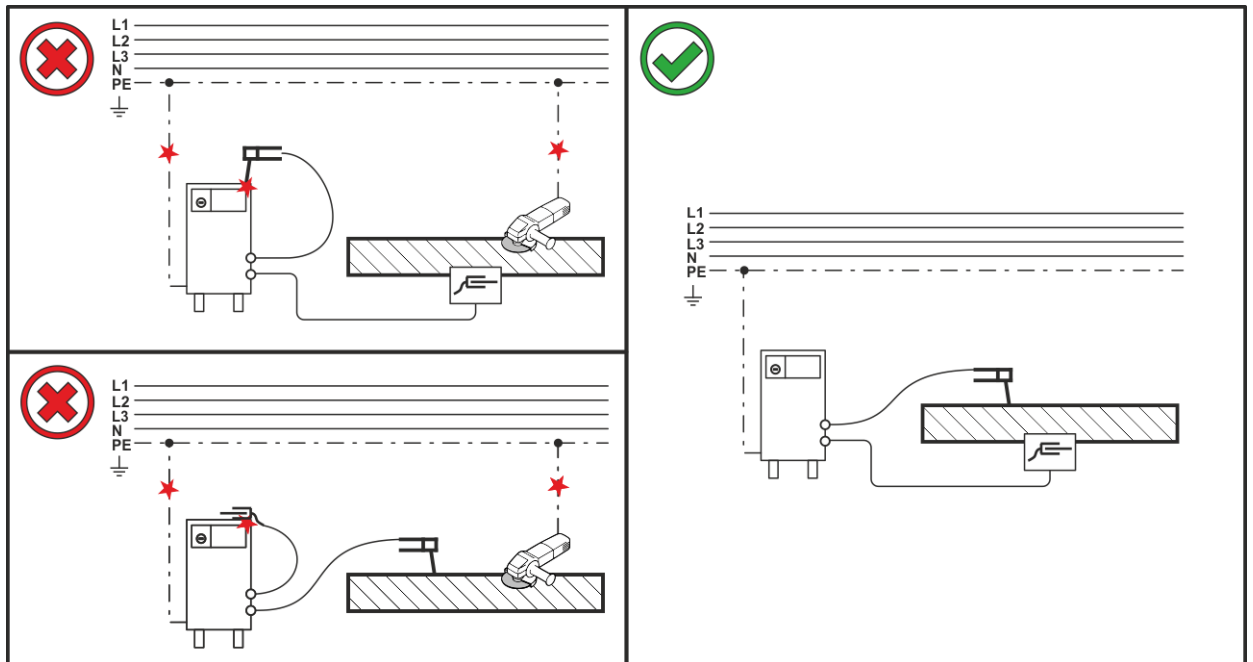

Figure 5-5

5.1.7 Mains connection

⚠ DANGER



Hazards caused by improper mains connection!

An improper mains connection can cause injuries or damage property!

- The connection (mains plug or cable), the repair or voltage adjustment of the device must be carried out by a qualified electrician in accordance with the respective local laws or national regulations!
- The mains voltage indicated on the rating plate must match the supply voltage.
- Only operate machine using a socket that has correctly fitted protective earth.
- Mains plug, socket and lead must be checked by a qualified electrician on a regular basis!
- When operating the generator, always ensure it is earthed as stipulated in the operating instructions. The network created must be suitable for operating machines according to protection class I.

5.1.7.1 Mains configuration

The machine may be connected to:

- a three-phase system with four conductors and an earthed neutral conductor
- a three-phase system with three conductors of which any one can be earthed, e.g. the outer conductor

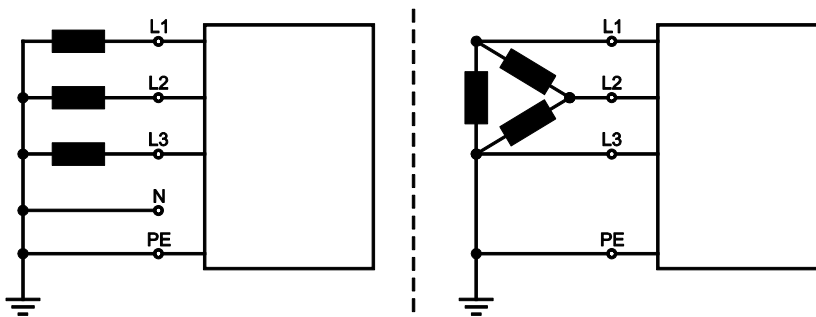

Figure 5-6

Legend

Item	Designation	Colour code
L1	Outer conductor 1	brown
L2	Outer conductor 2	black
L3	Outer conductor 3	grey
N	Neutral conductor	blue
PE	Protective conductor	green-yellow

- Insert mains plug of the switched-off machine into the appropriate socket.

5.2 MMA welding

⚠ CAUTION



Risk of crushing and burns!

When changing stick electrodes there is a risk of crushing and burns!

- Wear appropriate and dry protective gloves.
- Use an insulated pair of tongs to remove the used stick electrode or to move welded workpieces.

5.2.1 Connecting the electrode holder and workpiece lead

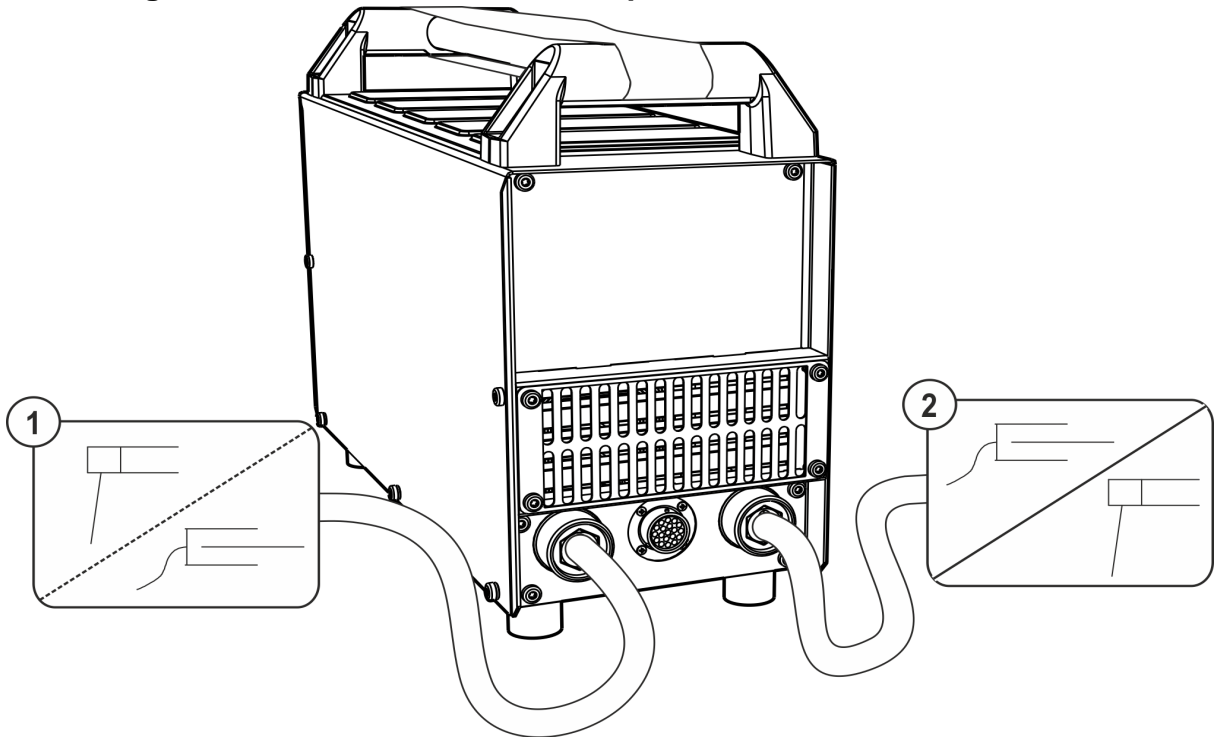

Figure 5-7

Item	Symbol	Description
1		Electrode holder
2		Connection socket for "+" welding current Electrode holder or workpiece lead connection
3		Workpiece
4		Connection socket, "-" welding current Workpiece lead or electrode holder connection

- Insert cable plug of the electrode holder into either the "+" or "-" welding current connection socket and lock by turning to the right.
- Insert cable plug of the workpiece lead into either the "+" or "-" welding current connection socket and lock by turning to the right.

Polarity depends on the instructions from the electrode manufacturer given on the electrode packaging.

5.2.2 Welding task selection

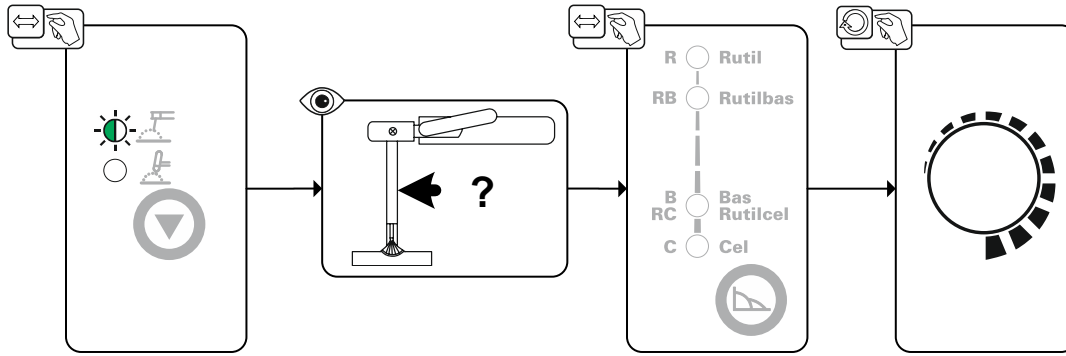
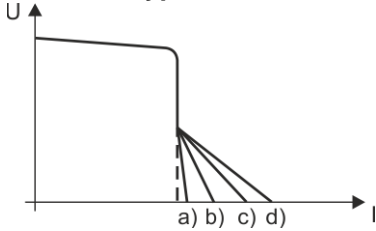

Figure 5-8

5.2.2.1 Arcforce (welding characteristics)

During the welding process, arcforce prevents the electrode sticking in the weld pool with increases in current. This makes it easier to weld large-drop melting electrode types at low current strengths with a short arc in particular.

Electrode type allocation



Item	Electrode type	
a)	R	rutile
b)	RB	rutile basic
c)	B/RC	basic and rutile/cellulose
d)	C	cellulose

Figure 5-9

The electrode characteristics you can select at the machine control are guiding values. Each characteristic can be optimised according to electrode type and the related welding properties > see 5.2.5 chapter.

5.2.3 Hotstart

The function hot start ensures a secure igniting of the arc and a sufficient heating to the still cold parent metal at the beginning of the welding process. The ignition takes place here with increased current (hot start current) over a certain time (hot start time).

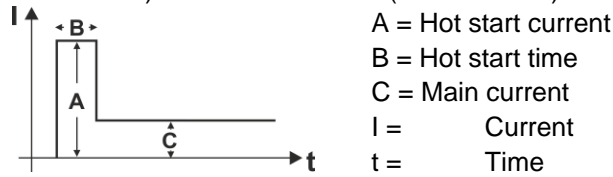

Figure 5-10

5.2.3.1 Hotstart time

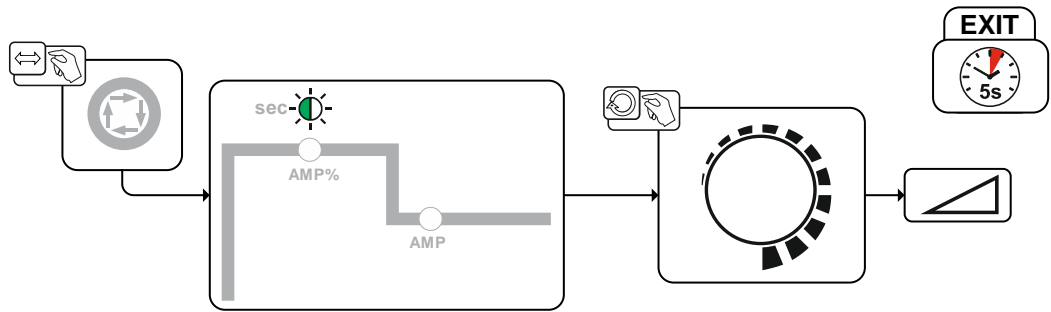

Figure 5-11

5.2.3.2 Hotstart current

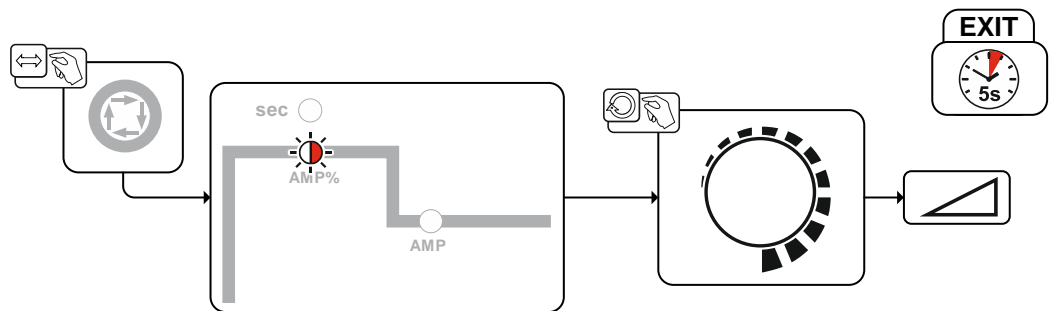
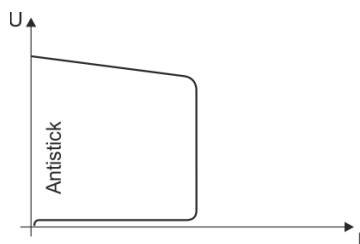

Figure 5-12

5.2.4 Antistick



The Antistick feature prevents the electrode from annealing.

Should the electrode stick despite the Arcforce feature, the machine automatically switches to the minimum current within approx. one second. This prevents the electrode from annealing. Check the welding current setting and correct for the welding task in hand.

Figure 5-13

5.2.5 Expert menu (MMA)

The Expert menu has adjustable parameters stored that don't require regular setting. The number of parameters shown may be limited, e.g. if a function is deactivated.

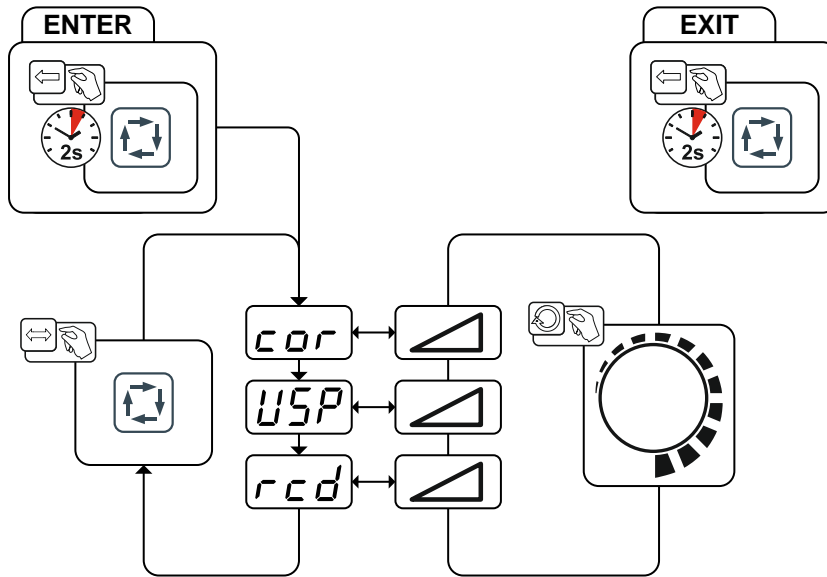

Figure 5-14

Display	Setting/selection
	Arcforce correction > see 5.2.5.1 chapter <ul style="list-style-type: none"> • Increase value > harder arc • Decrease value > softer arc
	Arc length restriction > see 5.6 chapter <ul style="list-style-type: none"> ----- Function switched on ----- Function switched off
	Welding current actual value display > see 4.2.1.1 chapter <ul style="list-style-type: none"> ----- Actual value display ----- Nominal value display

The setting ranges for the parameter values are summarised in the Parameter overview section > see 10.1 chapter.

5.2.5.1 Arcforce correction (welding characteristics)

Example:

You are using a rutile/basic electrode type and set "Rutilbas" accordingly on the machine control. When welding the electrode type, you specify a hard or aggressive arc. You should now change the arcforce setting in the direction of "less arcforce – softer arc" until the required result is achieved.

5.3 TIG welding

5.3.1 Shielding gas supply (shielding gas cylinder for welding machine)

⚠ WARNING



Risk of injury due to improper handling of shielding gas cylinders! Improper handling and insufficient securing of shielding gas cylinders can cause serious injuries!

- Place shielding gas cylinder into the designated holder and secure with fastening elements (chain/belt)!
- Attach the fastening elements within the upper half of the shielding gas cylinder!
- The fastening elements must tightly enclose the shielding gas cylinder!

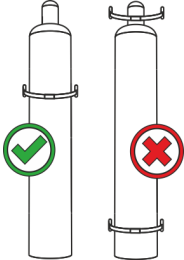

-  **An unhindered shielding gas supply from the shielding gas cylinder to the welding torch is a fundamental requirement for optimum welding results. In addition, a blocked shielding gas supply may result in the welding torch being destroyed.**
- **All shielding gas connections must be gas tight.**

5.3.2 Pressure regulator connection

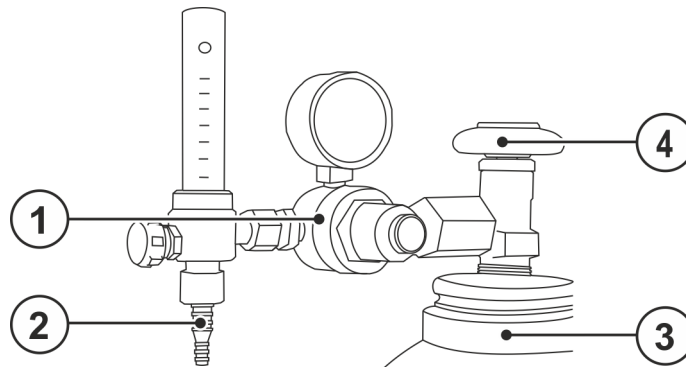

Figure 5-15

Item	Symbol	Description
1		Pressure regulator
2		Output side of the pressure regulator
3		Shielding gas cylinder
4		Cylinder valve

- Before connecting the pressure regulator to the gas cylinder, open the cylinder valve briefly to blow out any dirt.
- Tighten the pressure regulator screw connection on the gas bottle valve to be gas-tight.
- Screw gas hose connection crown nut onto the output side of the pressure regulator.

5.3.3 Connecting a TIG welding torch with rotating gas valve

Prepare welding torch according to the welding task in hand (see operating instructions for the torch).

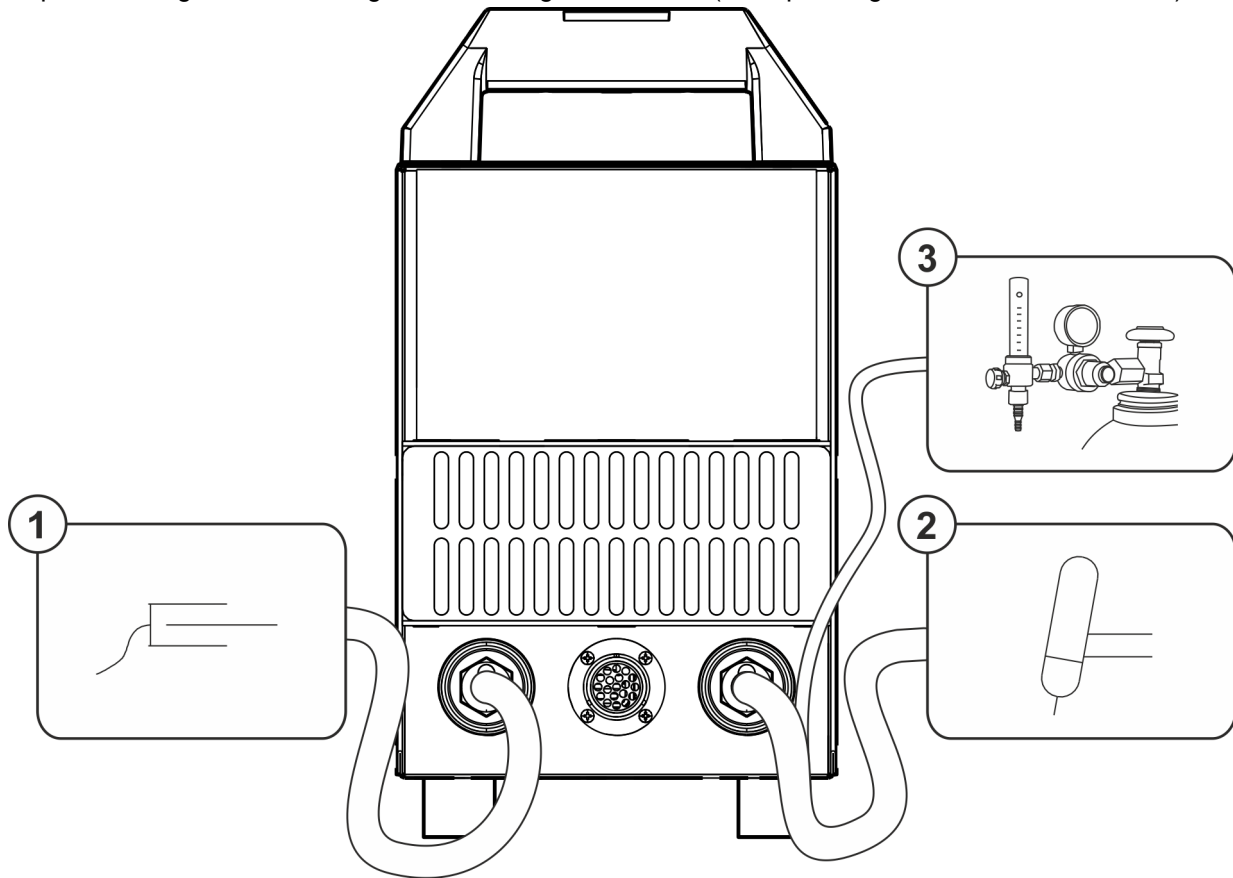

Figure 5-16

Item	Symbol	Description
1		Workpiece
2		Welding torch
3		Output side of the pressure regulator

- Insert the welding current plug on the welding torch into the welding current connection socket and lock by turning to the right.
- Insert the cable plug on the work piece lead into the "+" welding current connection socket and lock by turning to the right.
- Screw the shielding gas hose of the welding torch to the pressure regulator outlet.

If the rotary gas valve is open, the shielding gas flows permanently from the welding torch (no adjustment with a separate gas valve). The rotary valve must be opened before each welding procedure and closed after each welding procedure.

5.3.4 Welding task selection

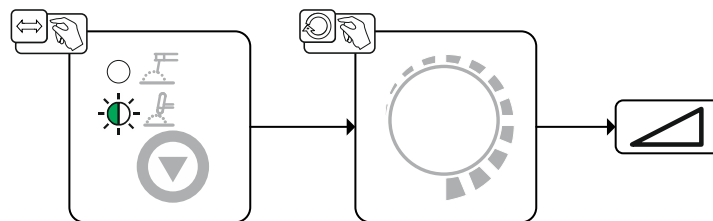

Figure 5-17

5.3.5 Gas test – setting the shielding gas volume

⚠ CAUTION



Electric shocks!

When setting the shielding gas quantity, high voltage ignition pulses or open circuit voltage are applied at the welding torch; these can lead to electric shocks and burning on contact.

- Keep the welding torch electrically insulated from persons, animals or equipment during the setting procedure.

If the shielding gas setting is too low or too high, this can introduce air to the weld pool and may cause pores to form. Adjust the shielding gas quantity to suit the welding task!

Rule of thumb for the gas flow rate:

Diameter of gas nozzle in mm corresponds to gas flow in l/min.

Example: 7mm gas nozzle corresponds to 7l/min gas flow.

- Press the torch trigger and set the shielding gas quantity with the flow gauge of the pressure regulator.

5.3.6 Arc ignition

5.3.6.1 Liftarc

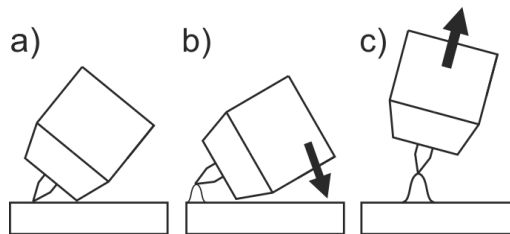

Figure 5-18

The arc ignites through contact with the workpiece:

- a) Carefully place the torch gas nozzle and tungsten electrode tip against the workpiece (lift arc current flows independent of the set main current)
- b) Angle the torch above the torch gas nozzle until the distance between electrode tip and workpiece is approx. 2–3 mm (arc ignites, current increases to the set main current).
- c) Lift the torch off and bring into normal position.

Complete the welding task: Remove the torch from the workpiece so that the arc extinguishes.

5.3.7 Expert menu (TIG)

The Expert menu has adjustable parameters stored that don't require regular setting. The number of parameters shown may be limited, e.g. if a function is deactivated.

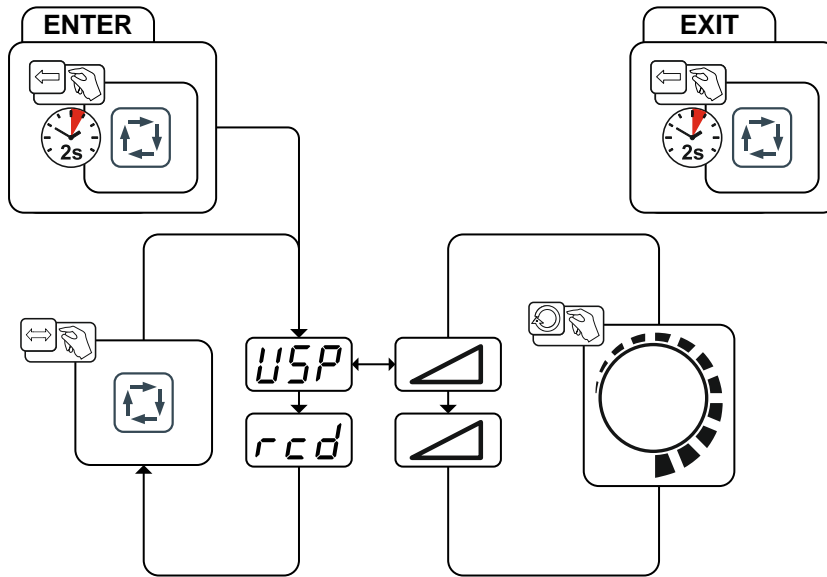

Figure 5-19

Display	Setting/selection
	Arc length restriction > see 5.6 chapter <input type="checkbox"/> on ----- Function switched on <input type="checkbox"/> off ----- Function switched off
	Welding current actual value display > see 4.2.1.1 chapter <input type="checkbox"/> on ----- Actual value display <input type="checkbox"/> off ----- Nominal value display

The setting ranges for the parameter values are summarised in the Parameter overview section > see 10.1 chapter.

5.4 Remote control

The remote controls are operated on the 19-pole remote control connection socket (analogue).

5.4.1 RTF1 19POL

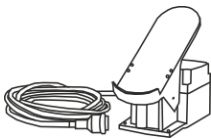

Features

- Infinitely adjustable welding current (0% to 100%) depending on the preselected main current on the welding machine.

5.4.2 RT1 19POL



Functions

- Infinitely adjustable welding current (0% to 100%) depending on the preselected main current on the welding machine.

5.5 Dirt filter

These accessory components can be retrofitted as an option > see 9 chapter.

The duty cycle of the welding machine decreases as an effect of the reduced cooling air volume. The dirt filter must be removed at regular intervals and cleaned by blowing out with compressed air (depending on the level of soiling).

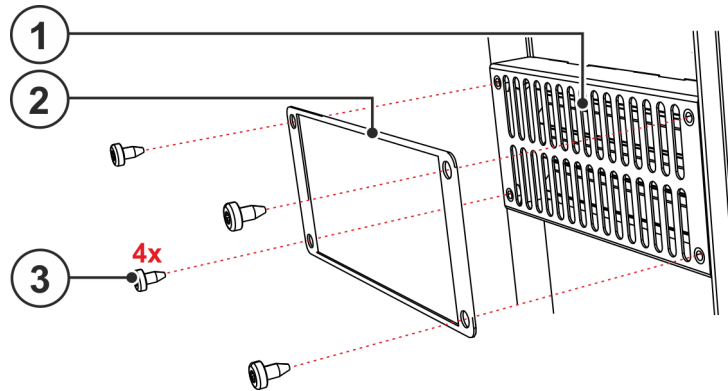

Figure 5-20

Item	Symbol	Description
1		Cooling air inlet
2		Dirt filter with fixing plate
3		4 fixing screws for dirt filter

- Fix dirt filter with 4 fixing screws on the front of the casing (cooling air inlet) of the welding machine.

5.6 Arc length restriction (USP)

The arc length restriction **USP** function stops the welding process when an excessive arc voltage is detected (unusually high gap between electrode and workpiece). This function can be adjusted in the corresponding Expert menu, depending on the process:

MMA welding > see 5.2.5 chapter

TIG welding > see 5.3.7 chapter

5.7 Voltage reducing device

Only machine variants with the (VRD/SVRD/AUS/RU) code are equipped with a voltage reduction device (VRD). The VRD is used for increased safety, especially in hazardous environments such as shipbuilding, pipe construction or mining.

A VRD is mandatory in some countries and required by many on-site safety instructions for power sources.

The VRD > see 4.2 chapter signal light is illuminated when the voltage reduction device is operating without fault and the output voltage is reduced to a value specified in the relevant standard (see technical data > see 8 chapter).

6 Maintenance, care and disposal

6.1 General

DANGER



Risk of injury due to electrical voltage after switching off!

Working on an open machine can lead to fatal injuries!

Capacitors are loaded with electrical voltage during operation. Voltage remains present for up to four minutes after the mains plug is removed.

1. Switch off machine.
2. Remove the mains plug.
3. Wait for at last 4 minutes until the capacitors have discharged!

WARNING



Incorrect maintenance, testing and repair!

Maintenance, testing and repair of the machine may only be carried out by skilled and qualified personnel. A qualified person is one who, because of his or her training, knowledge and experience, is able to recognise the dangers that can occur while testing welding power sources as well as possible subsequent damage, and who is able to implement the required safety procedures.

Observe the maintenance instructions > see 6.3 chapter.

- In the event that the provisions of one of the below-stated tests are not met, the machine must not be operated again until it has been repaired and a new test has been carried out!

Repair and maintenance work may only be performed by qualified authorised personnel; otherwise the right to claim under warranty is void. In all service matters, always consult the dealer who supplied the machine. Return deliveries of defective equipment subject to warranty may only be made through your dealer. When replacing parts, use only original spare parts. When ordering spare parts, please quote the machine type, serial number and item number of the machine, as well as the type designation and item number of the spare part.

Under the specified ambient conditions and normal working conditions this machine is essentially maintenance-free and requires just a minimum of care.

Contamination of the machine may impair service life and duty cycle. The cleaning intervals depend on the ambient conditions and the resulting contamination of the machine. The minimum interval is every six months.

6.2 Cleaning

- Clean the outer surfaces with a moist cloth (no aggressive cleaning agents).
- Purge the machine venting channel and cooling fins (if present) with oil- and water-free compressed air. Compressed air may overspeed and destroy the machine fans. Never direct the compressed air directly at the machine fans. Mechanically block the fans, if required.
- Check the coolant for contaminants and replace, if necessary.

6.2.1 Dirt filter

The duty cycle of the welding machine decreases as an effect of the reduced cooling air volume. The dirt filter must be removed at regular intervals and cleaned by blowing out with compressed air (depending on the level of soiling).

6.3 Maintenance work, intervals

6.3.1 Daily maintenance tasks

Visual inspection

- Mains supply lead and its strain relief
- Gas cylinder securing elements
- Check hose package and power connections for exterior damage and replace or have repaired by specialist staff as necessary!
- Gas tubes and their switching equipment (solenoid valve)
- Check that all connections and wearing parts are hand-tight and tighten if necessary.
- Check correct mounting of the wire spool.
- Wheels and their securing elements
- Transport elements (strap, lifting lugs, handle)
- Other, general condition

Functional test

- Operating, message, safety and adjustment devices (Functional test)
- Welding current cables (check that they are fitted correctly and secured)
- Gas tubes and their switching equipment (solenoid valve)
- Gas cylinder securing elements
- Check correct mounting of the wire spool.
- Check that all screw and plug connections and replaceable parts are secured correctly, tighten if necessary.
- Remove any spatter.
- Clean the wire feed rollers on a regular basis (depending on the degree of soiling).

6.3.2 Monthly maintenance tasks

Visual inspection

- Casing damage (front, rear and side walls)
- Wheels and their securing elements
- Transport elements (strap, lifting lugs, handle)
- Check coolant tubes and their connections for impurities

Functional test

- Selector switches, command devices, emergency stop devices, voltage reducing devices, message and control lamps
- Check that the wire guide elements (inlet nipple, wire guide tube) are fitted securely.
- Check coolant tubes and their connections for impurities
- Check and clean the welding torch. Deposits in the torch can cause short circuits and have a negative impact on the welding result, ultimately causing damage to the torch.

6.3.3 Annual test (inspection and testing during operation)

A periodic test according to IEC 60974-4 "Periodic inspection and test" has to be carried out. In addition to the regulations on testing given here, the relevant local laws and regulations must also be observed. For more information refer to the "Warranty registration" brochure supplied and our information regarding warranty, maintenance and testing at www.ewm-group.com!

6.4 Disposing of equipment



Proper disposal!

The machine contains valuable raw materials, which should be recycled, and electronic components, which must be disposed of.

- **Do not dispose of in household waste!**
- **Observe the local regulations regarding disposal!**
- According to European provisions (Directive 2012/19/EU on Waste of Electrical and Electronic Equipment), used electric and electronic equipment may no longer be placed in unsorted municipal waste. It must be collected separately. The symbol depicting a waste container on wheels indicates that the equipment must be collected separately.
This machine has to be disposed of, or recycled, in accordance with the waste separation systems in use.
- According to German law (law governing the distribution, taking back and environmentally correct disposal of electric and electronic equipment (ElektroG)), used machines are to be placed in a collection system separate from unsorted municipal waste. The public waste management utilities (communities) have created collection points at which used equipment from private households can be disposed of free of charge.
- Information about returning used equipment or about collections can be obtained from the respective municipal administration office.
- In addition to this, returns are also possible throughout Europe via EWM sales partners.

7 Rectifying faults

All products are subject to rigorous production checks and final checks. If, despite this, something fails to work at any time, please check the product using the following flowchart. If none of the fault rectification procedures described leads to the correct functioning of the product, please inform your authorised dealer.

7.1 Error messages (power source)

A welding machine error is indicated by the collective fault signal lamp (A1) lighting up and an error code (see table) being displayed in the machine control display. In the event of a machine error, the power unit shuts down.

- If multiple errors occur, these are displayed in succession.
- Document machine errors and inform service staff as necessary.

Error message	Possible cause	Remedy
"E 1"	Electronics error	Switch the machine off and back on again. If the error persists, inform the service dept.
"E 2"	Temperature error	Allow machine to cool down.
"E 3"	Electronics error	See "E 1".
"E 4"	Electronics error	See "E 1".
"E 5"	Electronics error	See "E 1".
"E 6"	Balancing error in voltage recording	Switch off the machine, place the electrode holder in an insulated position and switch the machine back on. If the error persists, inform the service dept.
"E 7"	Balancing error in current recording	
"E 8"	Error in one of the electronics supply voltages	Switch the machine off and back on again. If the error persists, inform the service dept.
"E 9"	Mains undervoltage	Switch off the machine and check the mains voltage.
"E10"	Secondary excess voltage	Switch the machine off and back on again. If the error persists, inform the service dept.
"E11"	Mains excess voltage	Switch off the machine and check the mains voltage.
"E12"	Voltage reduction error (VRD)	Switch the machine off and back on again. If the error persists, inform the service dept.

7.2 Resetting welding parameters to the factory settings

All customised welding parameters that are stored will be replaced by the factory settings.

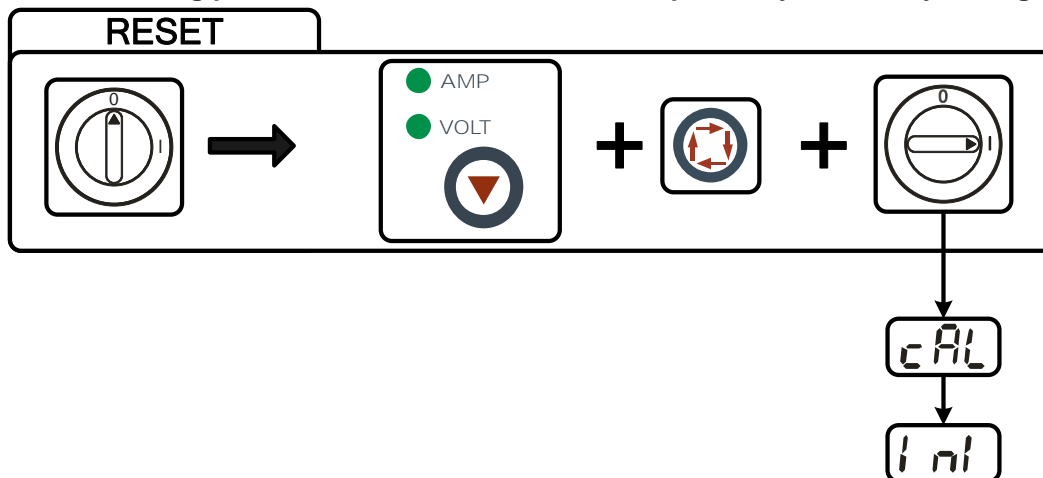



Figure 7-1

Display	Setting/selection
	Calibration The machine will be calibrated for approx 2 seconds each time it is switched on.
	Initialising Keep the push-button pressed until is shown on the display.

8 Technical data

Performance specifications and guarantee only in connection with original spare and replacement parts!

8.1 Pico 300 cel

	MMA	TIG
Welding current (I_2)	10 A to 300 A	
Welding voltage according to standard (U_2)	20,4 V to 32,0 V	10,4 V to 22,0 V
Duty cycle DC at 40° C ^[1]		
25 %	300 A	-
30 %	-	300 A
60 %	220 A	240 A
100 %	170 A	190 A
Open circuit voltage (U_0/U_r)	107 V / 99 V	107 V / 12 V
Open circuit voltage (U_0/U_r) - VRD	107 V / 12 V	
Open circuit voltage (U_0/U_r) - SVRD	107 V / 12 V	
Mains voltage (Tolerance) / Frequency	3 x 400 V (-25 % to +20 %) / 50/60 Hz	
mains fuse ^[2]	3 x 10 A	
Mains connection cable	H07RN-F4G2,5	
max. Connected load (S_1)	12,1 kVA	8,3 kVA
Generator rating (Rec.)	16 kVA	
Cos ϕ / efficiency	0,99 / 88 %	
Protection class / Overvoltage category	I / III	
Contamination level	3	
Insulation class / protection classification	H / IP 23	
Residual current circuit breaker	Type B (recommended)	
Noise level ^[3]	<70 dB(A)	
Ambient temperature	-25 °C to +40 °C	
Machine cooling	Fan (AF)	
Torch cooling	gas	
Workpiece lead (min.)	50 mm ²	
EMC class	A	
Safety marking	CE /  / 	
Standards used	See declaration of conformity (appliance documents)	
Dimensions L / B / H	490 x 186 x 350 mm / 19.3 x 7.3 x 13.8 inch	
Weight	16,5 kg / 36.4 lb.	

^[1] Load cycle: 10 min. (60 % DC \triangleq 6 min. welding, 4 min. pause)

^[2] Safety fuses are recommended DIAZED xxA gG. When using automatic cutouts, the "C" trigger characteristic must be used.

^[3] Noise level during idle mode and operation under standard load according to IEC 60974- 1 at the maximum operating point.

9 Accessories

9.1 Welding torch, electrode holder and workpiece lead

Type	Designation	Item no.
EH50 4M	Electrode holder	092-000004-00000
WK50QMM 4M KL	Workpiece cable, clamp	092-000003-00000
TIG 26V 4M	ABITIG 26 V 4 m BCC-1 BHC-01	094-010979-00000

9.2 Remote controls and accessories

Type	Designation	Item no.
RT1 19POL	Remote control current	090-008097-00000
RA5 19POL 5M	Remote control e.g. connection cable	092-001470-00005
RA10 19POL 10m	Remote control e.g. connection cable	092-001470-00010
RA20 19POL 20m	Remote control e.g. connection cable	092-001470-00020
RTF1 19POL 5 M	Foot-operated remote control current with connection cable	094-006680-00000
RV5M19 19POLE 5M	Extension cable	092-000857-00000

9.3 Options





Type	Designation	Item no.
ON Filter TG.0005	Retrofit option, contamination filter for air inlet	092-001856-00000

9.4 General accessories

Type	Designation	Item no.
DM 842 Ar/CO2 230bar 30l D	Pressure regulator with manometer	394-002910-00030
16A 5POLE/CEE	Mains plug	094-000712-00000
ON AL D13/27	Cap for load sockets	092-003282-00000

10 Appendix

10.1 Parameter overview – setting ranges

Welding data display (3-digit)	Parameters/function	Setting range			
		Standard (ex works)	min.	max.	Unit
MMA (MMA)					
	Main current (AMP)		10 - 300	A	
	Hot start current (AMP%)	120	50 - 200	%	
	Hot start time (sec)	0,5	0,1 - 20,0	s	
	Arcforce correction	0	-8 - 10		
	Arc length restriction	off	off - on		
	Welding current actual value display	off	off - on		
TIG (TIG)					
	Main current AMP		10 - 300	A	
	Arc length restriction	on	off - on		
	Welding current actual value display	off	off - on		

10.2 Searching for a dealer

Sales & service partners
www.ewm-group.com/en/specialist-dealers



"More than 400 EWM sales partners worldwide"